



TECHNICAL CATALOGUE



2 WHEELERS



3 WHEELERS



4 WHEELERS



TRACTORS



LCV, HCV



INDUSTRIES



RAILWAYS



TECHNICAL CATALOGUE



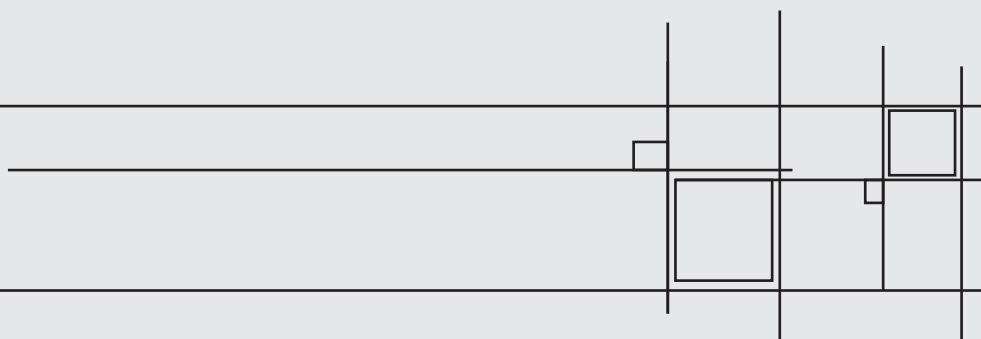

National Engineering Industries Ltd., part of the 150 year old, multi-billion dollar C.K. Birla group manufactures a wide range of Ball & Roller bearings for automotive and railway industry as well as for general industrial applications under the brand name nbc. NEI also manufactures Steel Balls and Axle Boxes, produced at plants located at Jaipur, Newai & Manesar.



NEI, founded in the year 1946 as a pioneer industry in the field of bearing, manufacturing over 1450 different sizes ranging from 6 mm bore to 1300 mm outer diameter and having capability to manufacture bearing upto 2000 mm. diameter.



Bearings are manufactured for every possible application and requirement of modern engineering industry and we continue to develop new sizes, keeping pace with rapid advancement in the Indian & Global engineering industry. NEI's technical collaborations with world's leading conglomerate in the field of bearing technology viz. M/s NTN Corporation of Japan, and M/s AMSTED Rail, USA have given a whole new dimension to the product range and a quality par excellence.

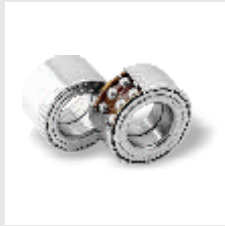

NEI has implemented modern concepts of Total Quality Management (TQM) and being awarded that coveted Deming Application Prize in 2010 and Deming Grand Prize in 2015, NEI is the only bearing company in India to receive these prestigious awards, NEI is also accredited with QS 9000 and TS 16949 certifications.



NEI has also been awarded Association of American Railroads (AAR) for AAR certificate M-1003 for Cartridge Tapered Roller Bearing in February 2005. NEI has been awarded ISO-14001 certificate for its concern & commitment towards a cleaner environment. We at NEI are confident that all users of NEI products will find a new presentation of this technical catalogue useful and informative and you are welcome to consult, NEI for every assistance in selecting right bearing for any application that you have in mind.

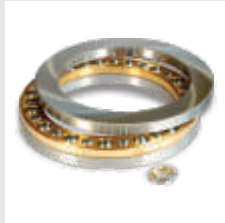

This edition of the NBC Catalogue contains all necessary information and data required for selection of right bearing for specific applications. The data is based on International Standards laid down for the purpose and our manufacturing experience of more than 60 years.

Our catalogue has been revised as per the latest IS/ISO standards for chamfer, dimensions, bearing accuracies, quality symbols and definitions and new sizes being added. For improvement as well as other reasons, the contents of this catalogue are subject to change without prior notice.

This version supersedes all previous ones. Please be informed that the bearings mentioned in this technical catalogue are normally manufactured in normal tolerance class, however, other class bearings can be supplied against specific requirements.

© NEI Ltd. Jaipur 2017

Although care has been taken to ensure the accuracy of the data compiled in this catalogue. NEI does not assume any liability to any company or person for errors or omissions.

MILESTONES

-  1946 Company Established as National Bearing Company (NBC) under Technical Collaboration with Hoffman, U.K.
-  1950 Ball Bearing Production Started
-  1951 Railway Bearing Production Started
-  1957 Company name changed to National Engineering Industries Ltd. (Retaining NBC as Trade Mark)
-  1967 Tapered Roller Bearings Production Started under Technical Collaboration with Federal Mogul Corporation, U.S.A.
-  1971 Established Research & Development Division
-  1971 Established Machine Building Division
-  1975 Large Diameter Special Bearings Production Started
-  1976 Spherical Roller Bearings Production Started with Technical Know how from FAG-SRO
-  1981 Separate Factory for Ball Bearings at Gunsri (Newai)
-  1982 Cartridge Tapered Roller Bearings Production Started in Technical Collaboration with AMSTED Rail - U.S.A.
-  1985 Largest Bearing with Outer Diameter 1.3 Meter & Weight 4.39 Tons produced

1985

Technical Collaboration with NTN Corporation of Japan for Ball, Cylindrical & Spherical Roller Bearings

1990
to 95

Modernization in Three Phases

1995

ISO - 9001 Certificate

1996

Technical Collaboration with M/s Izumi Kinzoku Kogyo Co. Ltd., Japan for Machine Retrofitting/Remanufacturing and overhauling.

1997

Technical Collaboration with NTN Corporation of Japan for Tapered Roller Bearings and Hub Bearings

1999

Implemented 1st Phase of SAP-ERP Solutions.

2000

QS-9000 & ISO-14001 Certification.

2003

TS-16949 Certification.

2005

AAR Certification M-1003 for Cartridge Tapered Roller Bearing.

2006

New Manufacturing facility at IMT Manesar (Haryana)

2007

TPM excellence award Newai plant.

2008

TPM excellence award Jaipur plant.

2010

Deming application prize for Total Quality Management.

2012

ACMA awards for Manufacturing and Technology Excellence

2015

Deming Grand Prize

	PAGE NO.
1. ROLLING BEARING CONSTRUCTION AND CLASSIFICATION	1
1.1 Bearing Classification	
2. BEARING DESIGNATION	5
3. BEARING SELECTION	8
4. LOAD RATING AND LIFE	9
4.1 Basic Dynamic Load Rating and Life	
4.2 NEI Life Enhancement For Rolling Bearing	
4.3 Modified rating life	
4.4 Basic Static Load Rating	
4.5 Life Factors for application	
5. ACCURACY AND TOLERANCES	15
5.1 Dimensional Accuracy	
5.2 Running Accuracy	
5.3 Tolerances for Radial Bearing (except Taper Roller Bearings)	
5.4 Tolerances for Tapered Roller Bearing (Metric Series)	
5.5 Tolerances for Tapered Roller Bearing (Inch Series)	
5.6 Tolerances for Thrust Ball and Roller Bearing (Inch Series)	
5.7 Chamfer Dimensions Limits for Roller Bearing	
5.8 Basic Tapered Bore, Taper 1:12	
6. BEARING INTERNAL CLEARANCE	31
6.1 Internal Clearance Selection	
6.2 Radial Internal Clearance Value	
7. LUBRICATION	40
7.1 Types of Lubrication	
7.2 Methods of Oil Lubrication	
8. SEATINGS, LIMITS AND FITS	48
8.1 Seatings	
8.2 Fits	
8.3 Limits and Fit guidelines	
9. BEARING HANDLING	54
9.1 Mounting	
9.2 Dismounting & Replacement	
9.3 Bearing Cleaning	
9.4 Abutment for Bearing	

10. BEARING FAILURE

63

10.1 Why Bearing Fails

10.2 Bearing Damage & Corrective Measures

11. BEARING TABLES

11.1 Single Row Radial Ball Bearings (Metric series) 68

11.2 Single Row Radial Ball Bearings (Special Bearings) 80

11.3 Single Row Radial Ball Bearings (Inch series) 81

11.4 Single Row Angular Contact Ball Bearings (Metric series) 83

11.5 Single Row Angular Contact Ball Bearings (Inch series) 84

11.6 Double Row Self Aligning Ball Bearings (Metric series) 85

11.7 Double Row Self Aligning Ball Bearings (Inch series) 87

11.8 Double Row Self Aligning Ball Bearings with
Taper Clamping Sleeve and Nut 87

11.9 Special Bearing Races 88

11.10 Double Row Angular Contact Sealed Bearings 89

11.11 Special Bearings 92

11.12 Single Row Cylindrical Roller Bearings (Metric series) 97

11.13 Single Row Cylindrical Roller Bearings (Inch series) 101

11.14 Multi Row Cylindrical Roller Bearings 103

11.15 Special Cylindrical Roller Bearings 103

11.16 Double Row Cylindrical Roller Sealed Unit 106

11.17 Single Row Tapered Roller Bearings (Inch series) 107

11.18 Single Row Tapered Roller Bearings (Metric series) 111

11.19 Double Row Tapered Roller Bearings 117

11.20 Four Row Tapered Roller Bearings 119

11.21 Thrust Bearings 121

11.22 Spherical Roller Bearings 122

11.23 AAR Standard Cartridge Tapered Roller Bearings 128

11.24 Metric Cartridge Tapered Roller Bearings 129

11.25 Units Specified in SI System 130

11.26 Steel Balls 131

11.27 Conversions Tables 132

1. ROLLING BEARING CONSTRUCTION AND CLASSIFICATION

Rolling bearings are generally composed of bearing rings, rolling elements and cages. Several rolling elements are placed between two bearing rings and cages prevent the rolling elements from contact and with such a structure, a smooth rolling action becomes possible.

Rolling bearings are divided into radial bearings and thrust bearings, mainly depending on the applicable load direction. Radial bearing mainly take radial loads. Most types of radial bearings can also take thrust loads. Thrust bearings generally take thrust loads only and not radial loads.

Rolling bearings are largely divided into ball bearings and roller bearings in accordance with the types of rolling elements, Roller bearings are further divided depending on the shape of the roller into cylindrical roller bearings tapered roller bearings, spherical roller bearings and needle roller bearings. Ball bearings are divided into several types, depending on the shape of bearing rings and the contact position between the balls and the raceway.

The cages of rolling bearings are divided into pressed and machined ones with the shapes differing according to the bearings type and conditions of use.

1.1 Bearing Classification

1.1.1 Single Row Radial Ball Bearings

The Single row radial ball bearings accommodate pure radial, pure axial or any combination of radial and axial loads within its capacity. These can operate at very high speeds. For these reasons and its economical price, it is the most widely used bearing.

Owing to high degree of conformity between balls and raceways, the self aligning capability of deep groove ball bearings is small. This fact calls for well aligned bearing mountings.

These bearings can be located endwise in both the directions.

Different variations in the type are as shown below :

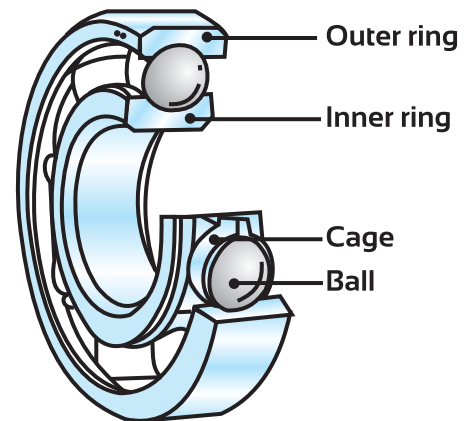

Deep Groove single Row Ball Bearing

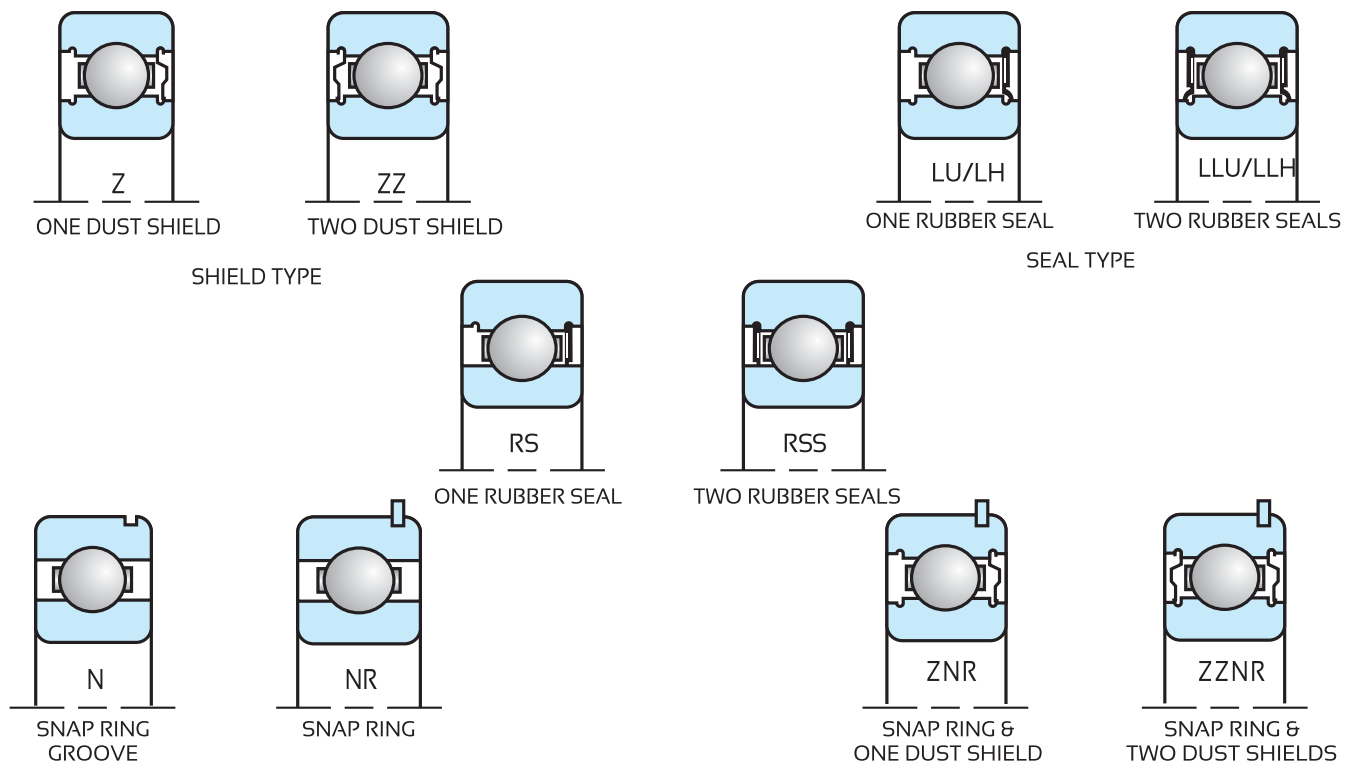

TMB Ball Bearings

TMB ball bearings have the same boundary dimensions as standard deep groove ball bearings, but have undergone a special heat treatment that considerably extends wear life. These bearings were especially effective in countering reduced wear life due to the effects of infiltration of dust and other foreign matter.

- ❖ TMB ball bearings' special characteristics are identical to standard ball bearings at rated loads, but with a bearing characterization factor of $a_2 = 2.2$
- ❖ TMB 62 series bearings can be used in place of standard 63 series bearings enabling lighter weight, more compact designs.

For dimensional specifications and other detailed information about TMB ball bearings, contact NEI Technical Cell.

1.1.2 Single Row Radial Ball Bearing with Tapered Bore

The single row radial ball bearings with tapered bore are identical to single row radial ball bearings except that these have tapered bore which is used for easier mounting and for the adjustment of radial clearance.

Dimensions of tapered bore diameter refer to small bore.

1.1.3 Single Row Angular Contact Ball Bearing

The single row angular contact ball bearings have higher axial load capacity than the single row radial ball bearings. The radial load must always be less than axial load.

The bearings can carry axial load in one direction only and should be adjusted against another bearing, if axial load is coming from both the directions.

Each bearing can be located endwise in one direction only.

1.1.4 Single Row Externally Aligning Ball Bearing

The single row externally aligning ball bearings are used where accurate alignment can not be guaranteed between bearing positions. It can take radial loads. Axial loads can also be accommodated.

The shell housing must not be made an interference fit on their outside diameter. If an interference fit is used, the shell housing may contract and prevent alignment.

These bearings can be located endwise in both the directions.

1.1.5 Double Row Self Aligning Ball Bearing

The double row self aligning ball bearings have the common outer spherical race for both the rows. This feature gives the bearings self aligning properties. The bearings have the same external dimensions as their equivalent single row radial ball bearings. They can take radial loads and very light axial loads. They can be located endwise in both the directions.

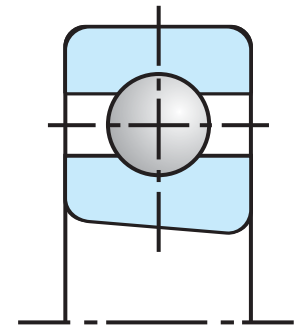

SINGLE ROW RADIAL BALL BEARING WITH TAPER BORE

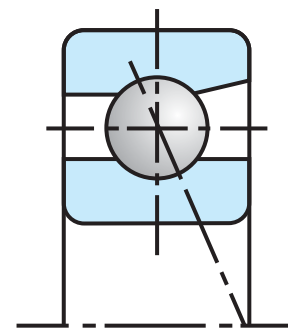

SINGLE ROW ANGULAR CONTACT BALL BEARING

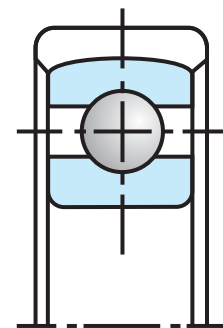

SINGLE ROW EXTERNALLY ALIGNING BALL BEARING

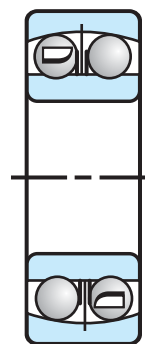

CYLINDRICAL BORE

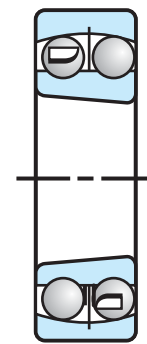

TAPERED BORE 1:12

Double Row Self Aligning Ball Bearing

1.1.6 Double Row Self-Aligning Ball Bearing with Tapered Clamping Sleeve and Nut

The double row self-aligning ball bearings with tapered clamping sleeve and nut are identical to double row self-aligning ball bearing except that these have a tapered bore, which is used for easier mounting and also a clamping sleeve and nut to clamp the bearings on the shaft. The tapered bore is also used for the adjustment of radial clearance.

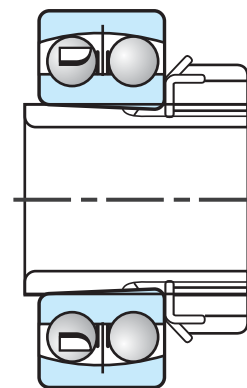

Double Row Self-Aligning Ball Bearing with Tapered Clamping Sleeve and Nut

1.1.7 Thrust Ball Bearing

The thrust ball bearings are used for high axial loads at low speeds. These can not operate at high speed as it will give rise to centrifugal or radial forces which can not be taken by the bearings.

They can be located endwise in one direction only.

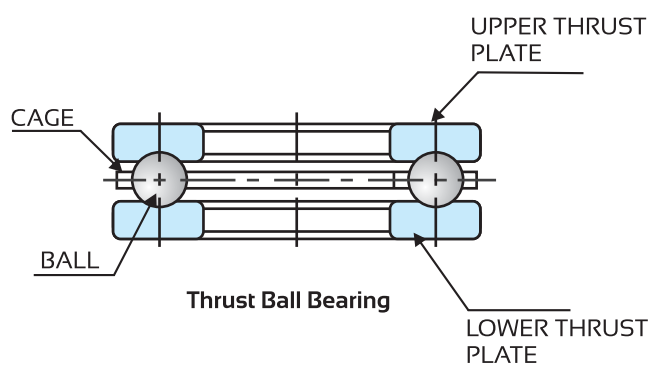

1.1.8 Cylindrical Roller Bearing

The cylindrical roller bearings have greater radial load capacity than ball bearings of same external dimensions and are particularly suitable for arduous duties. The bearing features a modified line contact between rollers and raceways to eliminate edge stressing. These bearings have a high radial load capacity and are suitable for high speeds. Due to detachable design character they have advantage of mounting inner ring and outer ring separately.

The direction of axial load which a bearing can take depending upon the geometry of the bearing. Many variations available are shown below :

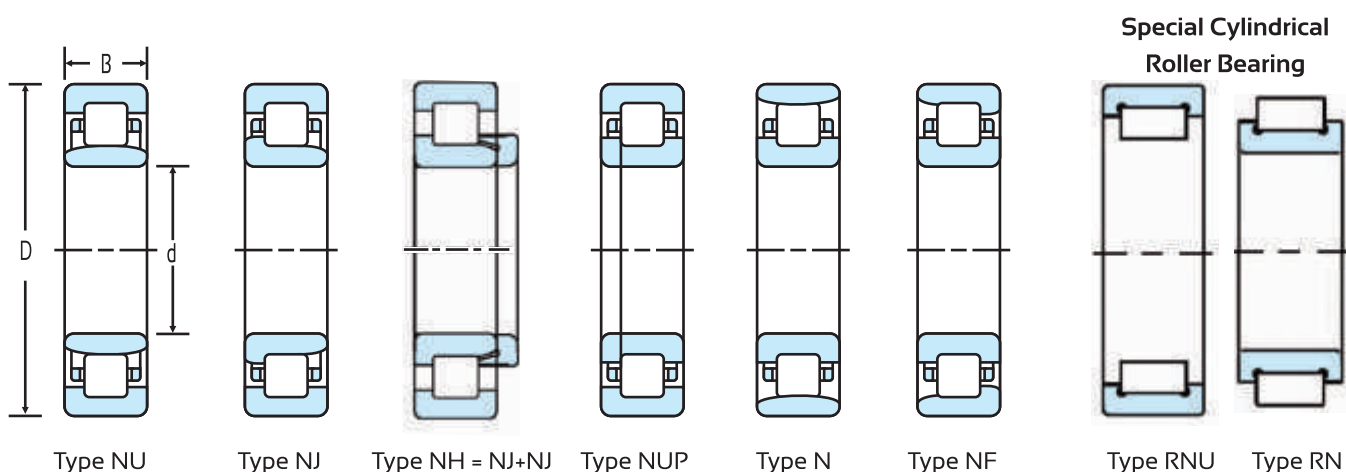

1.1.9 Tapered Roller Bearing

Tapered roller bearings are designed in such a way that vertices of the cone for each roller and those for the inner and outer raceways coincide on the bearing axis or extensions of the raceways and rollers converge at a common point on the axis of rotation. This results in true rolling motion of the rollers on the raceways at every point along the rollers.

The tapered roller bearings support radial loads and axial loads from one direction only. The line contact between rollers and raceways provides the bearings with a high load carrying capacity. Steep angle tapered roller bearing with exceptionally steep cone angle enables the bearings to take heavier axial load.

The bearings are of separable type, enabling separate mounting of cups and cones.

Since the tapered roller bearings can absorb thrust loads in one direction only, these bearings should generally be installed as opposed mountings. The correct amount of radial and axial clearance is obtained by adjusting the two bearings against each other.

Besides, double row and four row tapered roller bearings are also widely used for heavy loads such as rolling mills.

A single row tapered roller bearing can be located endwise in one direction only.

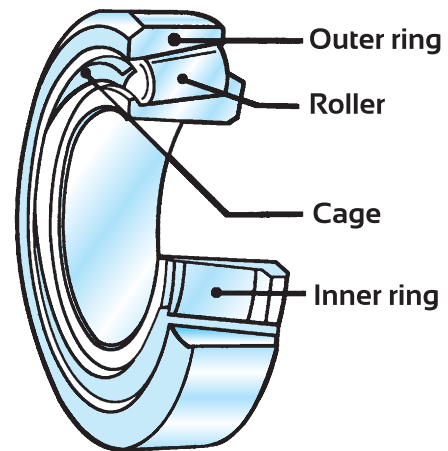
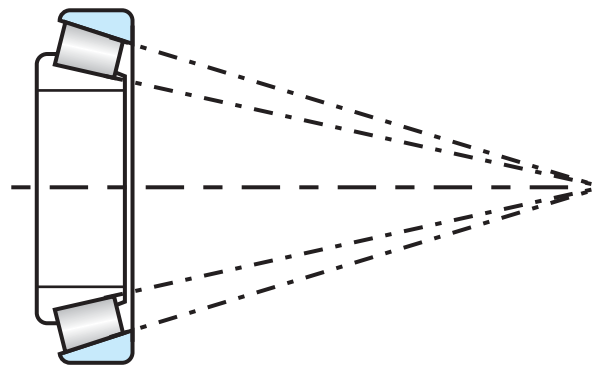

Tapered Roller Bearing

1.1.10 Spherical Roller Bearing

Spherical roller bearings are particularly suitable for carrying heavy loads. They are usually of the double row design, both of the rows of the rollers having common spherical raceways in the outer ring. This feature of this bearing has great practical importance in those cases where it is difficult to obtain exact parallelism between the shaft and housing both axes. So these bearings are suitable where misalignment can arise from mounting errors or from deflection of the shaft.

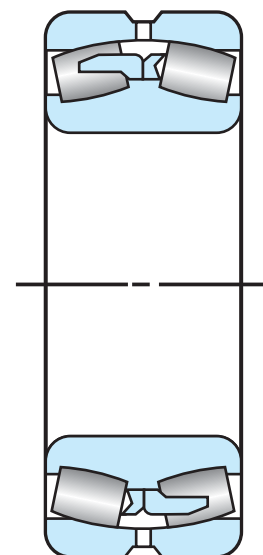

Spherical Roller Bearing

2. BEARING DESIGNATION

Rolling bearing part numbers indicate bearing type, dimensions, tolerances, internal construction & other related specifications. The first letter (digit) indicates the bearing type. The second digit indicates the width (or height) series & the third indicates the diameter series. The last two digits indicate the bore diameter by multiplying the last two digit by five for bearing having bore diameter original 40 mm & above. This method is applicable for metric series bearing only.

Example

6207 Z C3

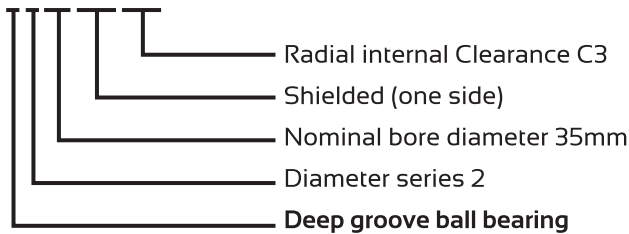

22328

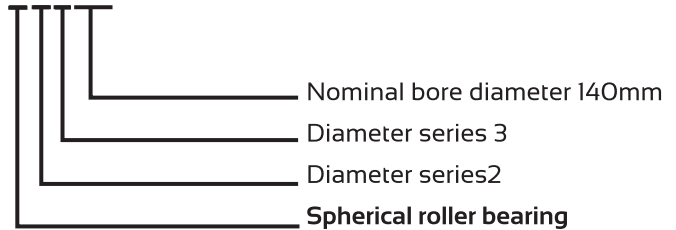

7212C

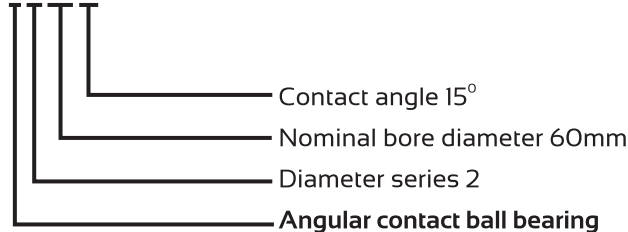

NU330C3

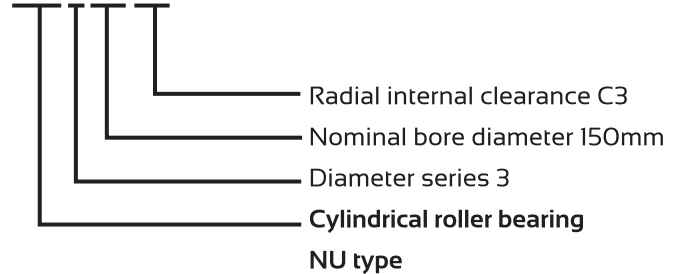

30204

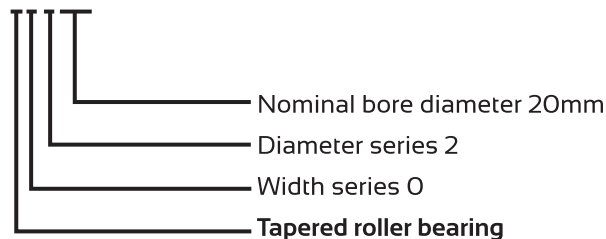

1206K

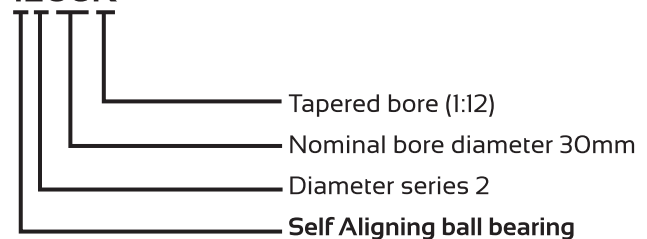

Table 2.1

Bearing Nomenclature

Prefix code Code- Interpretation	Bearing basic number				Bore diameter code	Interpretation Bore dia., mm	Suffix code Internal design modification code
	Series code	Interpretation		Dia. Series			
		Bearing type	Dimension series code Width series				
<i>TS1</i> - Bearing with special heat treatment for operating temp. up to 130°C	68			8	/0.6 /1.5 /xx	0.6 1.5 xx	A - Internal design modification from A onward
<i>TS2</i> - Bearing with special heat treatment for operating temp. up to 160°C	69	6- Deep groove ball bearings		9			
	60		-	0			
	62			2			
	63			3			
<i>TS3</i> - Bearing with special heat treatment for operating temp. up to 200°C					00 01 02 03	10 12 15 17	C - contact angle 15°, angular contact ball bearing C - Contact angle 17° -24°, Tapered roller bearings
<i>TS4</i> - Bearing with special heat treatment for operating temp. up to 250°C	78	7- Angular contact ball bearings		8			
<i>TM</i> - Long life special heat-treated bearing (one ring)	79			9			
	70		-	0			
	72			2			
<i>TMB</i> - Long life special heat-treated bearing (both the rings)	73		3		04 05 . . 92 96	dia. code multiplied by 5 gives the bore dia. value in mm	D - Contact angle 24° -32°, Tapered roller bearings E - Cylindrical/Spherical roller bearing with optimized internal geometry for increased load rating E - Tapered roller bearing with special crown on raceways
<i>AST</i> - Bearing with one of the components treated in carbo nitriding		1,2- Self aligning ball bearings		2			
<i>ASTB</i> - Bearing with both the components treated in carbo nitriding	12			3			
	13		-	2			
	22			2			
<i>TMS2</i> - Bearing with special heat treatment (TMB + TS2)	23		3		. . 92 96	. . 2,360 2,500	X(n) - Special feature (Inner ring or outer ring) e.g. X1, X2 SPL - Optimized internal design for low torque
<i>TH2</i> - Bearing with high temp. tempering on both the rings		Cylindrical roller bearings		4			
<i>TMH2</i> - Bearing with special heat treatment (TMB + TH2)				4			
				4			
<i>CR</i> - Creep resistance bearing with single side O-ring on outer race	<i>NU10</i>			0		/500 /530 /560 . . /2,360 /2,500	500 530 560 . . 2,360 2,500
	<i>NU2</i>		2				
	<i>NU22</i>	NU, NJ, NH, NUP, N, NF,	2	2			
	<i>NU3</i>	NNU, NN,	-	3			
	<i>NU23</i>	RNU, RN-	2	3	. . /2,360 /2,500	. . 2,360 2,500	C - Spherical roller bearing with symmetrical rollers, flangeless inner ring, a non-integral guide ring between the two rows of rollers centred on the inner ring and one pressed steel window-type cage for each roller row CA - Spherical roller bearing with one-piece machined brass cage (double pronged), symmetrical rollers and retaining ribs CC - Similar to 'C' configuration but with enhanced roller & raceways surface finish V - Full complementary cylindrical roller bearing
	<i>NU4</i>	Cylindrical roller bearings	-	4			
	<i>NNU49</i>		4	9			
	<i>NN30</i>		3	0			
<i>L</i> - Light series (taper roller bearing-inch series)					. . /2,360 /2,500	. . 2,360 2,500	C - Spherical roller bearing with symmetrical rollers, flangeless inner ring, a non-integral guide ring between the two rows of rollers centred on the inner ring and one pressed steel window-type cage for each roller row CA - Spherical roller bearing with one-piece machined brass cage (double pronged), symmetrical rollers and retaining ribs CC - Similar to 'C' configuration but with enhanced roller & raceways surface finish V - Full complementary cylindrical roller bearing
<i>LM</i> - Light medium series (taper roller bearing- inch series)							
<i>HM</i> - Heavy medium series (taper roller bearing-inch series)							
<i>M</i> - Medium series (taper roller bearing- inch series)							
<i>H</i> - Heavy series (non-interchangeable with other cones & cups- for taper roller bearing- inch series)	302		0	2	. . /2,360 /2,500	. . 2,360 2,500	C - Spherical roller bearing with symmetrical rollers, flangeless inner ring, a non-integral guide ring between the two rows of rollers centred on the inner ring and one pressed steel window-type cage for each roller row CA - Spherical roller bearing with one-piece machined brass cage (double pronged), symmetrical rollers and retaining ribs CC - Similar to 'C' configuration but with enhanced roller & raceways surface finish V - Full complementary cylindrical roller bearing
	303		0	3			
	313		1	3			
	320		2	0			
<i>HH</i> - Heavy heavy series (non-interchangeable with other cones & cups for taper roller bearing-inch series)	322	3- Tapered roller bearings	2	2	. . /2,360 /2,500	. . 2,360 2,500	C - Spherical roller bearing with symmetrical rollers, flangeless inner ring, a non-integral guide ring between the two rows of rollers centred on the inner ring and one pressed steel window-type cage for each roller row CA - Spherical roller bearing with one-piece machined brass cage (double pronged), symmetrical rollers and retaining ribs CC - Similar to 'C' configuration but with enhanced roller & raceways surface finish V - Full complementary cylindrical roller bearing
	323		2	3			
	329		2	9			
	330		3	0			
<i>N</i> - Taper bearing having non-standard boundary dimensions	331		3	1	. . /2,360 /2,500	. . 2,360 2,500	C - Spherical roller bearing with symmetrical rollers, flangeless inner ring, a non-integral guide ring between the two rows of rollers centred on the inner ring and one pressed steel window-type cage for each roller row CA - Spherical roller bearing with one-piece machined brass cage (double pronged), symmetrical rollers and retaining ribs CC - Similar to 'C' configuration but with enhanced roller & raceways surface finish V - Full complementary cylindrical roller bearing
	330		3	0			
	331		3	1			
	332		3	2			
<i>N</i> - Cylindrical bearing having non-standard boundary dimensions					. . /2,360 /2,500	. . 2,360 2,500	C - Spherical roller bearing with symmetrical rollers, flangeless inner ring, a non-integral guide ring between the two rows of rollers centred on the inner ring and one pressed steel window-type cage for each roller row CA - Spherical roller bearing with one-piece machined brass cage (double pronged), symmetrical rollers and retaining ribs CC - Similar to 'C' configuration but with enhanced roller & raceways surface finish V - Full complementary cylindrical roller bearing
<i>NA</i> - Cones mated with double cup to form double row non-adjustable bearing (non-interchangeable with other cones & cups)	239		3	9	. . /2,360 /2,500	. . 2,360 2,500	C - Spherical roller bearing with symmetrical rollers, flangeless inner ring, a non-integral guide ring between the two rows of rollers centred on the inner ring and one pressed steel window-type cage for each roller row CA - Spherical roller bearing with one-piece machined brass cage (double pronged), symmetrical rollers and retaining ribs CC - Similar to 'C' configuration but with enhanced roller & raceways surface finish V - Full complementary cylindrical roller bearing
	230		3	0			
	240		4	0			
	231		3	1			
<i>X</i> - Inch series tapered roller bearing converted into metric series	241	2- Spherical roller bearings	4	1	. . /2,360 /2,500	. . 2,360 2,500	C - Spherical roller bearing with symmetrical rollers, flangeless inner ring, a non-integral guide ring between the two rows of rollers centred on the inner ring and one pressed steel window-type cage for each roller row CA - Spherical roller bearing with one-piece machined brass cage (double pronged), symmetrical rollers and retaining ribs CC - Similar to 'C' configuration but with enhanced roller & raceways surface finish V - Full complementary cylindrical roller bearing
	222		2	2			
	232		3	2			
	213		1	3			
<i>T</i> - tapered roller thrust bearing	213		1	3	. . /2,360 /2,500	. . 2,360 2,500	C - Spherical roller bearing with symmetrical rollers, flangeless inner ring, a non-integral guide ring between the two rows of rollers centred on the inner ring and one pressed steel window-type cage for each roller row CA - Spherical roller bearing with one-piece machined brass cage (double pronged), symmetrical rollers and retaining ribs CC - Similar to 'C' configuration but with enhanced roller & raceways surface finish V - Full complementary cylindrical roller bearing
	223		2	3			
<i>J</i> - Inch series bearing with metric designation					. . /2,360 /2,500	. . 2,360 2,500	C - Spherical roller bearing with symmetrical rollers, flangeless inner ring, a non-integral guide ring between the two rows of rollers centred on the inner ring and one pressed steel window-type cage for each roller row CA - Spherical roller bearing with one-piece machined brass cage (double pronged), symmetrical rollers and retaining ribs CC - Similar to 'C' configuration but with enhanced roller & raceways surface finish V - Full complementary cylindrical roller bearing
<i>SP</i> - standard bearing with deviations in OD/width from original bearing number					. . /2,360 /2,500	. . 2,360 2,500	C - Spherical roller bearing with symmetrical rollers, flangeless inner ring, a non-integral guide ring between the two rows of rollers centred on the inner ring and one pressed steel window-type cage for each roller row CA - Spherical roller bearing with one-piece machined brass cage (double pronged), symmetrical rollers and retaining ribs CC - Similar to 'C' configuration but with enhanced roller & raceways surface finish V - Full complementary cylindrical roller bearing
<i>QJ</i> - Four point angular contact ball bearing	292	2- Spherical roller thrust bearings	9	2	. . /2,360 /2,500	. . 2,360 2,500	C - Spherical roller bearing with symmetrical rollers, flangeless inner ring, a non-integral guide ring between the two rows of rollers centred on the inner ring and one pressed steel window-type cage for each roller row CA - Spherical roller bearing with one-piece machined brass cage (double pronged), symmetrical rollers and retaining ribs CC - Similar to 'C' configuration but with enhanced roller & raceways surface finish V - Full complementary cylindrical roller bearing
	293		9	3			
	294		9	4			
<i>BB,LS,MS</i> - Ball bearing with non-standard boundary dimensions					. . /2,360 /2,500	. . 2,360 2,500	C - Spherical roller bearing with symmetrical rollers, flangeless inner ring, a non-integral guide ring between the two rows of rollers centred on the inner ring and one pressed steel window-type cage for each roller row CA - Spherical roller bearing with one-piece machined brass cage (double pronged), symmetrical rollers and retaining ribs CC - Similar to 'C' configuration but with enhanced roller & raceways surface finish V - Full complementary cylindrical roller bearing

Suffix code							
External design modification code	Bearing arrangement type code	Cage type code	Seal/Shield type code	Internal clearance code	Tolerance class code	Lubricant type code	Noise class code
<p>D- Double row outer ring or inner ring</p> <p>K- Tapered bore, 1/12 taper on dia.</p> <p>K30- Tapered bore, 1/30 taper on dia.</p> <p>N- Locating snap ring groove on outer ring</p> <p>NR- Locating snap ring on outer ring</p> <p>G- Helical groove in bearing bore (Multi-row tapered/ cylindrical roller bearing components)</p> <p>RO- Modified profile on outer ring surface</p> <p>RI- Modified profile on inner ring surface</p> <p>W- Lubrication grooves / slots in the side faces of the bearing rings (Multi-row tapered roller bearings)</p> <p>W33- Bearing with annular groove and three lubrication holes in the outer ring (Spherical roller bearing)</p> <p>W33X- Similar to "W33" configuration but with six lubrication holes</p>	<p>DB- Two single-row deep groove /angular contact ball/ tapered roller bearing matched for mounting in a back-to-back arrangement</p> <p>DF- Two single-row deep groove/ angular contact ball/ tapered roller bearing matched for mounting in a face-to-face arrangement</p> <p>DT- Two single-row deep groove/ angular contact ball/ tapered roller bearing matched for mounting in a tandem arrangement</p>	<p>J- Pressed steel cage</p> <p>T2X- Polyamide cage</p> <p>G2- Pin type steel cage</p> <p>MA- Machined brass cage, outer ring guided (spherical / cylindrical roller bearing)</p> <p>MB- Machined brass cage, inner ring guided (spherical / cylindrical roller bearing)</p>	<p>L,R- Synthetic rubber seal, contact type, on one side</p> <p>LL,RR- Synthetic rubber seal, contact type, on both side</p> <p>LB- Synthetic rubber seal, non-contact type, on one side</p> <p>LLB- Synthetic rubber seal, non-contact type, on both side</p> <p>LC- Synthetic rubber seal with guard steel plate, contact type, double lip, on one side</p> <p>LLC- Synthetic rubber seal with guard steel plate, contact type, double lip, on both side</p> <p>LH- Low friction synthetic rubber seal, contact type, double lip, on one side</p> <p>LLH- Low friction synthetic rubber seal, contact type, double lip, on both side</p> <p>LU- Synthetic rubber seal, contact type, double lip, on one side</p> <p>LLU- Synthetic rubber seal, contact type, double lip, on both side</p> <p>LLF- Synthetic rubber seal, non-contact type, on both sides</p> <p>LV- Low friction synthetic rubber seal, contact type, triple lip, on one side</p> <p>LLV- Low friction synthetic rubber seal, contact type, triple lip, on both side</p> <p>LUA- Acrylic rubber seal (Contact type), single side with Seal groove on Inner race</p> <p>LLUA- Acrylic rubber seal (Contact type), both side with Seal groove on Inner race</p> <p>LUAI- Fluorine rubber seal, LU type, on one side, for high temperature upto 200° C</p> <p>LLUAI- Fluorine rubber seal, LU type, on both side, for high temperature upto 200° C</p> <p>LUA2- Silicone rubber seal, LU type, on one side, for extreme temperature -100 to +200° C</p> <p>LLUA2- Silicone rubber seal, LU type, on both side, for extreme temp. -100 to +200° C</p> <p>RS- NBR rubber seal (Contact type), single side with no Seal groove on Inner race</p> <p>RSS- NBR rubber seal (Contact type), on both with no Seal groove on Inner race</p> <p>RSZ- RS type rubber seal on one side, Z type pressed steel shield</p> <p>Z- Metallic shield, single side</p> <p>ZZ- Metallic shield, double side</p> <p>ZA- Removable pressed steel shield, on one side</p> <p>ZZA- Removable pressed steel shield, on both side</p>	<p>C2- Clearance less than Normal</p> <p>CN- Normal clearance</p> <p>C3- Clearance greater than normal</p> <p>C4- Clearance greater than C3</p> <p>C5- Clearance greater than C4</p> <p>CNL- Radial clearance range on lower side of CN</p> <p>C3L- Radial clearance range on lower side of C3</p> <p>C4L- Radial clearance range on lower side of C4</p> <p>C5L- Radial clearance range on lower side of C5</p> <p>CNH- Radial clearance range on higher side of CN</p> <p>C3H- Radial clearance range on higher side of C3</p> <p>C4H- Radial clearance range on higher side of C4</p> <p>C5H- Radial clearance range on higher side of C5</p> <p>CS(n)- Special radial clearance as per customer requirement</p>	<p>P0- Normal Tolerance class (Class 0, 6X) specified by IS/ISO/JIS</p> <p>P6- Tolerance class 6 specified by IS/ISO/JIS</p> <p>P5- Tolerance class 5 specified by IS/ISO/JIS</p> <p>P4- Tolerance class 4 specified by IS/ISO/JIS</p> <p>P2- Tolerance class 2 specified by IS/ISO/JIS</p> <p>PX(n)- Special tolerance class as per customer requirement</p>	<p>2A- Shell Alvania-2 grease (Shell Alvania RL2)</p> <p>3A- Shell Gadus S2-V100 3 (Shell Alvania RL3)</p> <p>R2- Shell Gadus S3-V220C 2 (Shell Retinex LX2)</p> <p>2E- Unirex N3 grease</p> <p>E5- NTN L417</p> <p>6B- Pyronoc N6B</p> <p>6C- Pyronoc N6C</p> <p>NS- Nigace WRS</p> <p>AB2- Shell Albida 2</p> <p>5C- Chevron SRI</p> <p>KA- KLUBER ASONIC HQ 72-102</p> <p>KS- Kluber Synth BEP 72-82</p>	<p>EM- Noise level class for electric motor application</p> <p>EML- Low Noise bearings</p>

3. BEARING SELECTION

The following procedure gives the steps to be followed when bearings are selected from the information contained in this catalogue. It will be found satisfactory for most applications, but to be sure, please consult the NEI Advisory Service.

1.
 - a. Determine the speed of the bearing.
 - b. Calculate the loads on the bearing.
 2. Establish if accurate alignment can be obtained between the bearing seating. If it can not, then bearings that accommodate misalignment should be selected.
 3. If the bearing is to rotate under load, decide the life required, calculate the required 'C' value, and then select suitable bearing that have comparable 'C' value.
 4. Check if the bearing is suitable for the speed and decide if grease or oil is to be the lubricant.
 5. Select a suitable bearing arrangement if this is not already known. Make sure that this arrangement is suitable to seating fits.
 6. Finally
 - a. decide whether 'Standard' or 'Extra Precision' limit of accuracy is required.
 - b. select the most suitable range of diametric clearance.
 - c. choose the abutment diameters.
 - d. choose suitable closures.
 - e. issue mounting and handling instructions for the bearings if necessary.
1. Provide a drawing or sketch showing layout of the parts involved and position in which the bearings are to be fitted, giving size of shaft and any dimensions limiting the space available.
 2. Include a brief description of the mechanism if this is not clear from the drawing.
 3. Give the speed and sufficient information, so that load on each bearing can be calculated accurately.
 4. Indicate any unusual features such as the possibility of shock or vibration, unbalanced load, high temperature, or the presence of dirt, moisture or fumes.
 5. Give the bearing life requirements and indicate whether the duty is continuous for 24 hrs. a day, or only intermittent. If intermittent, give periods of running and standing.
 6. If the working conditions vary considerably, give the normal duty and also the peak conditions with the frequency and duration of peaks.
 7. Say whether oil or grease lubrication is to be used.
 8. Say whether the bearings can be lined up accurately or whether bearings with an aligning feature are required.

Please consult NEI

- i) If bearings are required in corrosion-resisting or in other special materials.
- ii) If two bearings are mounted close together, special pairing of the two bearings may be necessary to ensure that they share the load.
- iii) If the speed and temperature conditions are not provided for the information contained in this catalogue.

BEARING SELECTION BY NEI ADVISORY SERVICE

Our Engineers will be pleased to recommend the most suitable bearing and best method of mounting for any specified conditions. If you wish to use this service you should send all information relevant to your purpose on the following basis.

4. LOAD RATING AND LIFE

4.1 Basic Dynamic Load Rating and Life

Even in bearings operating under normal conditions the surface of the raceways and rolling elements are constantly being subjected to repeated compressive stresses which cause flaking of these surfaces to occur. This flaking is due to material fatigue and will eventually cause the bearing to fail.

The effective life of a bearing is usually defined in terms of the total numbers of revolutions a bearing can undergo before flaking of either the raceway surface or the rolling elements surfaces occurs.

When a group of apparently identical bearings operate under identical load conditions, the life of individual bearings show a considerable dispersion. Therefore, a statistical definition of the life is applied for the calculation of the bearing life. When selecting a bearing, it is not correct to regard the average life of all bearings as the criterion of life: It is more practical to adopt the life that the majority of bearing will attain or exceed.

For this reason the basic rating life of a group of bearings is defined as the number of revolutions (or hours at some given constant speed) that 90% of the group of bearings will complete or exceed before the first evidence of fatigue develops.

The basic dynamic load is defined as the constant stationary load which a group of bearings with stationary outer ring can endure for a rating life of one million revolutions of the inner ring. It refers to pure radial load for radial bearings and to pure axial load for thrust bearings.

The relationship among the bearing basic dynamic load rating, the bearing load and the basic rating life, is given by the following formula, based on ISO 281

$$L_{10} = \left(\frac{C}{P}\right)^p$$

Where

- L_{10} = Basic rating life in millions revolutions
- C = Basic dynamic load rating, in Newton
- P = Equivalent dynamic load, in Newton
- p = exponent for the life formula
3 for ball bearings
10/3 for roller bearings

In many cases it is convenient to express the basic rating life in terms of operating hours rather than the number of revolutions, using the following procedure:

Where

$$L_{10h} = 500 (f_h)^p$$

$$f_h = f_n \left(\frac{C}{P}\right)$$

$$f_n = \left(\frac{33.3}{n}\right)^{1/p}$$

Where

- L_{10h} = basis rating in hours of operation
- f_h = life factor
- f_n = speed factor
- n = operating speed, rev./min

The above formula may also be expressed as :

$$L_{10h} = \frac{10^6}{60n} \left(\frac{C}{P}\right)^p$$

The basic rating life can also be expressed in terms of kilometers for wheel bearings as shown in formula below:

$$L_{105} = \frac{\pi D}{1000} \times L_{10}$$

- Where D = Wheel diameter in mm
- L_{105} = Basic rating life in kms.

The value of f_n and the rating life for ball and roller bearing can be found by means of the diagrams given on page no. 8.

4.1.1 Adjusted rating life (L_{na})

The basic life rating (90% reliability factor) can be calculated through the formula mentioned above. However, in some applications a bearing life factor of over 90% reliability may be required to meet these requirements, bearing life can be lengthened by the use of specially improved bearing material or special construction technique. Moreover according to elastohydrodynamic lubrication theory, it is clear that the bearing operating conditions (lubrication, temperature, speed, etc.) all exert an effect on bearing life. All these adjustment factors are taken into consideration while calculating bearing life and using the life, adjustment factor as prescribed in ISO 281:1990 the adjusted rating life is

$$L_{na} = a_1 \cdot a_2 \cdot a_3 \cdot (L_{10})^p$$

Where,

- L_{na} : Adjustment life rating in millions of revolutions (10^6) adjusted for reliability, material and operating conditions
- a_1 : Reliability adjustment factor
- a_2 : Material/construction adjustment factor
- a_3 : Operating condition adjustment factor

4.1.1.1 Life adjustment factor for reliability a_1

The values for the reliability adjustment factor a_1 (for a reliability factor higher than 90%) can be found from table given below :-

Reliability adjustment factor values

Reliability	L_n	Reliability factor a_1
90	L_{10}	1.00
95	L_5	0.62
96	L_4	0.53
97	L_3	0.44
98	L_2	0.33
99	L_1	0.21

Formula for factor a_1
 $a_1 = 4.48 [\ln(100/R)]^{2/3}$
 R = Reliability
 L_n = Log Factor (Base 'e')

4.1.1.2 Life adjustment factor for material construction a_2

The value for the basic dynamic load rating given in the bearing dimension tables are for bearings constructed from NEI's continued efforts at improving the quality and life of its bearings.

Accordingly, $a_2 = 1$ is used for the adjustment factor in the formula. For bearings constructed of specially improved materials or with special manufacturing methods, the life adjustment factor a_2 in life can have a value greater than one.

When high carbon chromium steel bearings, which have undergone only normal heat treatment, are operated for long periods of time at temperatures in excess of 120°C considerable dimensional deformation may take place. For this reason, there are special high temperature bearings which have been heat treated for dimensional stability. This special treatment allows the bearing to operate at its maximum operational temperature without the occurrence of dimensional changes. However, these dimensionally stabilized bearings, designated with a 'TS' prefix have a reduced hardness with a consequent decrease in bearing life. The adjusted life factor values used in life formula for such heat-stabilized bearing can be found in Table given below

Code	Max. operating temperature °C	Adjustment factor a_2
TS2	160	0.87
TS3	200	0.68
TS4	250	0.30

4.1.1.3 Life adjustment factor a_3 for operating conditions

The operating conditions life adjustment factor a_3 is used to adjust for conditions such as lubrication, operating temperature, and other operation factors which have an effect on bearing life.

Generally speaking when lubricating conditions are satisfactory the a_3 factor has a value of one, and when lubricating conditions are exceptionally favourable, and all other operating conditions are normal a_3 can have a value greater than one.

However, when lubricating conditions are particularly unfavorable and oil film formation on the contact surfaces of the raceway and rolling elements is insufficient, the value of a_3 becomes less than one. This insufficient oil film formation can be caused, for example, by the lubricating oil viscosity being too low for the operating temperature (below 13 mm²/s for ball bearing and below 20mm²/s for roller bearings); or by exceptionally low rotational speed [n (r/min) x d_p (mm) less than 10,000]. For bearings used under special operating conditions, please consult NEI.

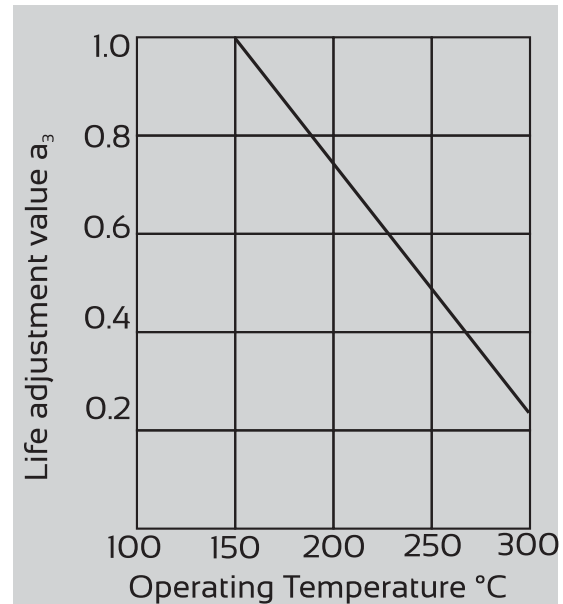

Life adjustment value for operating temperature °C As the operating temperature of the bearing increases, the hardness of the bearing material decreases. Thus, the bearing life correspondingly decreases. The operating temperature adjustment values are shown in above figure.

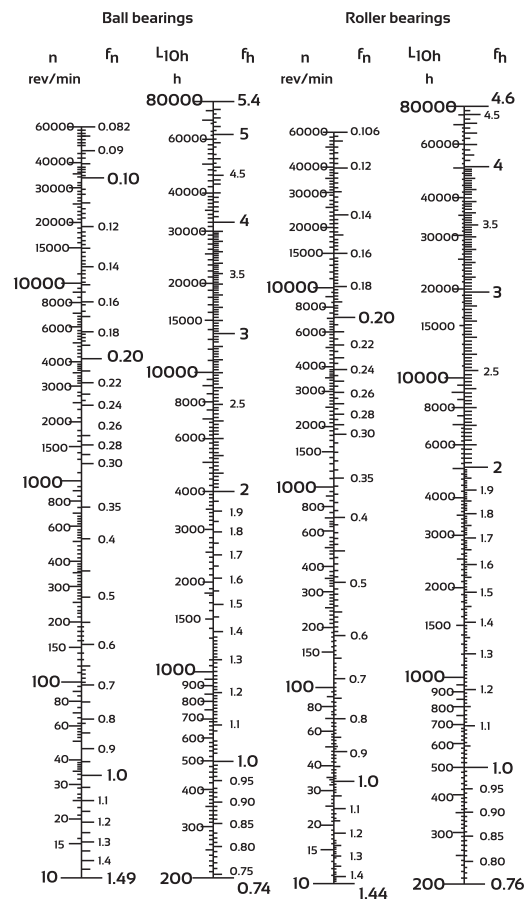

Fig. Diagram for basic rating life

4.2 NEI Life Enhancement For Rolling Bearing

In addition to design parameters the service life of rolling bearings can be greatly enhanced by material and heat treatment processes, thereby influencing the grain structure of the steel with surface modifications. A special heat treatment is given to the bearings there by effectively, alter the microstructure which in turns improves the yield strength and rolling contact fatigue properties. The special heat treatment process leverages the combined advantage of having modified surface and core microstructure to significantly extend the bearing life. To prove the effectiveness of bearing made from special manufacturing process extensive laboratory and field tests were carried out. The positive results from the test helped in deciding the life multiplication factor for NEI bearings. However the selection of the special treatments depends on the application and type of bearing. Consult NEI representative for additional information and support. Please refer the table below for special treatment factors

Special Treatment	Life Multiplication Factor
TS2	1
4T	1.4
TMB	2.2
TM	2
AST	2
ASTB	3
MLB	4

4.3 Modified rating life (L_{nm})

The rating life modified for 90% or other reliability considering fatigue load, and/or special bearing properties, and/or contaminated lubricant and other non-conventional operating conditions.

The modified rating life is calculated according to the formula prescribed in ISO281:2007.

$$L_{nm} = a_1 \cdot a_{ISO} \cdot L_{10}$$

L_{nm} modified rating life [10^6 revolutions]

a_1 reliability adjustment factor (refer to 4.1.1.1 on page 9)

a_{ISO} life modification factor for operating conditions

This method evaluates the bearing life by using the life modification factor (a_{ISO}) and the life adjustment factor for reliability (a_1), that are dependent on the type, size and internal geometry of the bearing, the manufacturing quality, the fatigue limit of the raceway material, lubrication method, type of lubricant, viscosity, additives, cleanliness and filtration, operating temperature and bearing speed. The life modification factor (a_{ISO}) can be estimated from graphs and equations given in ISO281:2007 standard.

The life modification factor (a_{ISO}) is a function of

$$a_{ISO} = f \left[\frac{e_c C_u}{P}, k \right]$$

Where

e_c Contamination factor

C_u Fatigue load limit in newtons

K Viscosity ratio(κ)

P Dynamic Equivalent load in newtons

4.3.1 Fatigue load limit (C_u)

The fatigue load limit (C_u) is calculated according to ISO 281 :2007 and is defined as the load below which, under laboratory conditions, no fatigue occurs in the material or the load at which the fatigue stress limit just reached the most heavily loaded raceway contact. This load depends on the pitch diameter of the rolling elements and the basic static load rating. The formula for calculation for fatigue load limit (C_u) is given below:

For Ball bearing:

$$C_u = \frac{C_o}{22} \text{ for bearings with } D_{pw} \leq 100 \text{ mm}$$

$$C_u = \frac{C_o}{22} \left(\frac{100}{D_{pw}} \right)^{0.5} \text{ for bearings with } D_{pw} > 100 \text{ mm}$$

For Roller bearing :

$$C_u = \frac{C_o}{8.2} \text{ for bearings with } D_{pw} \leq 100 \text{ mm}$$

$$C_u = \frac{C_o}{8.2} \left(\frac{100}{D_{pw}} \right)^{0.3} \text{ for bearings with } D_{pw} > 100 \text{ mm}$$

where

C_o is the basic static load rating in newton

D_{pw} is the pitch diameter of ball or roller set in mm

4.3.2 Viscosity Ratio (K)

The viscosity ratio (k) is an indicator of the quality of the lubricant film formation. For adequate lubrication film between rolling element and raceways at operating temperature, the lubricant must have minimum viscosity. The condition of the lubricant is described by the viscosity ratio (k) as the ratio of the actual kinematic viscosity (ν) to the reference kinematic viscosity (ν_1). The kinematic viscosity (ν) is considered when the lubricant is at operating temperature.

$$k = \frac{\nu}{\nu_1}$$

The formula for calculating reference kinematic viscosity (ν_1) as per ISO281:2007 :

$$\nu_1 = 45\,000 n^{-0.83} D_{pw}^{-0.5} \quad \text{for } n \leq 1\,000 \text{ r/min}$$

$$\nu_1 = 4\,500 n^{-0.5} D_{pw}^{-0.5} \quad \text{for } n > 1\,000 \text{ r/min}$$

where ,

n is the rpm and D_{pw} is the pitch diameter of ball or roller set in mm

Considering EP additive as per ISO281:

For viscosity ratio, $k < 1$ and contamination factor, $e_c \geq 0.2$ calculation can be carried out using $k=1$ if a lubricant with proven effective EP additive is used. In this case the life modification factor, a_{iso} shall be limited to ≤ 3 . If the calculated value of a_{iso} for the actual k is greater than 3 then this value can be used in calculation.

4.3.3 Contamination factor, (e_c)

The factor is used to consider the contamination level of the lubricant. The life reduction caused by contamination depends on lubricant film thickness, size and distribution of solid contaminant particles and types of contaminants (soft, hard etc.). The values for solid contamination can be from the table, Factor e_c

Contamination level	e_c	
	$D_{pw} < 100\text{mm}$	$D_{pw} \geq 100\text{mm}$
Extreme cleanliness Particle size of order of lubricant film thickness laboratory conditions	1	1
High cleanliness Oil filtered through extremely fine filter: conditions typical for bearings greased for life and sealed	0.8 to 0.6	0.9 to 0.8
Normal cleanliness Oil filtered through fine filter: conditions typical for bearings greased for life and shielded	0.6 to 0.5	0.8 to 0.6
Slight contamination	0.5 to 0.3	0.6 to 0.4
Typical contamination Conditions typical of bearings without seals: coarse filtering: wear particles from surroundings	0.3 to 0.1	0.4 to 0.2
Severe contamination Bearing environment heavily contaminated and bearings arrangement with inadequate sealing	0.1 to 0	0.1 to 0
Very severe contamination	0	0

D_{pw} is the pitch diameter of ball or roller set in mm

Note: For advance and detailed method for calculation of e_c factor for different lubrication method in grease and oil (bath or circulation), refer ISO 16889 and ISO 4406 standards.

4.4 Basic Static Load Rating

The Static load is defined as a load acting on a non-rotating bearing. Permanent deformation appears in rolling elements and raceways under static load of moderate magnitude and increases gradually with increasing load. The permissible static load, therefore, depends upon the permissible magnitude of permanent deformation.

Experience shows that total permanent deformation of 0.0001 times of the rolling element diameter, occurring at the most heavily loaded rolling element and raceway contact can be tolerated in most bearing applications without impairment of bearing operation.

In certain applications where subsequent rotation of the bearing is slow and where smoothness and friction requirements are not too exacting, a much greater total permanent deformation can be permitted. On the other hand, where extreme smoothness is required or friction requirements are critical, less-total permanent deformation may be tolerated.

For purpose of establishing comparative ratings, the basic static load rating therefore, is defined as that static radial load which corresponds to a total permanent deformation of rolling element and raceway at the most heavily stressed contact set at 0.0001 times of the rolling element diameter. It applies to pure radial load for radial bearing and pure axial load for thrust bearing.

In single row angular contact bearing, the basic static load rating relates to the radial component of the load, which causes a purely radial displacement of the bearing rings in relation to each other.

The maximum applied load values for contact stress occurring at the rolling element and raceway contact points are as follows:

For ball bearing	4200MPa
For self aligning ball bearing	4600MPa
For roller bearing	4000MPa

The static equivalent load is defined as that static radial load, which, if applied to Deep Groove Ball bearings, Angular Contact or Roller bearings would cause the same total permanent deformation at the most heavily stressed rolling element and raceway contact as that which occurs under the actual conditions of loading. For thrust bearings the static equivalent load is defined as that static, central, purely axial load which, if applied, would cause the same total permanent deformation at the most heavily stressed rolling element and raceway contact as that which occurs under the actual condition of loading.

4.5 Life Factor for Applications

Life factor f_h

Service Requirements	< 1.0	1.0-2.0	2.0-2.5	2.5-3.0	3.0-3.5	3.5-4.0	4.0-5.0	5.0
Machines used occasionally	Door mechanisms measuring instruments							
Equipment for short period or intermittent service interruption permission		Medical equipment	Household appliances, electric hand tools, agriculture machines, lifting tackles in shop					
Intermittent service machines high reliability				Power station auxiliary equipment, construction machines, Crane sheaves elevators, Conveyors, deck cranes, Cranes	Crane Sheaves			
Machines used for 8 hours a day but not always in full operation		Automobiles, motorcycles, internal grinding spindles, ore tub axles	Buses, Trucks	Wood working machines, gear drives, plunger pumps vibrating screens	Small electric motors, grinding spindles, boring machine spindles rotary crushers, industrial Wagon axles	Lathe spindles, press flywheels printing machines	Agitators important gear units	
Machines fully used for 8 hours			Small rolling mill rollnecks	Large rolling mill rollnecks, rolling mill table rollers, excavators centrifugal separators continuous operation conveyors	Industrial electric motors, blowers, air conditioners street car or freight wagon axles, general machinery in shop, continuous operation cranes	Large electric motors, rolling mill gear units plastic extruders, rubber-plastics calendar rolls, railway vehicle axles, traction motors, conveyors in general use	Locomotive axles, railway vehicle gear units, false twist textile machines	
Machines continuously used for 24 hours a day					Loom	Electric motors in shop compressors, pumps	Textile machines, mine winches, iron industry conveyors	Papermaking machine, main rolls machines
Machines continuously used for 24 hours a day with maximum reliability pumps								Power station equipments, watersupply equipments for urban areas, mine drain

5. ACCURACY AND TOLERANCES

The accuracy of rolling bearings is classified as dimensional accuracy and running accuracy.

Dimensional accuracy indicates the tolerance and tolerance limits of boundary dimensions as well as the tolerance limits of width variations and of the taper of tapered bore. Running accuracy indicates the tolerance limits of outside cylindrical surface runout with side, radial runout, side runout with bore and axial runout.

5.1 Dimensional Accuracy

Dimensional accuracies of a bearing include the acceptable deviations for bearing boundary dimensions i.e. bore diameter, outer diameter, assembled bearing width. Form errors of individual rings are also included in dimensional accuracies. Inner Ring form errors are- single plane bore diameter variation- V_{dp} (roundness), mean single plane bore diameter variation- V_{dmp} (taper), width variation- V_B s (parallelism of side faces), raceway roundness & taper, flatness of faces and Outer Ring form errors are - single plane outside diameter variation- V_{Dp} (roundness), mean single plane outside diameter variation- V_{Dmp} (taper), width variation- V_C s (parallelism of side faces), raceway roundness & taper, flatness of faces.

5.2 Running Accuracy (As per ISO: 1132-1 & 2)

5.2.1 Radial Runout

- a **Radial runout of assembled bearing inner ring, K_{ia} (radial bearing)**: Difference between the largest and the smallest of the radial distances between the bore surface of the inner ring, in different angular positions of this ring, and a point in fixed position relative to the outer ring. At the angular position of the point mentioned, or on each side and close to it, rolling elements are to be in contact with both the inner and outer ring raceways and (in a tapered roller bearing) the cone back face rib, the bearing parts being otherwise in normal relative positions.

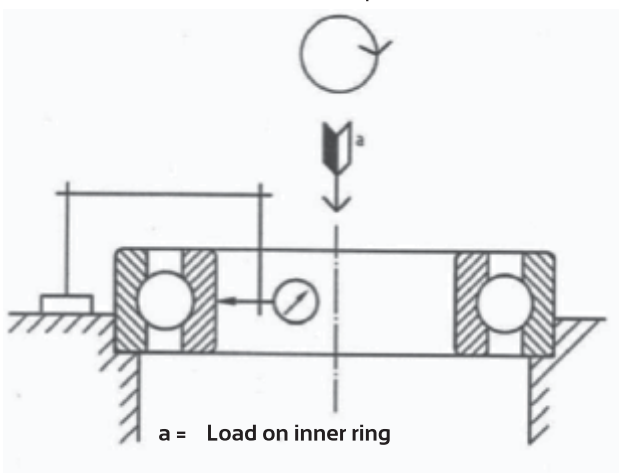

K_{ia} MEASUREMENT OF BALL BEARING

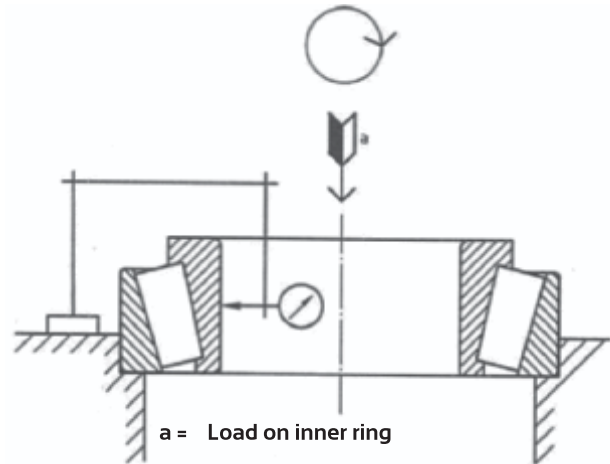

K_{ia} MEASUREMENT OF TAPER ROLLER BEARING

- b **Radial runout of assembled bearing outer ring, K_{ea} (radial bearing)**: Difference between the largest and the smallest of the radial distances between the outside surface of the outer ring, in different angular positions of this ring, and a point in a fixed position relative to the inner ring. At the angular position of the point mentioned, or on each side and close to it, rolling elements are to be in contact with both the Inner and outer ring raceways and (in a tapered roller bearing) the cone back face rib, the bearing parts being otherwise in normal positions.

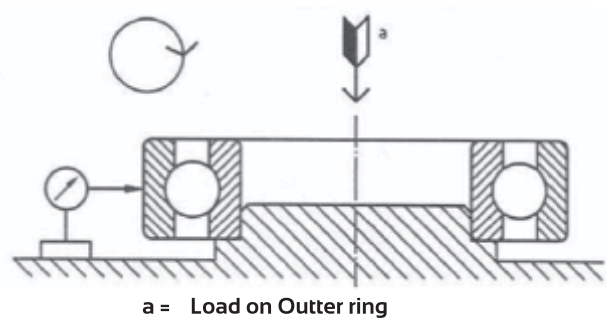

K_{ea} MEASUREMENT OF BALL BEARING

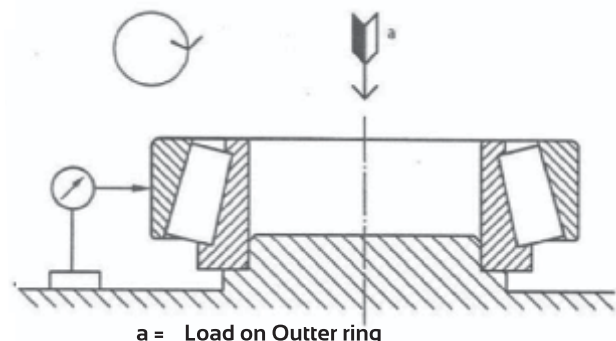

K_{ea} MEASUREMENT OF TAPER ROLLER BEARING

5.2.2 Face runout with raceway

- a **Assembled bearing inner ring face runout with raceway, S_{ia} (groove type radial ball bearing)** : Differences between the largest and the smallest of the axial distances between the reference face of the inner ring, in different relative angular positions of this ring, at a radial distance from the inner ring axis equal to half the inner ring raceway contact diameter, and a point in a fixed position relative to the outer ring. The inner and the outer ring raceways are to be in contact with all the balls.

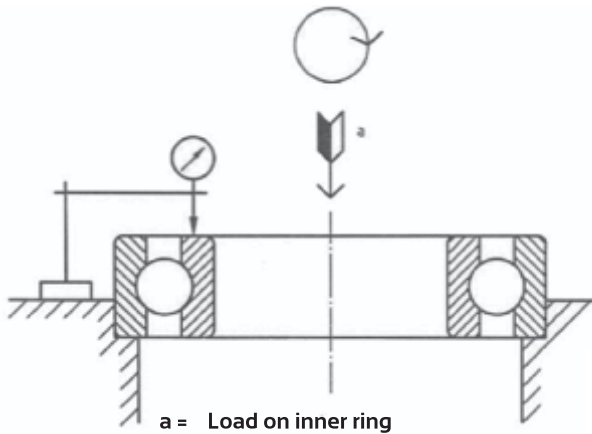

S_{ia} MEASUREMENT OF BALL BEARING

- b **Assembled bearing cone back face runout with raceway, S_{ia} (tapered roller bearing)** : Difference between the largest and the smallest of the axial distances between the cone back face, in different angular positions of the cone, at a radial distance from the cone axis equal to half the cone raceway contact diameter and a point in a fixed position relative to the cup. The cone and cup raceways and the cone back face rib are to be in contact with all the rollers, the bearing parts being otherwise in normal relative positions.

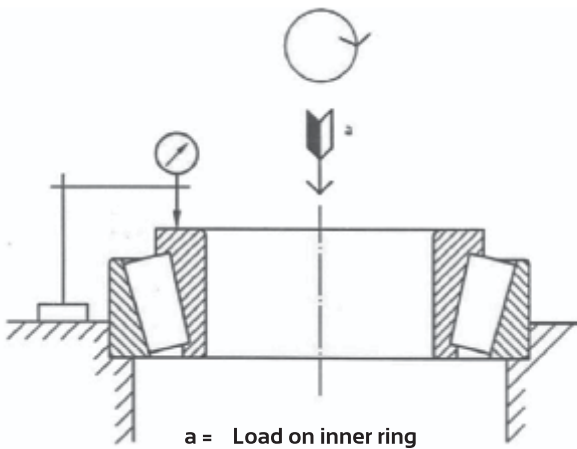

S_{ia} MEASUREMENT OF TAPER ROLLER BEARING

- c **Assembled bearing outer ring face runout with raceway S_{ea} (groove type radial ball bearing)** : Difference between the largest and the smallest of the axial distances between the reference face of the outer ring, in different relative angular positions of this ring, at a radial distance from the outer ring axis equal to half the outer ring raceway contact diameter, and a point in a fixed position relative to the inner ring. The inner and outer ring raceways are to be in contact with all the balls.

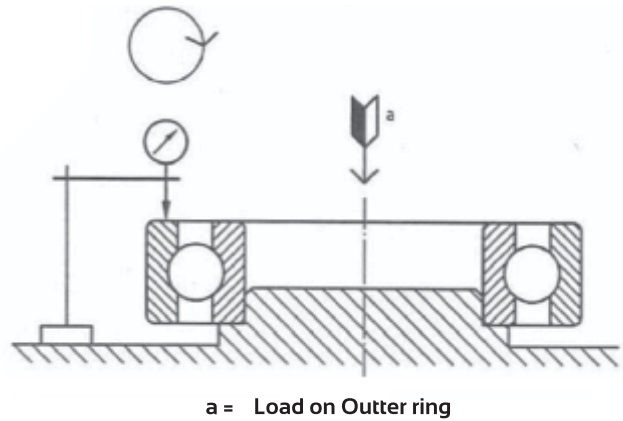

S_{ea} MEASUREMENT OF BALL BEARING

- d **Assembled bearing cup back face runout with raceway S_{ea} (tapered roller bearing)** : Difference between the largest and the smallest of the axial distances between the cup back face, in different angular positions of the cup, at a radial distance from the cup axis equal to half the cup raceway contact diameter, and a point in a fixed position relative to the cone. The cone and cup raceways and the cone back face rib are to be in contact with all the rollers, the bearing parts being otherwise in normal relative positions.

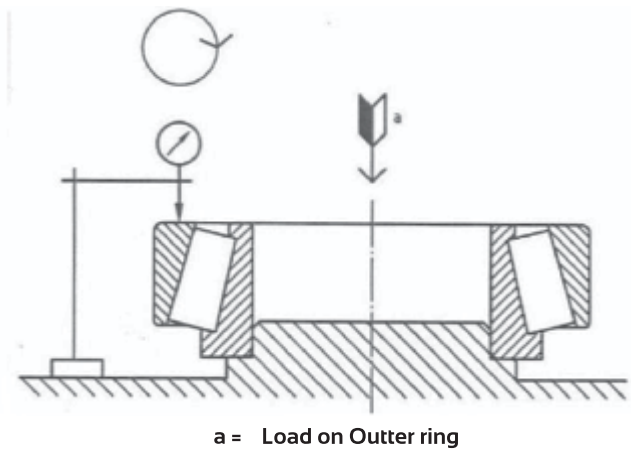

S_{ea} MEASUREMENT OF TAPER ROLLER BEARING

5.2.3 Face runout with bore

Face runout with bore, S_d (inner ring reference face): Difference between the largest and the smallest of the axial distances between a plane perpendicular to the ring axis and the reference face of the ring, at a radial distance from the axial of half the inner ring raceway contact diameter.

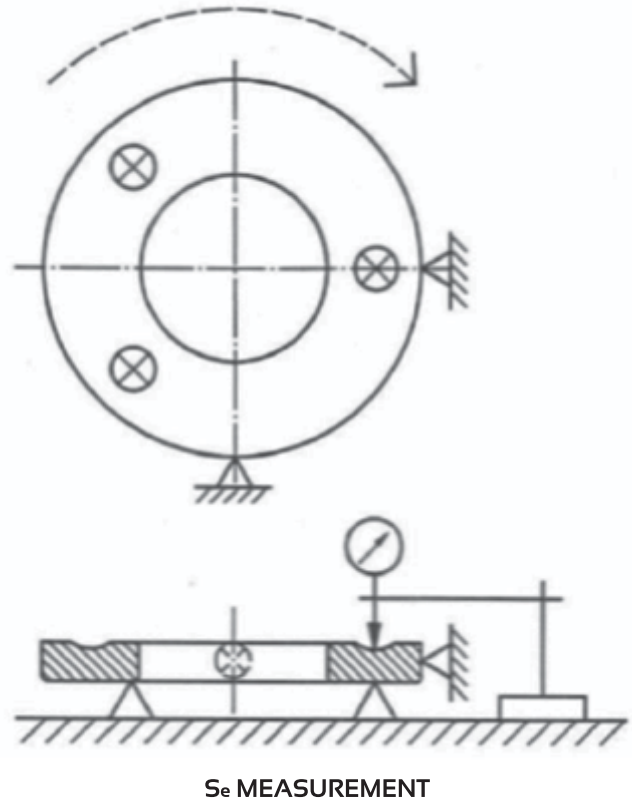
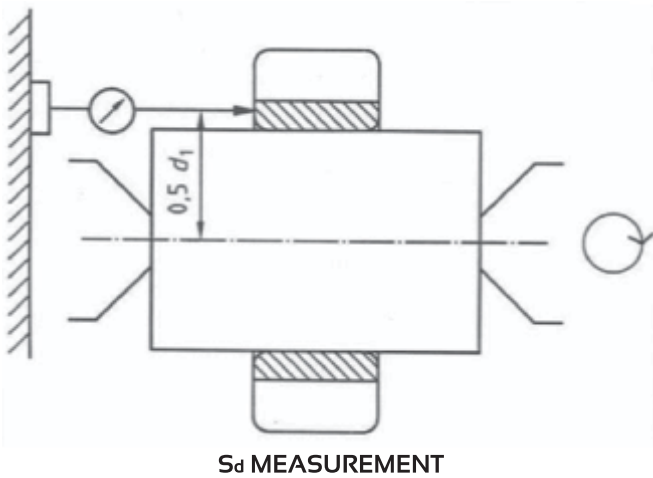

5.2.4 Raceway parallelism with face

Raceway parallelism with face, S_{i0} or S_{e0} (inner or outer ring of groove type radial ball bearing reference face): Difference between the largest and the smallest of the axial distances between the plane tangential to the reference face and the middle of the raceway.

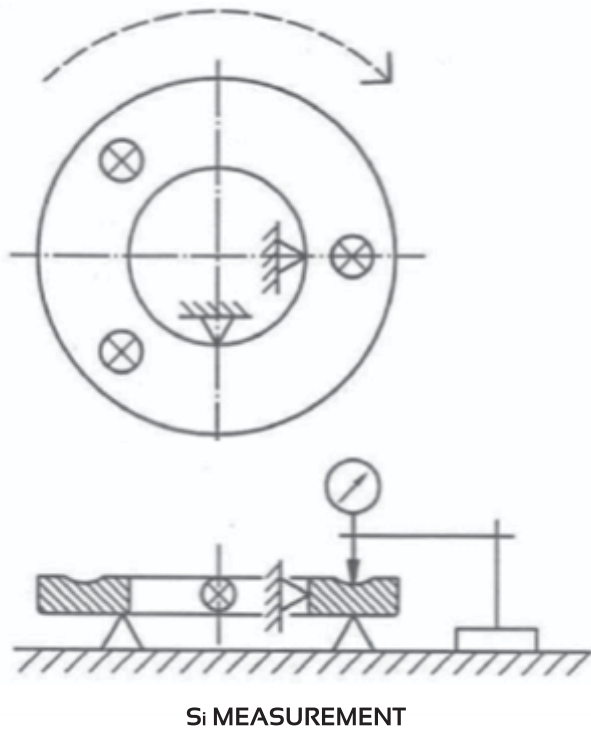

5.2.5 Outside surface inclination

Variation of outside surface generatrix inclination with face, S_D (outer ring basically cylindrical surface reference face): Total variation of the relative position in a radial direction parallel with the plane tangential to the reference face of the outer ring, of points on the same generatrix of the outside surface at a distance from the side faces of the ring equal to the maximum limits of the axial chamfer dimension.

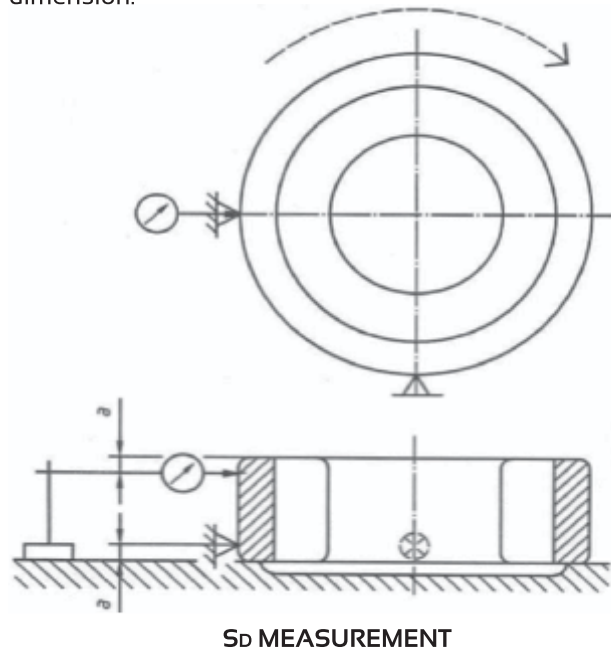

5.2.6 Thickness-variation

a **Inner ring raceway to bore thickness variation, K_i (radial bearing)** : Difference between the largest and the smallest of the radial distances between the bore surface and the middle of a raceway on the outside of the ring.

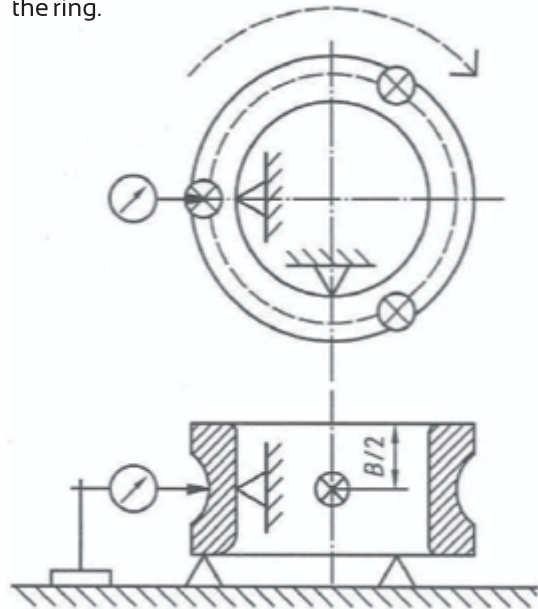

K_i MEASUREMENT

b **Outer ring raceway to outside surface thickness variation, K_e (radial bearing)** : Difference between the largest and the smallest of the radial distances between the outside surface and the middle of a raceway on the inside of the ring.

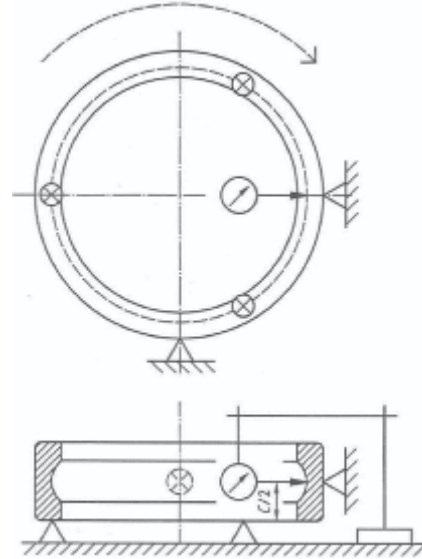

K_e MEASUREMENT

Table for 5.1 & 5.2 Bearing Types, Applicable standards and Comparison of tolerance classes among all standards

Bearing type		Applicable standards	Tolerance classes & comparison among standards					Reference table no.
Radial ball bearings		ISO 492	Class 0,6X	Class 6	Class 5	Class 4	Class 2	Table 5.3.1, 5.3.2
		JIS B 1514	Class 0,6X	Class 6	Class 5	Class 4	Class 2	
		DIN 620	P0	P6	P5	P4	P2	
		ABMA Std.20	ABEC -1	ABEC -3	ABEC -5	ABEC -7	ABEC -9	
Radial roller bearings (except tapered roller bearings)		ISO 492	Class 0,6X	Class 6	Class 5	Class 4	Class 2	Table 5.3.1, 5.3.2
		JIS B 1514	Class 0,6X	Class 6	Class 5	Class 4	Class 2	
		DIN 620	P0	P6	P5	P4	P2	
		ABMA Std.20	RBEC -1	RBEC -3	RBEC -5	-	-	
Tapered roller bearings	metric series	ISO 492	Class 0,6X	Class 6	Class 5	Class 4	Class 2	Table 5.4.1, 5.4.2
		JIS B 1514	Class 0,6X	Class 6	Class 5	Class 4	Class 2	
		DIN 620	P0	P6	P5	P4	P2	
		ABMA Std.19.1	Class K	Class N	Class C	Class B	Class A	
	inch series	ISO 578	Class 4	-	Class 3	Class 0	Class 00	Table 5.5.1, 5.5.2, 5.5.3
		JIS B 1514	Class 0,6X	Class 6	Class 5	Class 4	Class 2	
		DIN 620	P0	P6	P5	P4	P2	
		ABMA Std.19	Class 4	Class 2	Class 3	Class 0	Class 00	
Thrust bearings (all types)		ISO 199	Normal class	Class 6	Class 5	Class 4	-	Table 5.6.1, 5.6.2
		JIS B 1514	Class 0,6X	Class 6	Class 5	Class 4	Class 2	
		DIN 620	P0	P6	P5	P4	P2	
		ABMA Std.	-	-	-	-	-	

5.3 Tolerances For Radial Bearings (except Tapered Roller Bearings) (As per ISO 492, IS 5692)

-Symbols

d	= bearing bore diameter, nominal
d_i	= basic diameter at theoretical large end of a basically tapered bore
Δd_s	= deviation of a single bore diameter
Δd_{mp}	= single plane mean bore diameter deviation (for a basically tapered bore Δd_{mp} refers only to the theoretical small end of bore)
Δd_{lmp}	= mean bore diameter deviation at theoretical large end of a basically tapered bore
V_{dp}	= bore diameter variation in single radial plane
V_{dmp}	= mean bore diameter variation (this applies only to a basically cylindrical bore)
α	= half of the total angle of inner ring bore (for taper bore bearings)
D	= bearing outside diameter, nominal
D_i	= outer ring flange outside diameter, nominal
ΔD_S	= deviation of single outside diameter
ΔD_{mp}	= single plane mean outside diameter deviation
V_{Dp}	= outside diameter variation in a single radial plane
V_{Dmp}	= mean outside diameter variation
B	= inner ring width, nominal
ΔB_S	= deviation of single inner ring width
V_{BS}	= inner ring width variation
C	= outer ring width, nominal
C_i	= outer ring flange width, nominal
ΔC_S	= deviation of single outer ring width
ΔC_{iS}	= deviation of a single outer ring flange width
V_{CS}	= outer ring width variation
$V_{C_{iS}}$	= outer ring flange width variation
K_{ia}	= radial runout of assembled bearing inner ring
K_{ea}	= radial runout of assembled bearing outer ring
S_d	= inner ring reference face (back face, where applicable) runout with bore
S_D	= variation of bearing outside surface generatrix inclination with outer ring reference face (back face)
S_{D_i}	= variation of bearing outside surface generatrix inclination with flange back face
S_{ia}	= assemble bearing inner ring face (backface) runout with raceway
S_{ea}	= assembled bearing outer ring face (backface) runout with raceway
S_{eal}	= assembled bearing outer ring flange backface runout with raceway

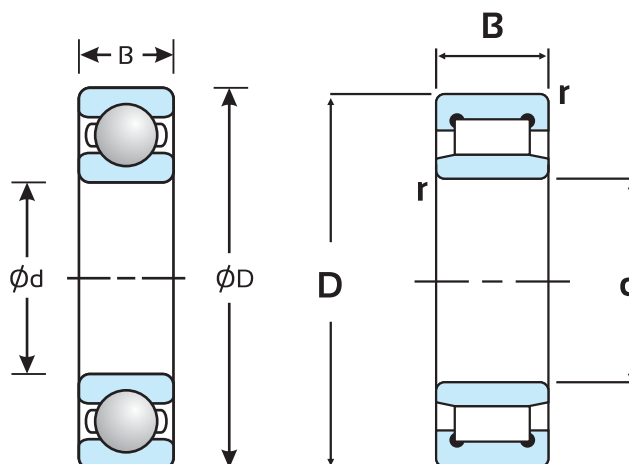

Tolerances for Normal Tolerance Class Radial Bearings (Except Tapered Roller Bearings) – METRIC SERIES

TABLE 5.3.1: INNER RING

Values in microns												
d (mm)		Δ dmp		Vdp			Vdmp	Kia	ΔBS			VBS
				Diameter Series					High	Normal	Modified	
				9	0,1	2,3,4						
Over	Including	High	Low	Max			Max	Max	High	Low		Max
2.5	10	0	-8	10	8	6	6	10	0	-120	-250	15
10	18	0	-8	10	8	6	6	10	0	-120	-250	20
18	30	0	-10	13	10	8	8	13	0	-120	-250	20
30	50	0	-12	15	12	9	9	15	0	-120	-250	20
50	80	0	-15	19	19	11	11	20	0	-150	-380	25
80	120	0	-20	25	25	15	15	25	0	-200	-380	25
120	180	0	-25	31	31	19	19	30	0	-250	-500	30
180	250	0	-30	38	38	23	23	40	0	-300	-500	30
250	315	0	-35	44	44	26	26	50	0	-350	-500	35
315	400	0	-40	50	50	30	30	60	0	-400	-630	40
400	500	0	-45	56	56	34	34	65	0	-450	-	50
500	630	0	-50	63	63	38	38	70	0	-500	-	60
630	800	0	-75	94	94	55	55	80	0	-750	-	70
800	1000	0	-100	125	125	75	75	90	0	-1000	-	80

TABLE 5.3.2: OUTER RING

Values in microns													
D (mm)		Δ Dmp		VDP				Vdmp	Kea	Δcs			Vcs
				Open Bearings			Capped Bearing			High	Low	Max	
				Diameter Series									
Over	Including	High	Low	9	0,1	2,3,4	2,3,4	Max	Max	Max	High	Low	Max
6	18	0	-8	10	8	6	10	6	15	Identical to ΔBS and VBS of Inner ring of same bearing			
18	30	0	-9	12	9	7	12	7	15				
30	50	0	-11	14	11	8	16	8	20				
50	80	0	-13	16	13	10	20	10	25				
80	120	0	-15	19	19	11	26	11	35				
120	150	0	-18	23	23	14	30	14	40				
150	180	0	-25	31	31	19	38	19	45				
180	250	0	-30	38	38	23	-	23	50				
250	315	0	-35	44	44	26	-	26	60				
315	400	0	-40	50	50	30	-	30	70				
400	500	0	-45	56	56	34	-	34	80				
500	630	0	-50	63	63	38	-	38	100				
630	800	0	-75	94	94	55	-	55	120				
800	1000	0	-100	125	125	75	-	75	140				
1000	1250	0	-125	155	155	94	-	94	160				
1250	1600	0	-160	200	200	120	-	120	190				
1600	2000	0	-200	250	250	150	-	150	220				
2000	2250	0	-250	310	310	190	-	190	250				

5.4 Tolerance For Tapered Roller Bearing (METRIC SERIES) NORMAL TOLERANCE CLASS

Tolerances For Tapered Roller Bearings

Symbols (Applicable for metric and inch series)

d	= bearing bore diameter, nominal
Δd_s	= deviation of a single bore diameter
Δd_{mp}	= single plane mean bore diameter deviation (for a basically tapered bore Δd_{mp} refers only to the theoretical small end of bore)
V_{dp}	= bore diameter variation in single radial plane
V_{dmp}	= mean bore diameter variation (this applies only to a basically cylindrical bore)
D	= bearing outside diameter, nominal
D_l	= outer ring flange outside diameter, nominal
ΔD_s	= deviation of a single outside diameter
ΔD_{mp}	= single plane mean outside diameter deviation
V_{DP}	= outside diameter variation in a single radial plane
V_{Dmp}	= mean outside diameter variation
B	= inner ring width, nominal
T	= bearing width, nominal
ΔT_s	= deviation of the actual bearing width
T_1	= effective width of inner sub-unit, nominal
ΔB_s	= deviation of single inner ring width
C	= outer ring width, nominal
ΔC_s	= deviation of single outer ring width
K_{ia}	= radial runout of assembled bearing inner ring
K_{ea}	= radial runout of assembled bearing outer ring
S_d	= inner ring reference face (backface, where applicable) runout with bore
SD	= variation of bearing outside surface generatrix inclination with outer ring reference face (back face)
S_{ia}	= assemble bearing inner ring face (backface) runout with raceway
S_{ea}	= assembled bearing outer ring face (backface) runout with raceway
ΔT_{1s}	= deviation of the actual effective width of inner sub unit
T_2	= effective width of outer sub-unit, nominal
T_{2s}	= deviation of the actual effective width of outer sub-unit

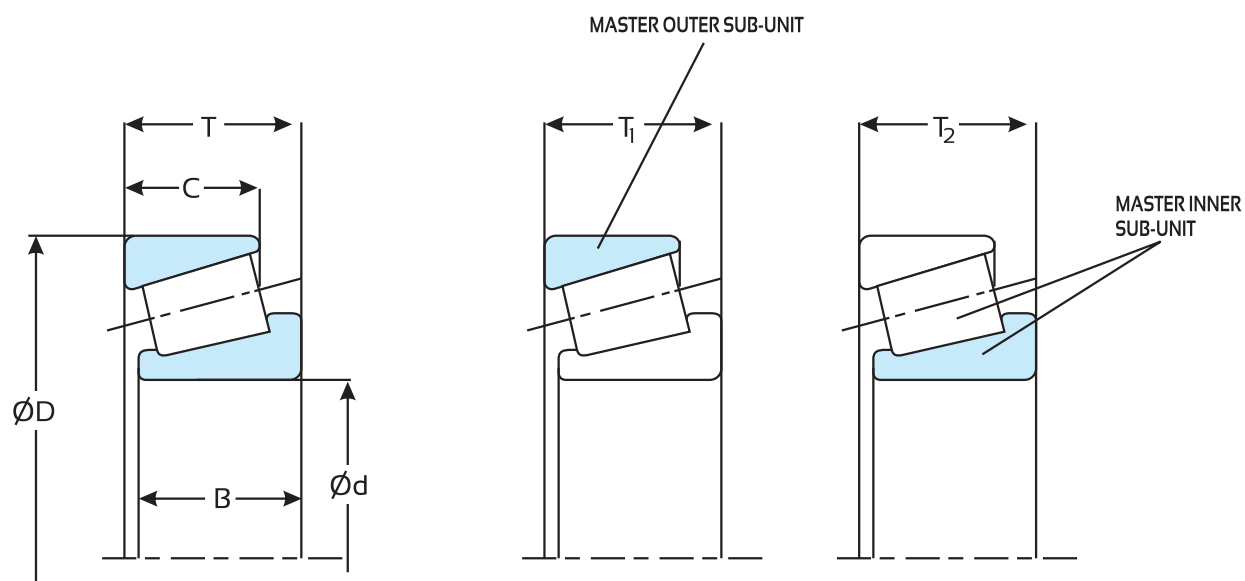

SYMBOLS FOR TAPERED ROLLER BEARINGS

Metric Series (ISO 492 / IS 7460)

TABLE 5.4.1 - INNER RING

Tolerance value in microns

d (mm)		Δ dmp		Vdp	Vdmp	Kia
Over	Including	High	Low	Max	Max	Max
10	18	0	-12	12	9	15
18	30	0	-12	12	9	18
30	50	0	-12	12	9	20
50	80	0	-15	15	11	25
80	120	0	-20	20	15	30
120	180	0	-25	25	19	35
180	250	0	-30	30	23	50
250	315	0	-35	35	26	60
315	400	0	-40	40	30	70
400	500	0	-45	45	34	80
500	630	0	-50	50	38	90
630	800	0	-75	75	56	105
800	1000	0	-100	100	75	120
1000	1250	0	-125	125	94	140
1250	1600	0	-160	160	120	160

TABLE 5.4.2 - OUTER RING

Tolerance value in microns

D (mm)		Δ Dmp		VDp	VDmp	K _{ea}
Over	Including	High	Low	Max	Max	Max
18	30	0	-12	12	9	18
30	50	0	-14	14	11	20
50	80	0	-16	16	12	25
80	120	0	-18	18	14	35
120	150	0	-20	20	15	40
150	180	0	-25	25	19	45
180	250	0	-30	30	23	50
250	315	0	-35	35	26	60
315	400	0	-40	40	30	70
400	500	0	-45	45	34	80
500	630	0	-50	50	38	100
630	800	0	-75	75	56	120
800	1000	0	-100	100	75	140
1000	1250	0	-125	125	84	165
1250	1600	0	-160	160	120	190
1600	2000	0	-200	200	150	230

TABLE 5.4.3 WIDTH - INNER AND OUTER RING, SINGLE ROW BEARING AND SINGLE ROW SUBUNITS

Tolerance value in microns

d mm		Δ Bs		Δ Cs		Δ Ts		Δ T1s		Δ T2s	
Over	Including	High	Low	High	Low	High	Low	High	Low	High	Low
10	18	0	-120	0	-120	+200	0	+100	0	+100	0
18	30	0	-120	0	-120	+200	0	+100	0	+100	0
30	50	0	-120	0	-120	+200	0	+100	0	+100	0
50	80	0	-150	0	-150	+200	0	+100	0	+100	0
80	120	0	-200	0	-200	+200	-200	+100	-100	+100	-100
120	180	0	-250	0	-250	+350	-250	+150	-150	+200	-100
180	250	0	-300	0	-350	+350	-250	+150	-150	+200	-100
250	315	0	-350	0	-350	+350	-250	+150	-150	+200	-100
315	400	0	-400	0	-400	+400	-400	+200	-200	+200	-200
400	500	0	-450	0	-450	-	-	-	-	-	-
500	630	0	-500	0	-500	-	-	-	-	-	-
630	800	0	-750	0	-750	-	-	-	-	-	-
800	1000	0	-1000	0	-1000	-	-	-	-	-	-
1000	1250	0	-1200	0	-1200	-	-	-	-	-	-
1250	1600	0	-1500	0	-1500	-	-	-	-	-	-

Table 5.4.4 WIDTH DEVIATIONS OF ASSEMBLED DOUBLE ROW AND FOUR ROW TAPERED ROLLER BEARINGS

d (mm)		Overall width/height deviation of assembled double rows tapered roller bearings		Overall width/height deviation of assembled four rows tapered roller bearings	
Over	Including	High	Low	High	Low
10	18	-	-	-	-
18	30	-	-	-	-
30	50	+240	-240	-	-
50	80	+300	-300	-	-
80	120	+400	-400	+500	-500
120	180	+500	-500	+600	-600
180	250	+600	-600	+750	-750
250	315	+700	-700	+900	-900
315	400	+800	-800	+1000	-1000
400	500	+900	-900	+1200	-1200
500	630	+1000	-1000	+1200	-1200
630	800	+1500	-1500	+1500	-1500
800	1000	+1500	-1500	+1500	-1500

5.5 Tolerance For Tapered Roller Bearings (Inch Series) (ISO 578)

TABLE 5.5.1 INNER RING BORE, INNER RING WIDTH AND BEARING WIDTH

Tolerance class	d		Δds		ΔBS		ΔTs	
	Over	Including	High	Low	High	Low	High	Low
Inch Value in 0.0001 inch								
4	0	3	+5	0	+30	-100	+80	0
	(3)	4	+10	0	+30	-100	+80	0
	(4)	6	+10	0	+30	-100	+140	-100
3	0	6	+5	0	+30	-100	+80	-80
0	0	6	+5	0	+30	-100	+80	-80
00	0	6	+3	0	+30	-100	+80	-80
mm Value in 0.001 mm								
	0	76.2	+13	0	+76	-254	+203	0
4	76.2	101.6	+25	0	+76	-254	+203	0
	101.6	152.4	+25	0	+76	-254	+356	-254
3	0	152.4	+13	0	+76	-254	+203	-203
0	0	152.4	+13	0	+76	-254	+203	-203
00	0	152.4	+8	0	+76	-254	+203	-203

NOTE : The Cage may project beyond the bearing width.

TABLE 5.5.2 OUTER RING OUTSIDE DIAMETER, OUTER RING WIDTH AND ASSEMBLED BEARING RUNOUTS

Tolerance class	D		ΔDS		Δcs		Kia Kea Max	Sia Sea Max
	Over	Including	High	Low	High	Low		
Inch Value in 0.0001 inch								
4	0	12	+10	0	+20	-100	20	20
	(12)	14	+20	0	+20	-100	20	20
3	0	12	+5	0	+20	-100	3	3
	(12)	14	+10	0	+20	-100	7	7
0	0	12	+5	0	+20	-100	1.5	1.5
00	0	10.5	+3	0	+20	-100	0.75	0.75
mm Value in 0.001 mm								
4	0	304.8	+25	0	+51	-254	51	51
	(304.8)	355.6	+51	0	+51	-254	51	51
3	0	304.8	+13	0	+51	-254	8	8
	(304.8)	355.6	+25	0	+51	-254	18	18
0	0	304.8	+13	0	+51	-254	4	4
00	0	266.7	+8	0	+51	-254	2	2

NOTE : The Tolerance for the outside diameter of an outer ring flange D1 is h9 (See ISO 286)

TABLE 5.5.3 EFFECTIVE WIDTH OF SUB-UNIT, TOLERANCE CLASS 4 (Normal Tolerance Class)

d		$\Delta T1s$		$\Delta T2s$	
Over	Including	High	Low	High	Low
Inch Value in 0.0001 inch					
-	4	+40	0	+40	0
4	6	+60	-60	+80	-40
mm Value in 0.001 mm					
-	101.6	+102	0	+102	0
(101.6)	152.4	+152	-152	+203	-102

5.6 Tolerance For Thrust Ball and Roller Bearings (As per ISO 199)

-Symbols

- d = bore diameter of shaft washer, single-direction bearing
- d_2 = bore diameter of shaft washer, double-direction bearing
- Δd_{mp} = deviation of mean bore diameter in a single plan of shaft, single-direction bearing
- Δd_{2mp} = deviation of mean bore diameter in a single plan of shaft, double-direction bearing
- D = outside diameter of housing washer
- ΔD_{mp} = deviation of mean outside diameter in a single of plan of housing washer
- S_e = variation in thickness between housing washer raceway and back face
note - Applies only to ball thrust bearings and cylindrical roller thrust bearings with 90° contact angle
- S_i = variation in thickness between shaft washer receway and back face
note - Applies only to ball thrust bearings and cylindrical roller thrust bearings with 90° contact angle
- T = bearing height, single-direction bearing
- T_1 = bearing height, double direction bearing
- ΔT_s = deviation of the actual bearing height, single-direction bearing
- ΔT_{1s} = deviation of the actual bearing height, double-direction bearing
- V_{dp} = variation of bore diameter in a single plane of shaft washer, single-direction bearing
- V_{d2p} = variation of bore diameter in a single plane of shaft washer, double-direction bearing
- V_{Dp} = variation of outside diameter in a single radial plane of housing washer

Single direction thrust bearing

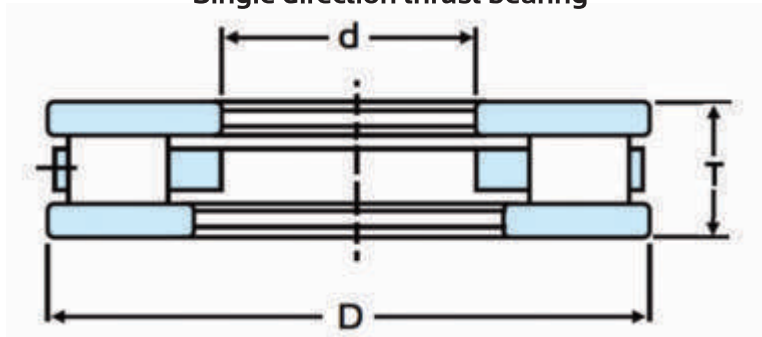

Double direction thrust bearing

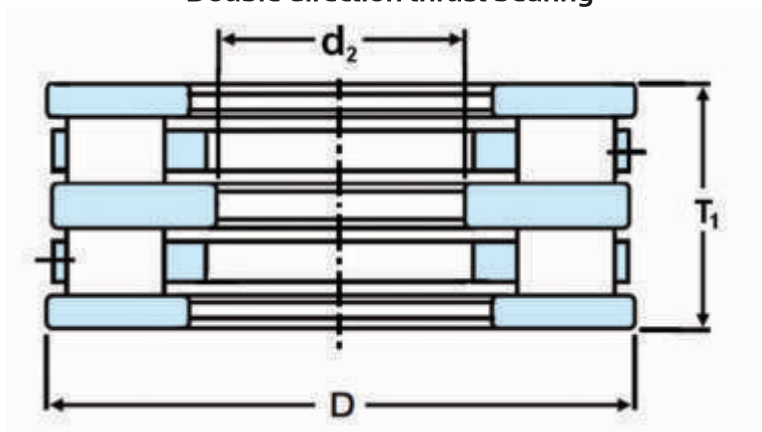

**Table 5.6.1 SHAFT WASHER AND BEARING HEIGHT
(AS PER ISO 199/NORMAL TOLERANCE CLASS)**

Tolerance values in micrometers

d and d ₂		Δ dmp, Δ d ₂ mp		V _{d_p} , V _{d₂p}		S _i		DT _s		DT _{is}	
>	<	high	low	max.	max.	high	low	high	low	high	low
-	18	0	-8	6	10	+20	-250	+150	-400		
18	30	0	-10	8	10	+20	-250	+150	-400		
30	50	0	-12	9	10	+20	-250	+150	-400		
50	80	0	-15	11	10	+20	-300	+150	-500		
80	120	0	-20	15	15	+25	-300	+150	-500		
120	180	0	-25	19	154	+25	-400	+200	-600		
180	250	0	-30	23	20	+30	-400	+250	-600		
250	315	0	-35	26	25	+40	-400	-	-		
315	400	0	-40	30	30	+40	-500	-	-		
400	500	0	-45	34	30	+50	-500	-	-		
500	630	0	-50	38	35	+60	-600	-	-		
630	800	0	-75	55	40	+70	-750	-	-		
800	1000	0	-100	75	45	+80	-1000	-	-		
1000	1250	0	-125	95	50	+100	-1400	-	-		
1250	1600	0	-160	120	60	+120	-1600	-	-		
1600	2000	0	-200	150	75	+140	-1900	-	-		
2000	2500	0	-250	190	90	+160	-2300	-	-		

NOTE : For double-direction bearings the values apply only up to and including d₂=190mm.

**Table 5.6.1 SHAFT WASHER AND BEARING HEIGHT
(AS PER ISO 199/NORMAL TOLERANCE CLASS)**

Tolerance values in micrometers

D mm		Δ Dmp		V _{D_p}	S _e
		high			max.
10	18	0	-11	8	Identical to S _i of shaft washer of same bearing
18	30	0	-13	10	
30	50	0	-16	12	
50	80	0	-19	14	
80	120	0	-22	17	
120	180	0	-25	19	
180	250	0	-30	22	
250	315	0	-35	26	
315	400	0	-40	30	
400	500	0	-45	34	
500	630	0	-50	38	
630	800	0	-75	55	
800	1000	0	-100	75	
1000	1250	0	-125	95	
1250	1600	0	-160	120	
1600	2000	0	-200	150	
2000	2500	0	-250	190	
2500	2800	0	-300	225	

NOTE : For double-direction bearings the values apply only up to and including D=360mm.

5.7 Chamfer Dimensions Limits For Roller Bearings (AS PER ISO : 582 / IS:5934)

5.7.1 Metric Series Radial Bearings and Tapered Roller Bearings

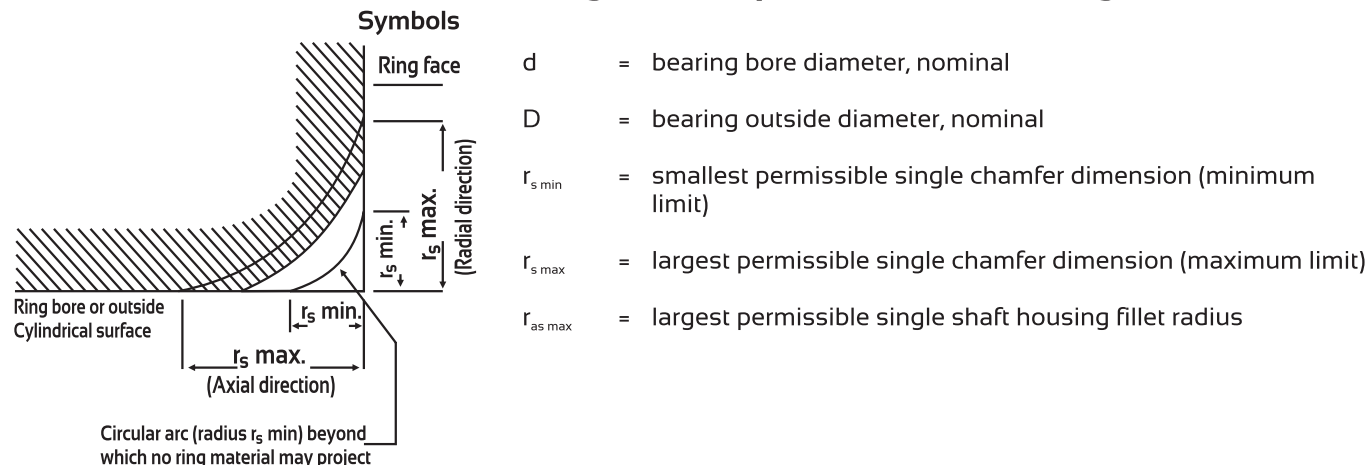

TABLE 5.7.1 TAPERED ROLLER BEARINGS OF METRIC SERIES

Dimensions in Millimetres

Cone (d) or Cup (D) back face chamfer				
$r_s \min$	d or D		$r_s \max$	
	>	<	radial direction	axial direction
0.3	-	40	0.7	1.4
	40	-	0.9	1.6
0.6	-	40	1.1	1.7
	40	-	1.3	2
1.0	-	50	1.6	2.5
	50	-	1.9	3
1.5	-	120	2.3	3
	120	250	2.8	3.5
	250	-	3.5	4
2	-	120	2.8	4
	120	250	3.5	4.5
	250	-	4	5
2.5	-	120	3.5	5
	120	250	4	5.5
	250	-	4.5	6
3	-	120	4	5.5
	120	250	4.5	6.5
	250	400	5	7
	400	-	5.5	7.5
4	-	120	5	7
	120	250	5.5	7.5
	250	400	6	8
	400	-	6.5	8.5
5	-	180	6.5	8
	180	-	7.5	9
6	-	180	7.5	10
	180	-	9	11

TABLE 5.7.2 RADIAL BEARINGS EXCEPT TAPERED ROLLER BEARINGS

Dimensions in Millimetres

$r_s \min$	d or D		$r_s \max$	
	>	<	radial direction	axial direction
0.3	-	40	0.6	1
	40	-	0.8	1
0.6	-	40	1	2
	40	-	1.3	2
1	-	50	1.5	3
	50	-	1.9	3
1.1	-	120	2	3.5
	120	-	2.5	4
1.5	-	120	2.3	4
	120	-	3	5
2	-	80	3	4.5
	80	220	3.5	5
	220	-	3.8	6
2.1	-	280	4	6.5
	280	-	4.5	7
2.5	-	100	3.8	6
	100	280	4.5	6
	280	-	5	7
3	-	280	5	8
	280	-	5.5	8
4	-	-	6.5	9

TABLE 5.7.3 THRUST BEARINGS

Dimensions in Millimetres

r_s min	r_s max radial and axial direction
0.05	0.1
0.08	0.16
0.1	0.2
0.15	0.3
0.2	0.5
0.3	0.8
0.6	1.5
1	2.2
1.1	2.7
1.5	3.5
2	4
2.1	4.5
3	5.5
4	6.5
5	8
6	10

Comparison between nominal chamfer dimension & minimum chamfer limits

TABLE 5.7.4 RADIAL BEARINGS EXCEPT TAPERED ROLLER BEARINGS AND THRUST BEARINGS

Dimensions in Millimetres

r_s nom	r_s min
0.1	0.05
0.15	0.08
0.2	0.1
0.3	0.15
0.4	0.2
0.5	0.3
1	0.6
1.5	1
2	1.1*
2.5	1.5
3	2
3.5	2.1*
4	3
5	4
6	5
8	6
10	7.5
12	9.5
15	12
18	15
22	19

TABLE 5.7.5 TAPERED ROLLER BEARINGS

Dimensions in Millimetres

r nom	Cup back face chamfer		Cup back face chamfer	
	r_s min	r_s min (ISO 582-1972)	r_s min	r_s min* (ISO 582-1972)
0.5	0.3	0.3	0.3	0.3
1	0.6	0.6	0.6	0.6
1.5	1	1	1	1
2	1.5	1	1.5	1
2.5	2	1.5	1.5	1.5
3	2.5	2	2	2
3.5	3	2	2.5	2
4	4	3	3	3
5	5	4	4	4
6	6	5	5	5

* In ISO :582-1972 the r_s min values were 1 and 2 mm respectively.

5.7.2 CHAMFER DIMENSIONS LIMITS FOR TAPERED ROLLER BEARING OF INCH SERIES AS PER ISO : 1123)

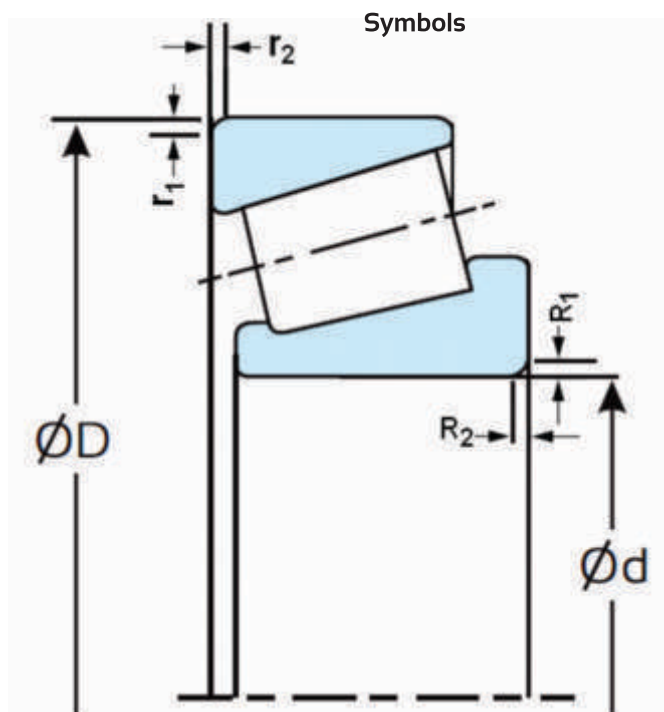

- d = inner ring bore diameter
- D = outer ring outside diameter
- R = nominal dimension of inner ring back face chamfer
- R₁ = height of inner ring back face chamfer
- R₂ = width of inner ring back face chamfer
- r = nominal dimension of outer ring back face chamfer
- r₁ = height of outer ring back face chamfer
- r₂ = width of outer ring back face chamfer

Table 5.7.6 INNER RING CHAMFER DIMENSION LIMITS

Bore diameter d nominal		Chamfer height R ₁		Chamfer Width R ₂	
Over	Incl.	min.	max.	min.	max.
Values in inches					
-	2	R	R + 0.015	R	R + 0.035
(2)	4	R	R + 0.020	R	R + 0.050
(4)	10	R	R + 0.025	R	R + 0.070
Values in millimeters					
-	50,8	R	R + 0,38	R	R + 0,89
(50,8)	101,6	R	R + 0,51	R	R + 1,27
(101,8)	254	R	R + 0,64	R	R + 1,78

Table 5.7.7 OUTER RING CHAMFER DIMENSION LIMITS

Outside Diameter D nominal		Chamfer height r ₁		Chamfer Width r ₂	
Over	Incl.	min.	max.	min.	max.
Values in inches					
-	4	r	r + 0.023	r	r + 0.042
(4)	6.625	r	r + 0.025	r	r + 0.046
(16.625)	10.5	r	r + 0.033	r	r + 0.053
(10.5)	14	r	r + 0.067	r	r + 0.067
Values in millimeters					
-	101,6	r	r + 0.58	r	r + 1,07
(101,61)	168,275	r	r + 0.64	r	r + 1,17
(168,275)	266,7	r	r + 0.84	r	r + 1,35
(266,7)	355,6	r	r + 1,70	r	r + 1,70

The value of r is identical with that r_{min} in ISO/R 355, Part 1.

5.8 Basic Tapered Bore, Taper 1:12

The normal taper angle (half the cone angle):

$$\alpha = 2^{\circ}23'9.4'' = 2.38594 = 0.041643 \text{ rad}$$

The basic diameter at the theoretical large end of the bore :

$$d_1 = d + 1/12B$$

The tolerances for a tapered bore, taper 1:12 comprise

a) a mean diameter tolerance, given by limits for the actual mean diameter deviation at the theoretical small end of the bore, Δd_{mp}

b) a taper tolerance diameter, given by limits for the difference between the actual mean diameter deviations at the two ends of

the bore, $\Delta d_{imp} - \Delta d_{mp}$; and

c) a tolerance for the diameter variation, V_{dp} given by a maximum value applying in any radial plane of the bore

Normal Tolerance

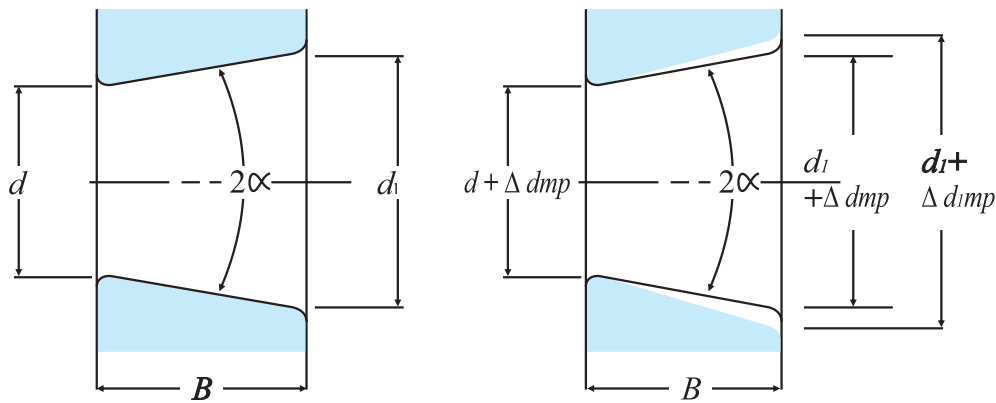

Theoretical tapered hole

Tapered hole having dimensional difference of the average bore diameter within the flat surface

Unit μm

d (mm)		Δd_{mp}		$\Delta d_{imp} - \Delta d_{mp}$		V_{dp}
Over	Including	High	Low	High	Low	Max.
	10	+22	0	+15	0	9
10	18	+27	0	+18	0	11
18	30	+33	0	+21	0	13
30	50	+39	0	+25	0	16
50	80	+46	0	+30	0	19
80	120	+54	0	+35	0	22
120	180	+63	0	+40	0	40
180	250	+72	0	+46	0	46
250	315	+81	0	+52	0	52
315	400	+89	0	+57	0	57
400	500	+97	0	+63	0	63
500	630	+110	0	+70	0	70
630	800	+125	0	+80	0	--
800	1,000	+140	0	+90	0	--
1,000	1,250	+165	0	+105	0	--
1,250	1,600	+195	0	+125	0	--

6. BEARING INTERNAL CLEARANCE

Bearing Internal clearance (Initial clearance) is the amount of internal clearances, a bearing has before being installed on a shaft or on a housing as shown in figure when either the inner/outer ring is fix and the other ring is free to move. Displacement can take place either in axial/radial direction. This amount of displacement (Radially or Axially) is termed by internal clearance, and depending on the direction, is called the radial clearance or the axial internal clearance. When the internal clearance of a bearing is measured, a slight measurement load is applied to the race ways so the internal clearance may be measured accurately. However, at this time, a slight amount of elastic deformation of the bearing occurs under the measurement load, and the clearance measurement value is slightly larger than the two clearances. This discrepancy between the two bearing clearances and the increased amount due to elastic deformation must be compensated. These compensated values are given in Table below

TABLE: 6.1 ADJUSTMENT OF RADIAL INTERNAL CLEARANCE OF DEEP GROOVE BALL BEARINGS BASED ON MEASURED LOAD

Unit μm							
Nominal Bore Diameter d (mm)		Measuring Load		Radial Clearance Increase			
over	incl.	N	(Kgf)	C2	CN	C3	C4
10	18	24.5	(2.5)	3-4	4	4	4
18	50	49	(5)	4-5	5	5	5
50	200	147	(15)	6-8	9	9	9

Radial clearance of the bearing is built up for following reasons:

1. Accommodate the reduction of clearance in a bearing due to interference for inner ring on the shaft or outer ring in the housing.
2. Accommodate the minor changes in the dimensions of parts without affecting the bearing performance.
3. Compensate for the differential expansion of the two rings when the inner ring of a bearing operates at a higher temperature than the outer ring.
4. It allows a slight misalignment between the shaft and the housing, and thereby prevents the premature failure of the bearing
5. It affects the end play of radial ball bearing, and also affects their capacity for carrying axial loads, the greater the radial clearance the greater the capacity for supporting axial load.

IMPORTANT

Once ball and roller bearings are mounted and running, a small amount of radial internal or running clearance is normally desirable. In the case of bearings under radial load, quieter running is generally obtained when this clearance is minimum.

Radial bearings are made with following different ranges of radial internal clearance-C2, Normal, C3 and C4

C2 These bearings have the smallest amount of radial internal clearance. They should only be used where freedom from all shake is required in the assembled bearings and there is no possibility of the initial radial internal clearances being eliminated by external causes. Therefore, special attention must be given to the seating dimensions as the expansion of the inner ring or contraction of the outer ring may cause tight bearings. In this respect a C2 bearing should not be used unless recommended by us.

CN: This grade of radial internal clearance is intended for use where only one ring is made an interference fit, and there is no appreciable loss of clearance due to temperature difference. Ball and roller bearings for general engineering applications are usually of this clearance.

C3: This grade of radial internal clearance should be used when both rings of a bearing are made an interference fit, or when only one ring is an interference fit but there is likely to be some loss of clearance due to temperature differences. It is the grade normally used for radial ball bearings that take axial loading but for some purposes even bearings with C4 clearance may be required.

C4: Where there will be some loss of clearance due to temperature differences and both rings are interference fit, this grade of radial internal clearance is employed. One example of its use is in bearings for traction motors. Customers should always consult us before ordering bearings with this grade of radial internal clearance.

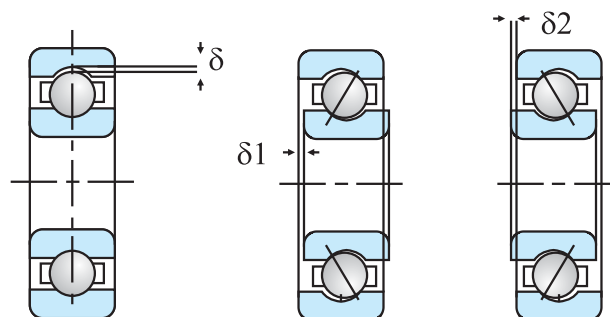

Radial Clearance = δ

Axial Clearance = $\delta_1 + \delta_2$

6.1 Internal Clearance Selection

The internal clearance of a bearing under operating conditions (effective clearance) is usually smaller than the same bearing's initial clearance before being installed and operated. This is due to several factors including bearing fit, the difference in temperature between the inner and outer rings, etc. As a bearing's operating clearance has an effect on bearing life, heat generation, vibration, noise, etc.; care must be exercised in selecting the most suitable operating clearance.

Effective internal clearance :

The internal clearance differential between the initial clearance and the operating (effective) clearance (the amount of clearance reduction caused by interference fits, or clearance variation due to the temperature difference between the inner and outer rings) can be calculated by the following formula :

$$\delta_{\text{eff}} = \delta_o - (\delta_f + \delta_t)$$

where,

δ_{eff} = Effective internal clearance (mm)

δ_o = Bearing internal clearance (mm)

δ_f = Reduced amount of clearance due to interference (mm)

δ_t = Reduced amount of clearance due to temperature differential of inner and outer rings (mm)

Reduced internal clearance due to interference :

When bearings are installed with interference fits on shafts and in housings, the inner ring will expand and the outer ring will contract ; thus reducing the bearing's internal clearance. The amount of expansion or contraction varies depending on the shape of the bearing, the shape of the shaft or housing, dimensions of the respective parts, and the type of materials used. **The differential can range from approximately 70% to 90% of the effective interference.**

$$\delta_f = (0.70-0.90) \Delta d_{\text{eff}}$$

where,

δ_f = Reduced amount of clearance due to interference (mm)

Δd_{eff} = Effective interference (mm)

Reduced internal clearance due to inner/outer ring temperature difference :

During operation, normally the outer ring will be from 5° to 10°C cooler than the inner ring or rotating parts. However, if the cooling effect of the housing is large, the shaft is connected to a heat source, or a heated substance is conducted through the hollow shaft, the temperature difference between the two rings can be even greater.

The amount of internal clearance is thus further reduced by the differential expansion of the two rings.

$$\delta_t = \alpha \cdot \Delta T \cdot D_o$$

where,

δ_t = Amount of reduced clearance due to heat differential

α = Bearing steel linear expansion coefficient $12.5 \times 10^{-6}/^{\circ}\text{C}$

ΔT = Inner/outer ring temperature differential ($^{\circ}\text{C}$)

D_o = Outer ring raceway diameter (mm)

Outer ring raceway diameter, D. Value can be calculated by using formula as given below:

For ball bearings and spherical roller bearings

$$D_o = 0.20 (d + 4D)$$

For roller bearings (except self-aligning) $D_o = 0.25 (d + 3D)$

where,

d = Bearing bore diameter (mm)

D = Bearing outside diameter (mm)

6.2 Radial Internal Clearance values as per ISO : 5753/IS:5935

6.2.1 Deep groove ball bearings

TABLE 6.2 RADIAL INTERNAL CLEARANCE FOR DEEP GROOVE BALL BEARINGS WITH CYLINDRICAL BORE

Clearance value in microns

Bore diameter d (mm)		Group 2 (C2)		Group N (CN)		Group 3 (C3)		Group 4 (C4)		Group 5 (C5)	
Over	Incl.	Min.	Max.	Min.	Max.	Min.	Max.	Min.	Max.	Min.	Max.
2.5	6	0	7	2	13	8	23	-	-	-	-
6	10	0	7	2	13	8	23	14	29	20	37
10	18	0	9	3	18	11	25	18	33	25	45
18	24	0	10	5	20	13	28	20	36	28	48
24	30	1	11	5	20	13	28	23	41	30	53
30	40	1	11	6	20	15	33	28	46	40	64
40	50	1	11	6	23	18	36	30	51	45	73
50	65	1	15	8	28	23	43	38	61	55	90
65	80	1	15	10	30	25	51	46	71	65	105
80	100	1	18	12	36	30	58	53	84	75	120
100	120	2	20	15	41	36	66	61	97	90	140
120	140	2	23	18	48	41	81	71	114	105	160
140	160	2	23	18	53	46	91	81	130	120	180
160	180	2	25	20	61	53	102	91	147	135	200
180	200	2	30	25	71	63	117	107	163	150	230
200	225	2	35	25	85	75	140	125	195	175	265
225	250	2	40	30	95	85	160	145	225	205	300
250	280	2	45	35	105	90	170	155	245	225	340
280	315	2	55	40	115	100	190	175	270	245	370
315	355	3	60	45	125	110	210	195	300	275	410
355	400	3	70	55	145	130	240	225	340	315	460
400	450	3	80	60	170	150	270	250	380	350	510
450	500	3	90	70	190	170	300	280	420	390	570
500	560	10	100	80	210	190	330	310	470	440	630
560	630	10	110	90	230	210	360	340	520	490	690
630	710	20	130	110	260	240	400	380	570	540	760
710	800	20	140	120	290	270	450	430	630	600	840
800	900	20	160	140	320	300	500	480	700	670	940
900	1000	20	170	150	350	330	550	530	770	740	1040
1000	1120	20	180	160	380	360	600	580	850	820	1150
1120	1250	20	190	170	410	390	650	630	920	890	1260

6.2.2 Cylindrical Roller Bearings

TABLE 6.3 RADIAL INTERNAL CLEARANCE OF CYLINDRICAL ROLLER BEARINGS (INTERCHANGEABLE) WITH CYLINDRICAL BORE

Clearance value in microns

Bore diameter d (mm)		Group 2 (C2)		Group N (CN)		Group 3 (C3)		Group 4 (C4)		Group 5 (C5)	
Over	Incl.	Min.	Max.	Min.	Max.	Min.	Max.	Min.	Max.	Min.	Max.
-	10	0	25	20	45	35	60	50	75	-	-
10	24	0	25	20	45	35	60	50	75	65	90
24	30	0	25	20	45	35	60	50	75	70	95
30	40	5	30	25	50	45	70	60	85	80	105
40	50	5	35	30	60	50	80	70	100	95	125
50	65	10	40	40	70	60	90	80	110	110	140
65	80	10	45	40	75	65	100	90	125	130	165
80	100	15	50	50	85	75	110	105	140	155	190
100	120	15	55	50	90	85	125	125	165	180	220
120	140	15	60	60	105	100	145	145	190	200	245
140	160	20	70	70	120	115	165	165	215	225	275
160	180	25	75	75	125	120	170	170	220	250	300
180	200	35	90	90	145	140	195	195	250	275	330
200	225	45	105	105	165	160	220	220	280	305	365
225	250	45	110	110	175	170	235	235	300	330	395
250	280	55	125	125	195	190	260	260	330	370	440
280	315	55	130	130	205	200	275	275	350	410	485
315	355	65	145	145	225	225	305	305	385	455	535
355	400	100	190	190	280	280	370	370	460	510	600
400	450	110	210	210	310	310	410	410	510	565	665
450	500	110	220	220	330	330	440	440	550	625	735

TABLE 6.4 RADIAL INTERNAL CLEARANCE OF CYLINDRICAL ROLLER BEARINGS (NON-INTERCHANGEABLE) WITH CYLINDRICAL BORE

Clearance value in microns

Nominal Bore diameter d (mm)		C1NA		C2NA		NA ^①		C3NA		C4NA		C5NA	
Over	Incl.	Min	Max.	Min	Max.	Min	Max.	Min	Max.	Min	Max.	Min	Max.
-	10	5	10	10	20	20	30	35	45	45	55	-	-
10	18	5	10	10	20	20	30	35	45	45	55	65	75
18	24	5	10	10	20	20	30	35	45	45	55	65	75
24	30	5	10	10	25	25	35	40	50	50	60	70	80
30	40	5	12	12	25	25	40	45	55	55	70	80	95
40	50	5	15	15	30	30	45	50	65	65	80	95	110
50	65	5	15	15	35	35	50	55	75	75	90	110	130
65	80	10	20	20	40	40	60	70	90	90	110	130	150
80	100	10	25	25	45	45	70	80	105	105	125	155	180
100	120	10	25	25	50	50	80	95	120	120	145	180	205
120	140	15	30	30	60	60	90	105	135	135	160	200	230
140	160	15	35	35	65	65	100	115	150	150	180	225	260
160	180	15	35	35	75	75	110	125	165	165	200	250	285
180	200	20	40	40	80	80	120	140	180	180	220	275	315
200	225	20	45	45	90	90	135	155	200	200	240	305	350
225	250	25	50	50	100	100	150	170	215	215	265	330	380
250	280	25	55	55	110	110	165	185	240	240	295	370	420
280	315	30	60	60	120	120	180	205	265	265	325	410	470
315	355	30	65	65	135	135	200	225	295	295	360	455	520
355	400	35	75	75	150	150	225	255	330	330	405	510	585
400	450	45	85	85	170	170	255	285	370	370	455	565	650

① For bearings with normal clearance, only NA is added to bearing numbers, Ex. NU305NA

TABLE 6.5 RADIAL INTERNAL CLEARANCE OF CYLINDRICAL ROLLER BEARINGS (NON-INTERCHANGEABLE) with cylindrical bore

Clearance value in microns

Nominal Bore diameter d (mm)		C9NA ^②		CONA ^②		C1NA		C2NA		NA ^①		C3NA	
Over	Incl.	Min	Max.	Min	Max.	Min	Max.	Min	Max.	Min	Max.	Min	Max.
-	10	5	5	7	17	10	20	20	30	35	45	45	55
10	18	5	10	7	17	10	20	20	30	35	45	45	55
18	24	5	10	7	17	10	20	20	30	35	45	45	55
24	30	5	10	10	20	10	25	25	35	40	50	50	60
30	40	5	12	10	20	12	25	25	40	45	55	55	70
40	50	5	15	10	20	15	30	30	45	50	65	65	80
50	65	5	15	10	20	15	35	35	50	55	75	75	90
65	80	10	20	15	30	20	40	40	60	70	90	90	110
80	100	10	25	20	35	25	45	45	70	80	105	105	125
100	120	10	25	20	35	25	50	50	80	95	120	120	145
120	140	15	30	25	40	30	60	60	90	105	135	135	160
140	160	15	35	30	45	35	65	65	100	115	150	150	180
160	180	15	35	30	45	35	75	75	110	120	165	165	200
180	200	20	40	30	50	40	80	80	120	140	180	180	220
200	225	20	45	35	55	45	90	90	105	155	200	200	240
225	250	25	50	40	65	50	10	100	150	170	210	215	265
250	280	25	55	40	65	55	110	110	165	185	240	240	295
280	315	30	60	45	75	60	120	120	180	205	265	265	325
315	355	30	65	45	75	65	135	135	200	225	295	295	360
355	400	35	75	50	90	75	150	150	225	255	330	330	405
400	450	45	85	60	10	85	170	170	255	285	370	370	455
450	500	50	95	70	115	95	190	190	285	315	410	410	505

② C9NA, CONA and C1NA are applied only to precision bearings of Class 5 and higher.

6.2.3 Double row self-aligning ball bearing

TABLE 6.6 DOUBLE ROW SELF ALIGNING BALL BEARINGS WITH CYLINDRICAL BORE

Clearance value in microns

Bore diameter d (mm)		Group 2 (C2)		Group N (CN)		Group 3 (C3)		Group 4 (C4)		Group 5 (C5)	
Over	Incl.	Min.	Max.	Min.	Max.	Min.	Max.	Min.	Max.	Min.	Max.
2.5	6	1	8	5	15	10	20	15	25	21	33
6	10	2	9	6	17	12	25	19	33	27	42
10	14	2	10	6	19	13	26	21	35	30	48
14	18	3	12	8	21	15	28	23	37	32	50
18	24	4	14	10	23	17	30	25	39	34	52
24	30	5	16	11	24	19	35	29	46	40	58
30	40	6	18	13	29	23	40	34	53	46	66
40	50	6	19	14	31	25	44	37	57	50	71
50	65	7	21	16	36	30	50	45	69	62	88
65	80	8	24	18	40	35	60	54	83	76	108
80	100	9	27	22	48	42	70	64	96	89	124
100	120	10	31	25	56	50	83	75	114	105	145
120	140	10	38	30	68	60	100	90	135	125	175
140	160	15	44	35	80	70	120	110	161	150	210

TABLE 6.7 DOUBLE ROW SELF ALIGNING BALL BEARINGS WITH TAPERED BORE

Clearance value in microns

Bore diameter d (mm)		Group 2 (C2)		Group N (CN)		Group 3 (C3)		Group 4 (C4)		Group 5 (C5)	
Over	Incl.	Min.	Max.	Min.	Max.	Min.	Max.	Min.	Max.	Min.	Max.
18	24	7	17	13	26	20	33	28	42	37	55
24	30	9	20	15	28	23	39	33	50	44	62
30	40	12	24	19	35	29	46	40	59	52	72
40	50	14	27	22	39	33	52	45	65	58	79
50	65	18	32	27	47	41	61	56	80	73	99
65	80	23	39	35	57	50	75	69	98	91	123
80	100	29	47	42	68	62	90	84	116	109	144
100	120	35	56	50	81	75	108	100	139	130	170
120	140	40	68	60	98	90	130	120	165	155	205
140	160	45	74	65	110	100	150	140	191	180	240

6.2.4 Double row self-aligning roller bearing

TABLE 6.8 DOUBLE ROW SPHERICAL ROLLER BEARINGS WITH CYLINDRICAL BORE

Clearance value in microns

Bore diameter d (mm)		Group 2 (C2)		Group N (CN)		Group 3 (C3)		Group 4 (C4)		Group 5 (C5)	
Over	Incl.	Min.	Max.	Min.	Max.	Min.	Max.	Min.	Max.	Min.	Max.
14	18	10	20	20	35	35	45	45	60	60	75
18	24	10	20	20	35	35	45	45	60	60	75
24	30	15	25	25	40	40	55	55	75	75	95
30	40	15	30	30	45	45	60	60	80	80	100
40	50	20	35	35	55	55	75	75	100	100	125
50	65	20	40	40	65	65	90	90	120	120	150
65	80	30	50	50	80	80	110	110	145	145	180
80	100	35	60	60	100	100	135	135	180	180	225
100	120	40	75	75	120	120	160	160	210	210	260
120	140	50	95	95	145	145	190	190	240	240	300
140	160	60	110	110	170	170	220	220	280	280	350
160	180	65	120	120	180	180	240	240	310	310	390
180	200	70	130	130	200	200	260	260	340	340	430
200	225	80	140	140	220	220	290	290	380	380	470
225	250	90	150	150	240	240	320	320	420	420	520
250	280	100	170	170	260	260	350	350	460	460	570
280	315	110	190	190	280	280	370	370	500	500	630
315	355	120	200	200	310	310	410	410	550	550	690
355	400	130	220	220	340	340	450	450	600	600	750
400	450	140	240	240	370	370	500	500	660	660	820
450	500	140	260	260	410	410	550	550	720	720	900
500	560	150	280	280	440	440	600	600	780	780	1000
560	630	170	310	310	480	480	650	650	850	850	1100
630	710	190	350	350	530	530	700	700	920	920	1190
710	800	210	390	390	580	580	770	770	1010	1010	1300
800	900	230	430	430	650	650	860	860	1120	1120	1440
900	1000	260	480	480	710	710	930	930	1220	1220	1570

TABLE 6.9 DOUBLE ROW SPHERICAL ROLLER BEARINGS WITH TAPERED BORE

Clearance value in microns

Bore diameter d (mm)		Group 2 (C2)		Group N (CN)		Group 3 (C3)		Group 4 (C4)		Group 5 (C5)	
Over	Incl.	Min.	Max.	Min.	Max.	Min.	Max.	Min.	Max.	Min.	Max.
18	24	15	25	25	35	35	45	45	60	60	75
24	30	20	30	30	40	40	55	55	75	75	95
30	40	25	35	35	50	50	65	65	85	85	105
40	50	30	45	45	60	60	80	80	100	100	130
50	65	40	55	55	75	75	95	95	120	120	160
65	80	50	70	70	95	95	120	120	150	150	200
80	100	55	80	80	110	110	140	140	180	180	230
100	120	65	100	100	135	135	170	170	220	220	280
120	140	80	120	120	160	160	200	200	260	260	330
140	160	90	130	130	180	180	230	230	300	300	380
160	180	100	140	140	200	200	260	260	340	340	430
180	200	110	160	160	220	220	290	290	370	370	470
200	225	120	180	180	250	250	320	320	410	410	520
225	250	140	200	200	270	270	350	350	450	450	570
250	280	150	220	220	300	300	390	390	490	490	620
280	315	170	240	240	330	330	430	430	540	540	680
315	355	190	270	270	360	360	470	470	590	590	740
355	400	210	300	300	400	400	520	520	650	650	820
400	450	230	330	330	450	450	570	570	720	720	910
450	500	260	270	270	490	490	630	630	790	790	1000
500	560	290	410	410	540	540	680	680	870	870	1100
560	630	320	460	460	600	600	760	760	980	980	1230
630	710	350	510	510	670	670	850	850	1090	1090	1360
710	800	390	370	370	750	750	960	960	1220	1220	1500
800	900	440	640	640	840	840	1070	1070	1370	1370	1690
900	1000	490	710	710	930	930	1190	1190	1520	1520	1860

7. LUBRICATION

Why Bearing Should be lubricated ?

Lubrication is an essential requirement for the proper operation of bearings.

The purpose of bearing lubrication is to prevent direct metallic contact between the various rolling and sliding elements. This is accomplished through the formation of a thin film of oil/grease on the contact surfaces.

The Advantages of lubrication

- * Protects the bearing from rust & corrosion.
- * Protects the bearing from the foreign particles.
- * Minimizes the friction between the races & rolling elements.
- * Reduces the friction arising out of elastic deformation of rolling elements when under load.
- * Facilitates the smooth running of bearing by minimizing noise.
- * Dissipates the heat from the bearing and helps to distribute the frictional heat uniformly throughout the bearing, which gets generated during operation.
- * Saves power losses by minimizing internal friction.
- * Helps the bearing to attain the required speed.
- * Helps to attain the anticipated life of the bearing.

Selection of lubricant:

- * Small size bearings operating at high speed, low viscosity oil is used
- * Large bearing carrying heavy load, lubricants with higher viscosity and additional additive properties may be used.
- * The lubricant must have sufficient lubricating capacity at the prevailing temperature
- * It must form a load sustaining lubricating film for prevailing load conditions.
- * It must have the capacity to absorb water to a certain extent, without affecting the lubricating capacity wherever the application demands.

When the Lubricant quality and quantity is inadequate, it results in the cage failure, inadequate lubrication may heat up cage and may break down the ball pockets. Due to break down of the lubricating films on raceways and rolling element surfaces it may develop scoring marks, which lead to premature failure of the bearing.

This condition may also result in the deformation of parts and when the bearing deformed parts rotate under load, sliding motion will take place instead of rolling motion and it ends up in premature bearing failure.

Table 7.1 Lubrication methods and characteristics

Method	Grease Lubrication	Oil Lubrication
Handling	□	△
Reliability	○	□
Cooling Effect	x	○
Seal Structure	○	△
Power loss	○	○
Environment Contamination	○	△
High speed rotation	x	○

□ : Very Good ○ : Good △ : Fair x : Poor

7.1 Types of Lubrication

7.1.1 Grease Lubrication

Grease type lubricants are relatively easy to handle & require only the simplest sealing devices and it also involves a minimum of design and maintenance requirements and thus offers an optimum economy. For these reasons, grease is most widely used lubricant for rolling bearings.

Grease is a semi-solid lubricant consisting of base oil, thickener and additives

A. Base Oil :

Mineral oils or synthetic oils such as silicon diester oils and fluorocarbon oils are mainly used as the base oil for grease. The lubricating properties of grease depend mainly on characteristics of its base oil. Therefore greases with low viscosity base oil are best suited for low temperature and high speeds. High viscosity base oils are best suited for heavy loads.

B. Thickening Agents :

Thickening agents are compounded with the base oils to maintain the semi-solid state of the grease. There are several types of metallic soaps such as lithium, sodium & calcium and inorganic thickeners such as silica gel & bentonite and heat resisting organic thickeners such as polyurea and fluoric compounds.

The various special characteristics of a grease, such as limiting temperature range, mechanical stability, water resistance, etc. depend largely on the type of thickening agent used. For example, a sodium based grease is generally poor in water resistance and lithium base greases are water repellent within the certain limits and may also be used in the case of moisture if corrosion inhibitors are added. Greases with betone, poly-urea and other non-metallic soaps as the thickening agent are generally superior in high temperature properties.

C. Additives :

Various additives are added to grease such as antioxidants, corrosion inhibitors and extreme pressure additives (EP Additives) to improve various properties.

EP additives are used in heavy load applications. For long use without replenishment, an antioxidant should be added.

D. Consistency:

Consistency indicate the stiffness and liquidity and expressed by a numerical index.

Greases are divided into various consistency classes according to the NLGI (National Lubricating grease Institute Scale). The NLGI values for this index indicate the relative softness of the grease, the larger the number the stiffer the grease. It is mainly determined by the amount of thickening agent used and the viscosity of the base oil. For rolling bearing lubrication grease with the NLGI numbers of 1, 2, & 3 are used.

TABLE 7.2 RELATIONSHIP BETWEEN CONSISTENCY AND APPLICATION OF GREASE

NLGI Consistency No.	Worked Penetration	Working conditions
0	355-385	<input type="checkbox"/> For centralised greasing use <input type="checkbox"/> When fretting is likely to occur
1	310-340	<input type="checkbox"/> For centralised greasing use <input type="checkbox"/> When fretting is likely to occur <input type="checkbox"/> For low temperature
2	265-295	<input type="checkbox"/> For general use <input type="checkbox"/> For selected ball bearings <input type="checkbox"/> For high temperature
3	220-250	<input type="checkbox"/> For general use <input type="checkbox"/> For selected ball bearings
4	175-205	<input type="checkbox"/> For high temperature <input type="checkbox"/> For special use

TABLE 7.3 CRITERIA FOR SUITABLE GREASE SELECTION

Working condition	Suitable Grease
• For smooth running (Low noise level)	• Grease of penetration class 2
• Vertical Mounting	• Grease with good adhesion properties of classes 3 & 4
• If outer ring rotation or centrifugal force on bearing	• Grease having additional quantity of thickener of class 2 to 4
• High Temperature	• Grease with Synthetic base oil and class of 3 & 4
• Low Temperature	• Low viscosity grease with suitable oil of class 1 & 2.
• Contaminated Environment	• Grease of class 3

For further detail you may contact our Technical Cell

E. Mixing Different Types of grease

In general, different brands and different kinds of grease must not be mixed because of the different additives they contain. Mixing grease with different types of thickeners may impair its composition and physical properties. However, if different greases must be mixed, at least greases with the same base oil and thickening agent should be selected. But even when the grease of the same base oil and thickening agent are mixed, the quality of the grease may still change due to difference in their additives.

Amount of Grease

The amount of grease used in any given situation will depend on the following factors :

- (1) Size & Shape of housing, (2) Space limitation, (3) Bearing's speed, (4) Operating Load, (5) Type of grease (6) Operating Conditions

As a general rule housing & bearing should be only filled with 30% to 60% of their capacities. Where speeds are high and temperature rise, needs to be kept to a minimum, reduced amount of grease should be used.

Excessive amount of grease causes temperature rise which in turn causes the grease to soften and may allow leakage. If excessive grease is used, oxidation and deterioration may cause lower lubricating efficiency.

Moreover the standard bearing space can be found by following formula,

$$V = K \cdot W$$

Where

- V : Quantity of bearing space open type (Cm³)
- K : Bearing Space Factor
- W : Mass of Bearing in Kg.
(Specific gravity of grease = 0.9)

TABLE 7.4 BEARING SPACE RATIO (K)

Bearing Type	Retainer Type	K
Ball Bearings ①	Pressed Retainer	61
NU-cylindrical Roller Bearings ②	Pressed Retainer	50
	Machined Retainer	36
N-cylindrical Roller Bearings ③	Pressed Retainer	55
	Machined Retainer	37
Tapered Roller Bearings	Machined Retainer	46
Spherical Roller Bearings	Pressed Retainer	35
	Machined Retainer	28

① Remove 160 Series ② Remove NU4 Series ③ Remove N4 Series
 In general, the permissible working temperature is limited by the degree of mechanical agitation to which the grease is subjected, and we shall be pleased to recommend suitable lubricants for varying conditions on receipt of necessary particulars

Before the bearings are set to work, they should be thoroughly charged with grease in such a manner as to ensure the efficient coating of all working surfaces. The housing should also be lightly packed with grease, it being important that a reserve supply of lubricant should be maintained in actual contact with the bearing to promote satisfactory and continuous lubrication. Over filling or cramming should, however, be avoided, for excessive greasing may cause overheating due to churning, and if two bearings are mounted in the same housing, they, for this reason, should be separated by distance pieces. If correctly applied, one charge of grease will last for a very long period, varying with the condition of working.

Grease Relubrication

Grease replenishment or exchange is required if the grease service life is shorter than the anticipated bearing life. The bearings are re-lubricated by means of grease guns through lubricating nipples. If frequent re-lubrication is required, grease pumps and volumetric metering units must be used. It is essential that the fresh grease displace the spent grease, so that the grease get exchanged, but overgreasing is prevented.

Grease Relubrication Quantities

Relubrication quantity L_1 for weekly to yearly re-lubricating $L_1 = D.B.X$ (in grams)

D = Outer dia of the bearing (mm)

B = Width of the bearing (mm)

		X
Weekly	:	0.0020
Fortnightly	:	0.0025
Monthly	:	0.0030
Yearly	:	0.004-0.005

Grease replenishment intervals can also be calculated by using following graph.

This chart indicates the replenishment interval for standard rolling bearing grease when used under normal operating conditions.

As operating temperature increases, the grease re-supply interval should be shortened accordingly.

Generally, for every 10°C increase in bearing temperature,

above 80°C, the lubrication period is reduced by exponent "1/1.5".

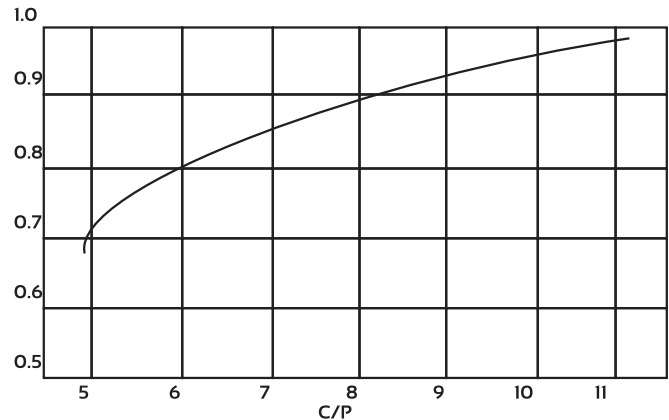
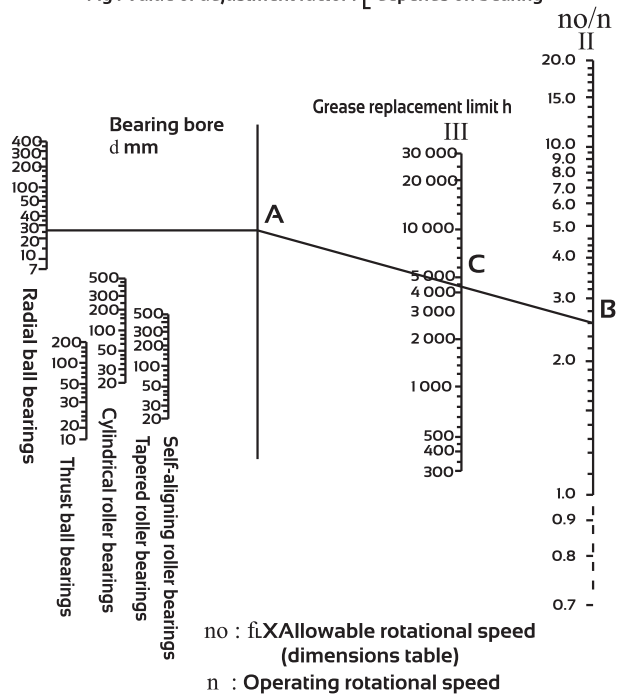

Fig : Value of adjustment factor F_L depends on bearing



Example : Find the grease lubrication interval for ball bearing 6205 with a radial load 1.4 kN operating at 4800 r/min

$Cr/Pr = 14/1.4 \text{ kN} = 10$ from fig. 2 adjusted load fL is 0.98

From the bearing tables the allowable speed for bearing 6205 is 13000 r/min & numbers of revolutions at a radial load of 1.4 kN are $n_o = 0.98 \times 13000 = 12740$ r/min therefore $n/n_o = 12740/4800 = 2.6$

Using the chart in fig.3 locate the point corresponding to bore diameter $d=25$ mm on the vertical line for radial ball bearings. Draw a straight- horizontal line to vertical line I. After that draw a straight-line from that point (A in example) to a point on the line II which corresponds to the n_o/n value (2.6 in example). Point C, where this line intersects vertical line indicates the lubrication interval 'h' which is approximately 4500 hours.

TABLE 7.5 GREASE VARIETIES AND CHARACTERISTICS :

CHARACTERISTICS	GREASE NAME				
	Lithium grease			Calcium grease (cup grease)	Sodium grease (fiber grease)
Thickener	Lithium Soap			Calcium Soap	Sodium Soap
Base Oil	Mineral oil	Synthetic oil (diester oil)	Synthetic oil (Silicon oil)	Mineral oil	Mineral oil
Dropping point (°c)	170 to 190	170 to 230	220 to 260	80 to 100	160 to 180
Operating temp. Range (°c)	-30 to +120	-50 to +130	-50 to +180	-10 to +70	0 to +110
Rotational range	Medium to high	High	Low to medium	Low to medium	Low to high
Mechanical stability	Excellent	Good to excellent	Good	Fair to good	Good to excellent
Water resistance	Good	Good	Good	Good	Bad
Pressure resistance	Good	Fair	Bad to fair	Fair	Good to excellent
Remarks	Most widely usable for various rolling bearings	Superior Low, Temperature & friction characteristics. Suitable for bearings for measuring instruments & extra small ball bearings for small electric motors.	Superior, High & low temperature characteristics.	Suitable for application at Low rotation speed & under light load. Not applicable at high temperature	Liable to emulsify in the presence of water. Used at relatively high temperature.

CHARACTERISTICS	GREASE NAME				
	Complex Base Grease		Non- Soap Base Grease		
Thickener	Lithium Complex Soap	Calcium Complex Soap	Bentone	Urea Compounds	Fluorine Compounds
Base Oil	Mineral Oil	Mineral Oil	Mineral Oil	Mineral Oil/Synthetic Oil	Synthetic Oil
Dropping point (°c)	250 or Higher	200 to 280	-	240 or higher	250 or Higher
Operating temp. Range (°c)	-30 to +150	-10 to +130	-10 to +150	-30 to +150	-40 to +250
Rotational range	Low to High	Low to Medium	Medium to High	Low to High	Low to Medium
Mechanical stability	Good to Excellent	Good	Good	Good to Excellent	Good
Water resistance	Good to Excellent	Good	Good	Good to Excellent	Good
Pressure resistance	Good	Good	Good	Good to Excellent	Good
Remarks	Superior mechanical stability and heat resistance. Used at relatively high temperature.	Superior pressure resistance when extreme pressure agents is added. Used In bearings for rolling mills.	Suitable for application at high temperature & under relatively heavy load	Superior water resistance, oxidation stability, and heat stability. Suitable for application at high temperature & high rotation speed.	Superior chemical resistance and solvent resistance. Usable upto 250 °C.

7.1.2 OIL LUBRICATION :

- † Oil lubrication is considered to be more effective than grease, provided proper sealing methods are employed to prevent the leakage.
- † Only highly refined oil should be used as bearing lubricant.

TYPES OF OILS

- † Natural oil
- † Synthetic oil
 - a) Diesters b) Silicon oil c) Fluorinated oil
 - d) Polyglycols e) Synthetic hydrocarbons
- † Animal & Vegetable oils

OIL IS PREFERRED - WHERE

- † Bearing speed is high
- † Operating temperature is considerably high
- † Dirt conditions are minimum
- † Sealing methods can be easily employed

TABLE 7.6 CHARACTERISTICS OF LUBRICATING OILS

TYPE OF LUBRICATING OIL	HIGHLY REFINED MINERAL OIL	MAJOR SYNTHETIC OILS				
		DIESTER OIL	SILICON OIL	POLYGLYCOLIC OIL	POLYPHENYL ETHER OIL	FLOURINATED OIL
Operating Temp. range (C°)	-40 to +150	-55 to +150	-70 to +350	-30 to +150	0 to +330	-20 to +300
Lubricity	Excellent	Excellent	Fair	Good	Good	Excellent
Oxidation stability	Good	Good	Fair	Fair	Excellent	Excellent
Radioactivity resistance	Bad	Bad	Bad to Fair	Bad	Excellent	-----
Suitability for High Loads	Very Good	Good	Poor	Very Good	Very Good	Good

With regard to operating temperature & lubrication, the following table lists the required oil viscosity for different types of rolling bearings.

Bearing Type	Dynamic Viscosity (mm ² /s)
Ball bearings, Cylindrical roller bearings, Needle roller bearings	13
Spherical roller bearings, Tapered roller bearings, Needle roller thrust bearing	20
Self-Aligning roller thrust bearings	30

Remarks : 1mm²/s = 1 cSt (Centistokes)

Amount of oil : When oil bath lubrication is used and a bearing mounted with its axis horizontal, oil should be added until the static oil level is at the center of the lowest bearing rolling element. For vertical shaft, add oil to cover 50% to 80% of the rolling element.

7.2 Methods of Oil Lubrication

7.2.1 Oil bath lubrication

This method of lubrication is one of the most popular for slow and intermediate speed operation. This is referred to as "oil bath lubrication", because the bearing operates in an oil bath made by filling the housing with oil. Too much oil causes excessive temperature rise (through agitation) while too little oil may cause bearing seizing. To assure proper lubrication it is sufficient that the oil level be kept around the center of bottom balls/ rollers of bearing in stationary condition. In the case of horizontal shaft, this level is determined when the bearing is idle. It is desirable to install an oil gauge so that the oil level can easily be checked when the bearing is idle. In the case of a vertical shaft, 50-80% of the ball / roller should be submerged when the bearing is idle. When more than two bearings are connected to a housing, the bearing running at the bottom will generate heat unless it rotates at extremely low speed. For such cases, we recommend the use of some other lubrication method.

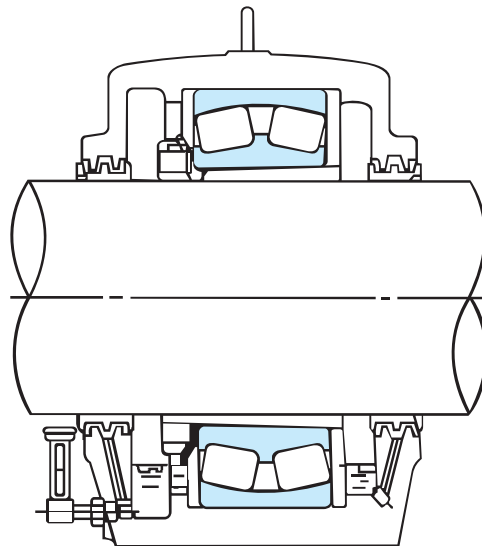

7.2.2 Splash lubrication

This is a lubrication method where, without direct submersion, oil is splashed by impellers attached to a shaft. This method is effective for fairly high speeds. One example, where splash lubrication is commonly used for bearings and gears is in a gear box where the gears may also be the splashing devices. In this case however, a shield plate should be installed or a magnet should be placed at the bottom of both to prevent worn grindings from the gears from possibly entering the bearings. Use of a conical rotating element in lieu of an impeller on a vertical shaft is effective in splashing oil, supplied by centrifugal force.

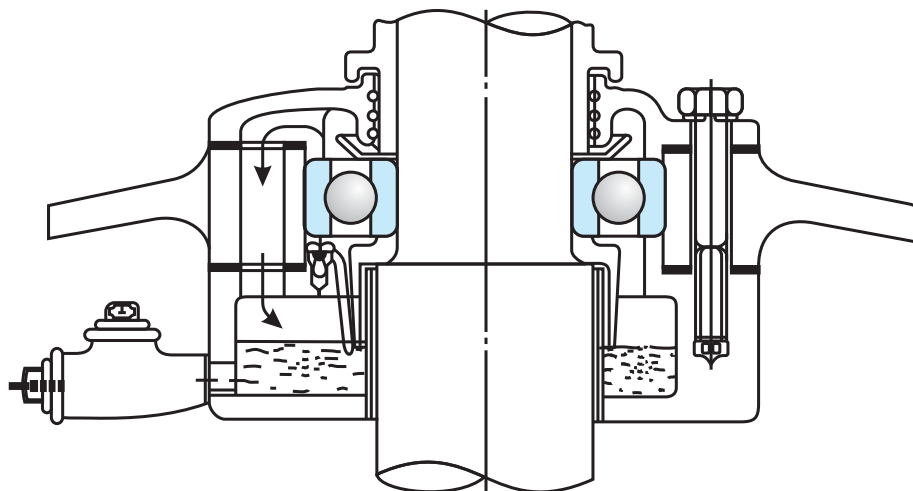

7.2.3 Drop-Feed lubrication

This is a lubrication method where an oil pot or oil reservoir (usually called an "oiler") is installed at the upper portion of housing and oil drips from the oiler through a tiny hole or from a wick (through capillary action). The dripping oil is converted to fog or mist on collisions with the rotating shaft / bearing parts. This method is more effective for comparatively high speeds and light loads rather than medium loads. Although application capability is great irrespective of shaft mounting (vertical or horizontal) remember to top off the oiler before it runs dry..

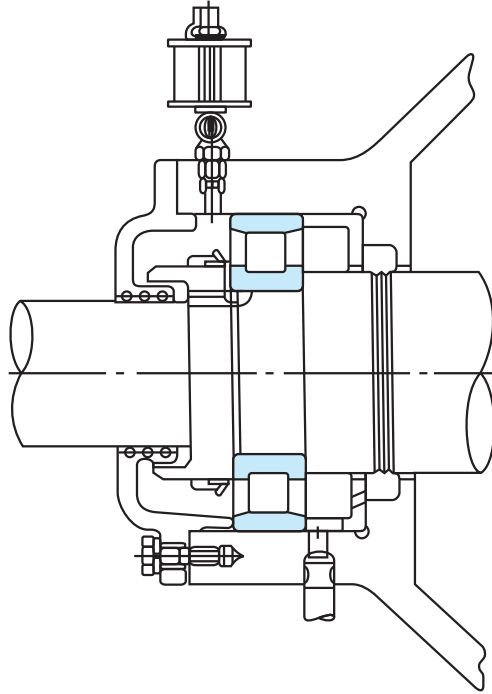

7.2.4 Circulating lubrication

- | Used for bearing cooling applications or for automatic oil supply systems in which the oil supply is centrally located.
- | One of the advantages of this method is that oil cooling devices and filters to maintain oil purity can be installed within the system.
- | In order for oil to thoroughly lubricate the bearing, oil inlets and outlets must be provided on opposite sides of the bearing.

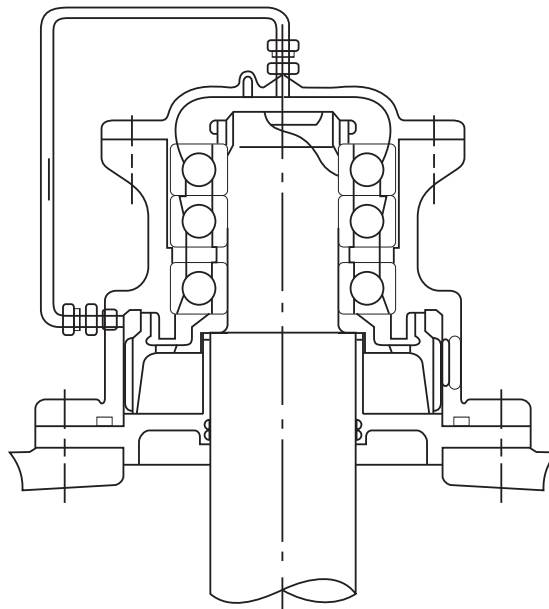

7.2.5 Disc Lubrication

In this method, a partially submerged disc rotates and pulls oil up into a reservoir from which it then drains down through the bearing, lubricating it.

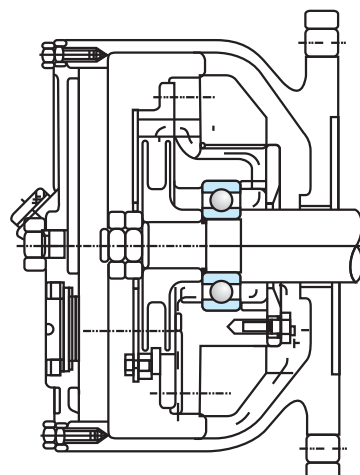

7.2.6 Spray lubrication (oil-mist lubrication)

Filtered oil is blown through a lubrication sprayer (using dry compressed air), emerging in an atomized form and is fed into the housing for lubrication. This lubrication method is called "spray lubrication" or "oil-mist lubrication", which features low resistance of oil, high effectiveness of cooling and prevention of bearings from dust or water invasion due to high internal pressure associated with new oil feeding at all times. This method has often been used for bearings with comparatively light loads such as high speed main spindle bearings or grinding machines though it recently has become popular for bearings mounted on metal rolling mills. In cases of metal rolling mills, oil atomizing by heating high viscosity oil causes the bearing to raise its temperature. Therefore, care should be taken when selecting the bearing clearance. Because of continuous clean bearing operation and less risk of oil leakage, use of this lubrication method is expanding.

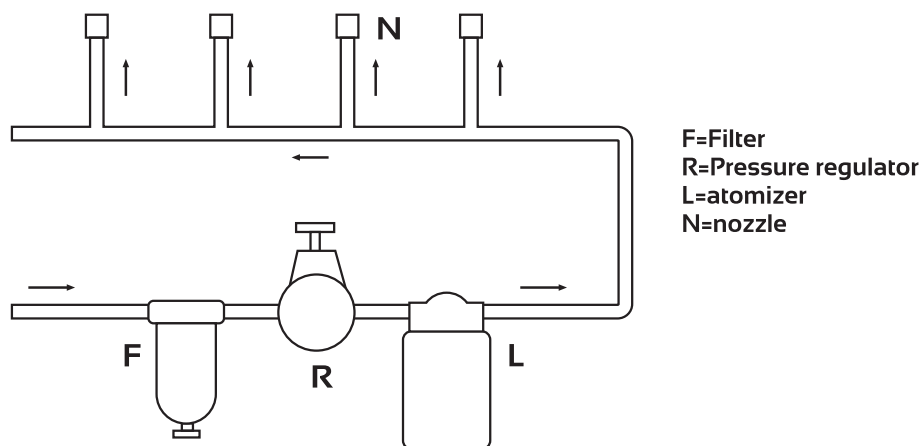

7.2.7 Oil Jet lubrication

- I This method lubricates by injecting oil under high pressure directly into the side of the bearing. This is a reliable system for high speed, high temperature or otherwise severe conditions.
- I Used for lubricating the bearings in jet engines, gas turbines and other high speed equipment.
- I Under-race lubrication for machine tools is one example of this type of lubrication

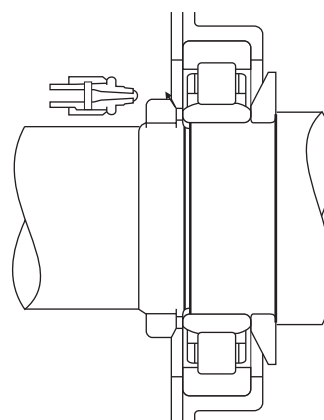

8. SEATINGS, LIMITS AND FITS

8.1 Seatings

Seatings for bearing rings must be parallel, circular and machined to their correct limits. Badly made seatings can distort thin section bearing rings, and thus reduce the efficiency and life of the bearings.

Shafts must be designed so that where rigid bearings are used, the slope at the bearings due to deflection is as small as possible. The permissible slope must vary with individual applications as it depends upon the operating conditions consequently limiting values are not listed. When experience is lacking on this point, our Technical Department will be pleased to give advice.

Housing must give adequate support to the outer ring of a bearing under load. If a housing distorts excessively, the outer ring will invariably distort as well, causing premature failure of the bearing. Where individual housing is used accurate alignment must be provided for rigid bearings.

Split housing should not be used unless absolutely necessary, since the joint between the cap and its base could distort the outer ring. If such housings are used, the two halves should be accurately doweled or registered before the bearing seating is machined. It is advisable to ensure that the cap can only be fitted one way round by suitably arranging the dowels or register.

Light alloy housings should be provided with substantial steel liners when:

- † A bearing has to work under wide variation of temperature, as differential expansion between the seating and bearing materials affects the initial fit between these members.
- † Heavy and/or shock loads are involved, for alloy seatings can quickly lose shape under such loading and give rise to serious trouble.
- † The steel liners must be an interference fit in their housings at the temperature extremes anticipated, and bearing seatings should be machined after the liners are fitted.
- † When light alloy or other non ferrous seating are to be used, we advise consultation with our Technical Department about the seating limits to be adopted.

Seating Fits

It is very important that bearing seatings be machined to their correct limits, incorrect fits can cause tightness within the bearing or allow one or both of the bearing rings to creep, and affect the running accuracy and the assembly and disassembly of a machine.

Creep is slow rotation of one ring relative to its seating. It is undesirable since the shaft and the bore of the bearing or the housing and the outside diameter of the bearing become worn. Creep is not due to friction within a bearing but is generally caused by radial loads rotating or oscillating with respect to a fixed point on the ring under consideration. The only satisfactory way of preventing creep under such conditions is to make the affected ring an interference fit on its seating. Set-screws or key ways should not be used in an effort to prevent creep, for they quickly wear due to constant chafing, or can distort bearing-rings, causing local overload and rapid bearing failure. Also, clamping a ring endways does not normally prevent creep.

Ball Journal, Roller Journal, Angular Contact and Duplex Bearings

Rotating Rings (usually inner ring) should be made interference fit on their seating to ensure that they will not creep.

Stationary Rings (usually outer ring) need not be interference fit provided there are no out-of-balance or oscillating loads.

Some bearing rings must slide endways on their seatings and in such cases a sliding fit is essential, although excessive slackness should be avoided. For example, where two or more Ball Journal bearings, or Roller Journal bearings with non detachable rings are mounted on the same unit, the unlocated ring or rings should be free to move endways, otherwise the bearings that are adjusted endwise should also be made sliding fits. Where the stationary ring of Ball Journal, Angular Contact or Duplex Bearing is held endways, it is common practice to make the ring a sliding fit. In the case of Roller Journal bearings a transition fit is normally used. For Journal bearings light interference fits, however, are not detrimental provided the correct diametral clearance is used, and the seating fit adopted may well be governed by considerations of mounting, dismounting, and of rigidity.

If a stationary ring does creep, out-of-balance loading or out-of-square mounting of one of the bearing rings must be suspected. Mounting errors should be corrected, and where out-of-balance loading exists the assembly should be dynamically balanced, static balancing not being enough. Where out-of-balance loading can't be reduced to a low level, or where it is a function of the machine, an interference fit must be used on the stationary ring as well as on the rotating ring. In a bearing arrangement where interference fits are used on all rings, a bearing layout must be used in which there is no danger of the bearings being axially nipped one against the other.

8.2 Fits

The necessity of a proper fit

In some cases improper fit may lead to damage and shorten bearing life. Therefore, it is necessary to make a careful analysis while selecting a proper fit.

Some of the negative conditions caused by improper fit are listed below:

- † Raceway cracking, early pitting and displacement of raceways
- † Raceway & shaft or housing abrasion caused by creeping in fretting corrosion
- † Seizing caused by loss of internal clearance
- † Increased noise & lowered rotational accuracy due to raceway groove deformation.

Selection of fits

Selection of proper fit depended upon thorough analysis of bearing operating conditions, including consideration of following factors:

(1) Condition of Rotation

Condition of rotation refer to the moving of bearing ring being considered in relation to the direction of load. There are 3 different conditions:

- † Rotating load
- † Stationery load
- † Direction of load indeterminate

(2) Magnitude of the load

The interference fit of a bearing's Inner ring on its seating will be loosened with the increasing load, as the ring will expand under the influence of rotating load, & ring may begin to creep. So, if it is of shock character, greater interference is required.

The loss of interference due to increasing load can be estimated using the following equation:

$$\Delta dp = 0.08 \sqrt{\frac{d}{B} Fr} \quad \text{Where } \Delta dp = \text{Interference decrease of inner ring}(\mu\text{m})$$

$d = \text{Bearing Bore (mm)}$

$$\Delta dp = 0.02 \left(\frac{Fr}{B} \right) \quad \begin{array}{l} B = \text{Inner Ring Width(mm)} \\ Fr = \text{Radial Load (N)} \\ C_{or} = \text{Basic Static Load (N)} \end{array}$$

(3) Bearing Internal Clearance

- † An interference fit of a bearing on the shaft or in housing means that ring is elastically deformed (expanded or compressed), and bearing's internal clearance reduced.
- † The internal clearance and permissible reduction depend on the type and size of the bearing.

- The reduction in clearance due to interference fit can be so large that bearings with an internal clearance which is greater than normal have to be used.
- The expansion of the inner ring and contraction of outer ring can be assumed to be approximately 60 - 80 % of the interference, depending on the material of shaft and housing.

(4) Temperature Condition

Interference between inner ring & steel shaft is reduced as a result of temperature increase (difference between bearing temperature and ambient temperature). This can result in an easing of fit of the inner ring on its seating, while outer ring expansion may result in increase in clearance.

The decrease of the interference of the inner ring due to this temperature difference may be calculated using following equation:

$$\Delta dt = 0.0015 * d * \Delta T$$

Where Δdt = Required effective interference for temperature difference μm

ΔT = Temperature difference between bearing temperature and ambient temperature $^{\circ}\text{C}$.

d = Bearing bore diameter mm.

(5) Running Accuracy Requirement

To reduce resilience and vibration, clearance fit should generally not be used for bearings, where high demands are placed on running accuracy.

(6) Design & Material of Shaft & Housing

The fit of a bearing ring on its seating must not lead to uneven distortion of the ring (out of roundness). This can be caused by discontinuity in the housing surface. Split housings are therefore not suitable where outer rings are to have an interference fit.

(7) Ease of Mounting & Dismounting

Bearings with clearance fit are usually easier to mount or dismount than those having interference fit. Where operating condition necessitate interference fit and it is essential that mounting & dismounting can be done easily, separable bearings or bearings with taper bore and adaptor or withdrawal sleeve may be used.

(8) Displacement of Non-Locating Bearings

If non-separable bearings are used as floating bearings, it is imperative that one of the bearing rings has to move axially during operation. This is ensured by adopting a clearance fit for that ring, which carries a stationary load, when the outer ring is under stationary load, so that axial displacement has to take place in the housing bore, a hardened intermediate bushing is often fitted to the outer ring.

(9) Effective Interference and finish of shaft & housing

Since the roughness of the fitted surface is reduced during fitting, the effective interference becomes less than the apparent interference. the amount of this interference decrease varies depending on roughness of the surfaces.

Normally, manufacturers assume the following interference reductions:

For ground shaft :1 Micron to 2.5 Micron

Machined Shaft : 5 Micron to 7 Micron

(10) Fitting Stress & Ring Expansion and Contraction

While calculating the minimum required amount of interference, following factors should be taken into consideration:

- ⊕ Interference is reduced by radial load
- ⊕ Interference is reduced by difference between bearing temperature and ambient temperature
- ⊕ Interference is reduced by variation of fitted surfaces

Important Details on Fits

- ⊕ Maximum interference should not exceed the ratio of 1:1000 of shaft or outside diameter.
- ⊕ Tight interference fits are recommended for :
 - (a) Operating conditions with large vibrations or shock loads
 - (b) Application using hollow shaft of housing with thin walls
 - (c) Application using housing made of light alloys or plastic.

Loose interferences are recommended for :

- (a) Application requiring high running accuracy
- (b) Application using small size bearings or thin walled bearings.

Shaft and housing material, geometry, hardness and surface finish must be carefully controlled. Ground shafts should be finished to 1.3 micron Ra or better ; for turned shafts, a finish of 2.5 micron Ra or better ; and housing bores should be finished to 4 micron Ra or better.

To avoid shearing of aluminium and magnesium housing during bearing installation, steel inserts should be used ; alternatively special lubricants may be used for freezing and heating to facilitate assembly. A minimum interference fit of 0.0015" and 0.001" per inch of diameter is required for magnesium and aluminium housing respectively.

Where bearings are to be pressed onto a hollow shaft, allowance must be made for contraction of the hollow shaft in order to maintain the desired radial pressure.

THE NEI PRODUCT ENGINEERING DEPARTMENT SHOULD BE CONSULTED FOR PROPER FITTING PRACTICE ON ALL SPECIAL APPLICATIONS.

Numeric value table of fitting for radial bearing of O class (Normal class) for metric size

TABLE 8.1 FITTING AGAINST SHAFT

Unit μm

Nominal bore diameter of bearing d (mm)		Δd_{mp}		g_5	g_6	h_5	h_6	j_5	js_5	j_6
Over	Incl.	high	low							
3	6	0	-8	4T - 9L	4T - 12L	8T - 5L	8T - 8L	11T - 2L	10.5T - 2.5L	14T - 2L
6	10	0	-8	3T - 11L	3T - 14L	8T - 9L	8T - 9L	12T - 2L	11T - 3L	15T - 2L
10	18	0	-8	2T - 14L	2T - 17L	8T - 8L	8T - 11L	13T - 3L	12T - 4L	16T - 3L
18	30	0	-10	3T - 16L	3T - 20L	10T - 9L	10T - 13L	15T - 4L	14.5T - 4.5L	19T - 4L
30	50	0	-12	3T - 20L	3T - 25L	12T - 11L	12T - 16L	18T - 5L	17.5T - 5.5L	23T - 5L
50	80	0	-15	5T - 23L	5T - 29L	15T - 13L	15T - 19L	21 - 7L	21.5T - 6.5L	27T - 7L
80	120	0	-20	8T - 27L	8T - 34L	20T - 15L	20T - 22L	26T - 9L	27.5T - 7.5L	33T - 9L
120	140									
140	160	0	-25	11T - 32L	11T - 39L	25T - 18L	25T - 25L	32T - 11L	34T - 9L	39T - 11L
160	180									
180	200									
200	225	0	-30	15T - 35L	15T - 44L	30T - 20L	30T - 29L	37T - 13L	40T - 10L	46T - 13L
225	250									
250	280									
280	315	0	-35	18T - 40L	18T - 49L	35T - 23L	35T - 32L	42T - 16L	46.5T - 11.5L	51T - 16L
315	355									
355	400	0	-40	22T - 43L	22T - 54L	40T - 25L	40T - 36L	47T - 18L	52.5T - 12.5L	58T - 18L
400	450									
450	500	0	-45	25T - 47L	25T - 60L	45T - 27L	45T - 40L	52T - 20L	58.5T - 13.5L	65T - 20L

TABLE 8.2 FITTING AGAINST HOUSING

Unit μm

Nominal outside diameter of bearing D (mm)		ΔD_{mp}		G_7	G_6	H_7	J_6	J_7	Js_7	K_6
Over	Incl.	high	low							
6	10	0	- 8	5L - 28L	0 - 17L	0 - 23L	4T - 13L	7T - 16L	7.5 - 15.5L	7T - 10L
10	18	0	- 8	6L - 32L	0 - 19L	0 - 26L	5T - 14L	8T - 18L	9T - 17L	9T - 10L
18	30	0	- 9	7L - 37L	0 - 22L	0 - 30L	5T - 17L	9T - 21L	10.5T - 19.5L	11T - 11L
30	50	0	- 11	9L - 45L	0 - 27L	0 - 36L	6T - 21L	11T - 25L	12.5T - 23.5L	13T - 14L
50	80	0	- 13	10L - 53L	0 - 32L	0 - 47L	6T - 26L	12T - 31L	15T - 28L	15T - 17L
80	120	0	- 15	12L - 62L	0 - 37L	0 - 50L	6T - 31L	13T - 37L	17.5T - 32.5L	18T - 19L
120	150	0	- 18	14L - 72L	0 - 43L	0 - 58L	7T - 36L	14T - 44L	20T - 38L	21T - 22L
150	180	0	- 25	14L - 79L	0 - 50L	0 - 65L	7T - 43L	14T - 51L	20T - 45L	21T - 29L
180	250	0	-30	15L - 91L	0 - 59L	0 - 76L	7T - 52L	16T - 60L	23T - 53L	24T - 35L
250	315	0	- 35	17L - 104	0 - 67L	0 - 87L	7T - 60L	16T - 71L	26T - 61L	27T - 40L
315	400	0	-40	18L - 115L	0 - 76L	0 - 97L	7T - 69L	18T - 79L	28.5T - 68.5L	29T - 47L
400	500	0	- 45	20L - 128L	0 - 85L	0 - 108L	7T - 78L	20T - 88L	31.5T - 76.5L	32T - 53L

Numeric value table of fitting for radial bearing of O class (Normal class) for metric size

TABLE 8.3 FITTING AGAINST SHAFT

Unit μm

Nominal bore diameter of bearing d (mm)		Δd_{mp}		js_6	k_5	k_6	m_5	m_6	n_6	p_6	r_6
Over	Incl.	high	low								
3	6	0	-8	12T - 4L	14T - 1T	17T - 1T	17T - 4T	20T - 4T	24T - 8T	28T - 12T	-
6	10	0	-8	12.5T - 4.5L	15T - 1T	18T - 1T	20T - 6T	23T - 6T	27T - 10T	32T - 15T	-
10	18	0	-8	13.5T - 5.5L	17T - 1T	20T - 1T	23T - 7T	26T - 7T	31T - 12T	37T - 18T	-
18	30	0	-10	16.5T - 6.5L	21T - 2T	25T - 2T	27T - 8T	31T - 8T	38T - 15T	45T - 22T	-
30	50	0	-12	20T - 8L	25T - 2T	30T - 2T	32T - 9T	37T - 9T	45T - 17T	54T - 26T	-
50	80	0	-15	24.5T - 9.5L	30T - 2T	36T - 2T	39T - 11T	45T - 11T	54T - 20T	66T - 32T	-
80	120	0	-20	31T - 11L	38T - 3T	45T - 3T	48T - 13T	55T - 13T	65T - 23T	79T - 37T	-
120	140										113T - 63T
140	160	0	-25	37.5T-12.5L	46T - 3T	53T - 3T	58T - 15T	65T - 15T	77T - 27T	93T - 43T	115T - 65T
160	180										118T - 68T
180	200										136T - 77T
200	225	0	-30	44.5T-14.5L	54T - 4T	63T - 4T	67T - 17T	76T - 17T	90T - 31T	109T - 50T	139T - 80T
225	250										143T - 84T
250	280										161T - 94T
280	315	0	-35	51T - 16L	62T - 4T	71T - 4T	78T - 20T	87T - 20T	101T - 34T	123T - 56T	165T - 98T
315	355										184T - 108T
355	400	0	-40	58T - 18L	69T - 4T	80T - 4T	86T - 21T	97T - 21T	113T - 37T	138T - 62T	190T - 114T
400	450										211T - 126T
450	500	0	-45	65T - 20T	77T - 5T	90T - 4T	95T - 23T	108T - 23T	125T - 40T	153T - 68T	217T - 132T

TABLE 8.4 FITTING AGAINST HOUSING

Unit μm

Nominal outside diameter of bearing D (mm)		ΔD_{mp}		K_7	M_7	N_7	P_7
Over	Incl.	high	low				
6	10	0	- 8	10T - 13L	15T - 8L	19T - 4L	24T - 1L
10	18	0	- 8	12T - 14L	18T - 8L	23T - 3L	29T - 3L
18	30	0	- 9	15T - 15L	21T - 9L	28T - 2L	35T - 5L
30	50	0	- 11	18T - 18L	25T - 11L	33T - 3L	42T - 6L
50	80	0	- 13	21T - 22L	30T - 13L	39T - 4L	52T - 8L
80	150	0	- 15	25T - 25L	35T - 15L	45T - 5L	59T - 9L
120	180	0	- 18	28T - 30L	40T - 18L	52T - 6L	68T - 10L
150	200	0	- 25	28T - 37L	40T - 25L	52T - 13L	68T - 3L
180	250	0	- 30	33T - 43L	46T - 30L	60T - 16L	79T - 3L
250	315	0	- 35	36T - 51L	52T - 35L	66T - 21L	88T - 1L
315	400	0	- 40	40T - 57L	57T - 40L	73T - 24L	98T - 1L
400	500	0	- 45	45T - 63L	63T - 45L	80T - 28L	108T - 0

8.3 Limits and Fits Guideline

TAPERED ROLLER BEARINGS

AFBMA RECOMMENDED FITTING PRACTICE

Shaft and housing material, geometry, hardness and surface finish must be carefully controlled. Ground shafts should be finished to 1.3 micron A.A. or better ; for turned shafts a finish of 2.5 µm A.A. or better ; and housing bores should be finished to 4 micron A.A. or better.

To avoid shearing aluminium and magnesium housing during bearing installation, steel inserts should be used ; alternatively special lubricants may be used for freezing and heating to facilitate assembly. A minimum interference fit is required for aluminium of 0.0010* per inch of diameter, for magnesium of 0.0015" per in of diameter.

Where bearings are to be pressed onto a hollow shaft, allowance must be made for contraction of the hollow shaft in order to maintain the desired radial pressure.

THE NEI PRODUCT ENGINEERING DEPARTMENT SHOULD BE CONSULTED FOR PROPER FITTING PRACTICE ON ALL SPECIAL APPLICATIONS.

AFBMA AUTOMOTIVE TAPERED CONE FITTING PRACTICE.

Use	Application	Fit Type	Cone Bore B*	Shaft Diameter B*	Fit	Cone Bore B*	Shaft Diameter B*	Fit
			Upto 3" bore			Above 3" bore		
Automotive Rotating Shafts	Pinion, transmission rear wheels, crossshaft, transfer case	Adjustable cones	+0.0005 -0.0000	+0.0005 +0.0000	0.0005T 0.0005L	+0.0010 -0.0000	+0.0015 +0.0005	0.0015T 0.0005L
		Non-Adjustable cones	+0.0005 -0.0000	+0.0015 +0.0010	0.0015T 0.0005T	+0.0010 -0.0000	+0.0025 +0.0015	0.0025T 0.0005T
	Differential	Non-Adjustable cones	+0.0005 -0.0000	+0.0025 +0.0015	0.0025T 0.0010T	+0.0010 -0.0000	+0.0035 +0.0025	0.0035T 0.0015T
Automotive Stationary Shafts	Front wheels, full floating rear wheels trailer wheels	Adjustable cones	+0.0005 -0.0000	-0.0002 -0.0007	0.0002L 0.0012L	+0.0010 -0.0000	-0.0002 -0.0012	0.0002L 0.0022L

AFBMA AUTOMOTIVE TAPERED CUP FITTING PRACTICE.

Use	Application	Fit Type	Cup O.D. D*	Housing Bore D*	Fit	Cup O.D. D*	Housing Bore D*	Fit	Cup O.D. D*	Housing Bore D*	Fit
			Less 3" O.D.			3" to 5" O.D.			Above 5" O.D.		
Auto-motive	Front wheels, full floating rear wheels pinion, differential	Non-Adjustable cups	+0.0010 -0.0000	-0.0015 -0.0005	0.0025T 0.0005T	+0.0010 -0.0000	-0.0020 -0.0010	0.0030T 0.0010T	+0.0010 -0.0000	-0.0030 -0.0010	0.0040T 0.0010T
		Differential	Non-Adjustable cups	+0.0010 -0.0000	+0.0010 +0.0020	0.0000L 0.0020L	+0.0010 -0.0000	+0.0010 +0.0020	0.0000L 0.0020L	+0.0010 -0.0000	-0.0000 +0.0020
	Rear wheels, transmission, cross shaft & other application	Adjustable cups	+0.0010 -0.0000	-0.0000 +0.0010	0.0010T 0.0010L	-0.0010 -0.0000	+0.0000 +0.0010	0.0010T 0.0010L	-0.0010 -0.0000	-0.0000 +0.0020	0.0010T -0.0020L

*D - Normal cup O.D., L - Loose, T - Tight

9. BEARING HANDLING

9.1 Mounting

Rolling bearing is a very precise product and its mounting deserves careful attention. The characteristics of this bearing should be thoroughly studied, and it should be mounted in the most appropriate manner. It is desired that the assembly of the bearing be fully studied in the design and assembly departments; and standards be established with regard to following items :

1. Cleaning the bearing and related parts.
2. Checking the dimensions and finishing the related parts
3. Mounting tools.
4. Mounting methods.
5. Checking after mounting.
6. Amount of lubricant.

Mounting should be conducted carefully in accordance with the specified standards. The rotating race (usually the inner) must be made of an interference fit on its seat to prevent "creep" or slow rotation of the race relative to the shaft or housing on or in which it is mounted. It is also advisable to clamp it firmly endways. The shoulders provided should be of ample proportions to ensure a true abutment for the race, but for standard roller bearings it should be relieved at about the diameter of the roller track. In case of bearings fitted with clamping sleeves and nuts it is necessary to see that these nuts are tightened to the fullest extent, and it is an advantage if the bearings are so fitted that the rotation of the shaft has a tendency to tighten the nut on the sleeve. The importance of rigidly fixing the race upon or in the revolving part cannot be too strongly emphasised.

The stationary race (usually the outer) should be a good fit in its housing perfectly free from shake. A standard roller bearing should be clamped endways to ensure that the roller's track is in centre of the race. Deep groove ball bearing if not locating the shaft, must be left free endways, having a clearance of approximately one-third the total width of the bearings. Angular contact bearings carry radial load and thrust load in one direction but to maintain the balls in correct contact with the tracks it is necessary for the thrust to be at least equal to the radial load. Where this is not inherent in the loading conditions another ball bearing must be fitted to provide the balance of the required thrust. This is automatically applied if the opposing bearing is adjusted to take up the end play. Care is necessary to ensure that over adjustment does not too heavily preload the bearings and in this connection allowance should be made for any difference in thermal expansion of shaft and housing.

Where there is no definite end thrust the shaft mounted on deep groove ball bearings may be located by clamping

endways the most lightly loaded bearings. With roller bearings, location may be effected by a bearing having lips in both races by plain faces, or by a ball locating bearing.

Set screws, keys or similar devices for fixing the races should be carefully avoided as they readily distort the rings and cause over loading of the balls or rollers.

Care should be taken to see that the shoulders between which the races are clamped are square with shaft.

Protection from dirt and moisture is most important.

PRACTICAL ADVICE

I. Storage

1. Store the bearings in a clean, dry place in their original wrappings. This will preserve them from deterioration.
2. Use older stock first.
3. Do not stack too many bearings on top of each otherwise the protective oil could be squeezed out from between the bearing and its wrapping, thus leading to corrosion problem.
4. Also, never store large bearings upright but lay them flat.

II. Fitting

1. Absolute cleanliness is essential when handling bearings. They should not be removed from their wrappings until required for fitting. A smooth metal-topped bench that can be wiped clean is a great advantage. All tools, shaft, housings and other components must be perfectly clean. If fitting operations are delayed or interrupted, the assembly should be wrapped with grease proof paper to exclude dirt and dust.

2. Bearing of about 11 inch outside diameter and large dia are protected by heavy mineral jelly. Thus must be removed before the bearings are used, and one method is to soak the bearing in clean, hot mineral oil at a temperature not exceeding 100°C.

3. All other bearing are usually coated with a rust preventative oil, unless prelubricated and/or packed to suit individual customer requirements. There is no need to remove this oil unless :

- i) It is sufficient to cause serious dilution of the oil or grease used in the bearing. This normally applies to smaller bearings where the rust preventive oil represents a large proportion of the required amount of lubricant.
- ii) Low torque is required.
- iii) A synthetic lubricant used that may not be compatible with the protecting oil.

To remove the rust preventive oil, wash the bearings in a good quality washing fluid ; white spirit or good quality paraffin is suitable.

Allow the bearings to drain thoroughly. Finally dry them, the following being satisfactory methods :

i) Place the bearings in an oven or on a hot plate, a temperature of 65-80°C should be adequate.

ii) Direct dry, clean, compressed air on the bearings. The cage and rings of smaller bearings must be held firmly otherwise a sudden blast of air would rapidly accelerate the free bearing parts, this could cause the balls to skid, thus damaging the highly finished internal surfaces of the bearing.

4. The fits of the rings on their seatings are very important Therefore ensure that the shaft and housing seatings are of correct size and of good shape.

5. All shoulders must be smooth and square with the axis of rotation.

6. Never drive one ring on its seating by blows on the other. Such blows would irretrievably damage the balls or rollers and raceways.

7. Apply pressure evenly around the rings. **"A press is better than a hammer."**

8. Should a hammer be used, mild steel or brass tube of suitable size, faced up square, should be interposed between it and the bearing. This will distribute the force of the blows (or rather taps), which should be given progressively around the ring.

9. When the parts or a separable roller bearings are brought together, the inner ring, the outer ring and the rollers must all be square one with the other. If not square, then the rollers would not slide freely, and force would have to be used to bring the parts together. Such force would result in the rollers and raceways becoming scored and this, in addition to causing noisy running could cause early failure of the bearing.

10. Where the ring of a bearing is against an abutment, make sure it is tight home.

11. For heavy interference fits, inner rings may be shrunk on to the seatings after heating in clean mineral oil at a temperature of approximately 100°C: Be sure that the bearing is in contact with the abutment shoulder after it has cooled.

12. In this case of taper clamping sleeve and nut bearings, the clamping nut must not be overtightened, for this could expand the inner ring and eliminate all clearance within the bearing, or even fracture the inner ring. We recommend that when using pin spanners, having a length of approximately five times the shaft diameter, one or two light hammer blows should be given to the handle of the spanner after the nut has been tightened as far as possible by hand pressure. This should tighten the nut just sufficiently. It is a good practice.

If possible, to check that the sleeve is still clamped firmly to the shaft after a few days running. As an additional precaution we recommend that whenever possible, the bearings are fitted so that the rotation of the shaft tends to tighten the nut on the sleeve. To assist customers who use torque spanners we recommend that the following torque be applied to the clamping nut for light series bearings.

Shaft Diameter	Torque on Nut
1" (25mm)	7.6 Kg.m
1.5" (38 mm)	12.4 Kg.m
2" (50 mm)	17.25 Kg.m
3" (75 mm)	30.3 Kg.m

For medium series bearing we recommend that the above figures be increased by approximately 50 percent.

9.1.1 Bearing Mounting Procedure

Any burrs, cutting chips, rust or dirt should first be removed from the bearing mounting surfaces. Installation then be simplified if the clean surfaces are lubricated with spindle oil.

Burrs, dirt, and other contaminants that infiltrate the bearing before and during mounting will cause noise and vibration and also in subsequent operation.

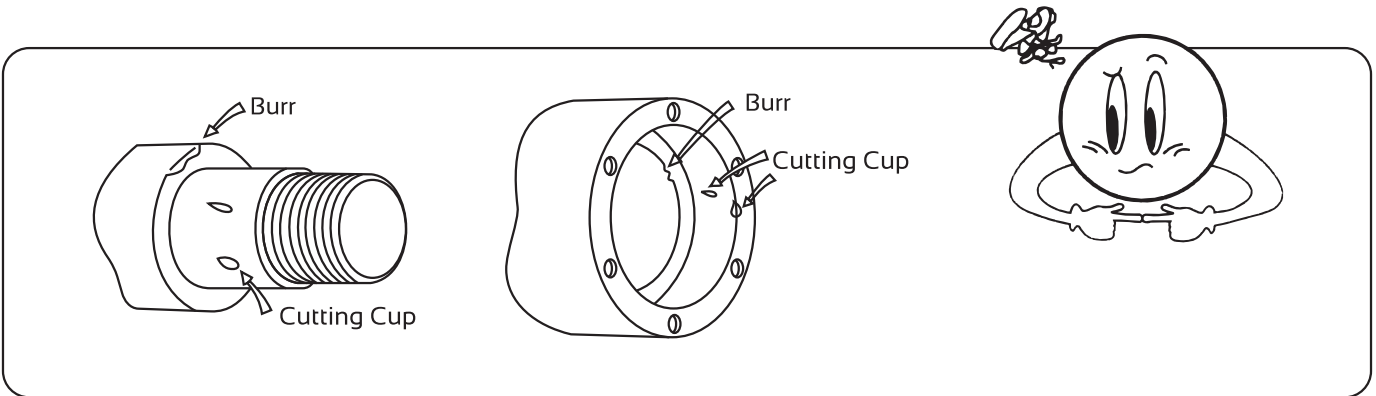

9.1.2 Preparation Procedure

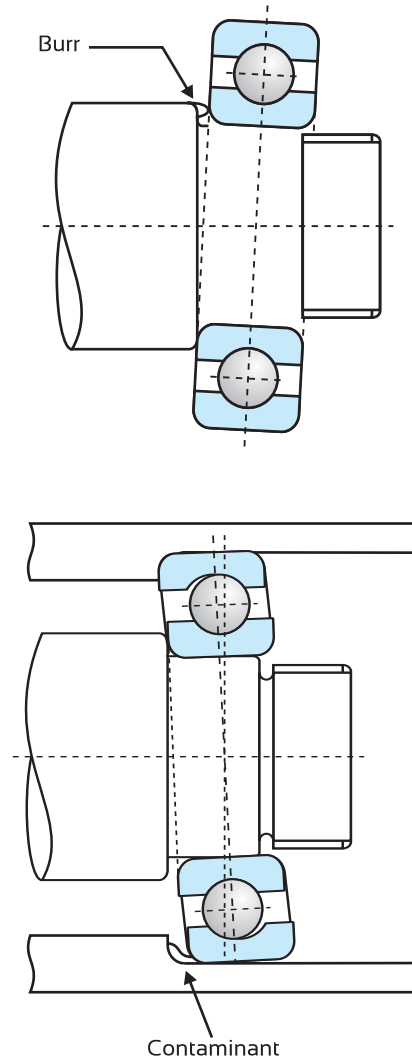
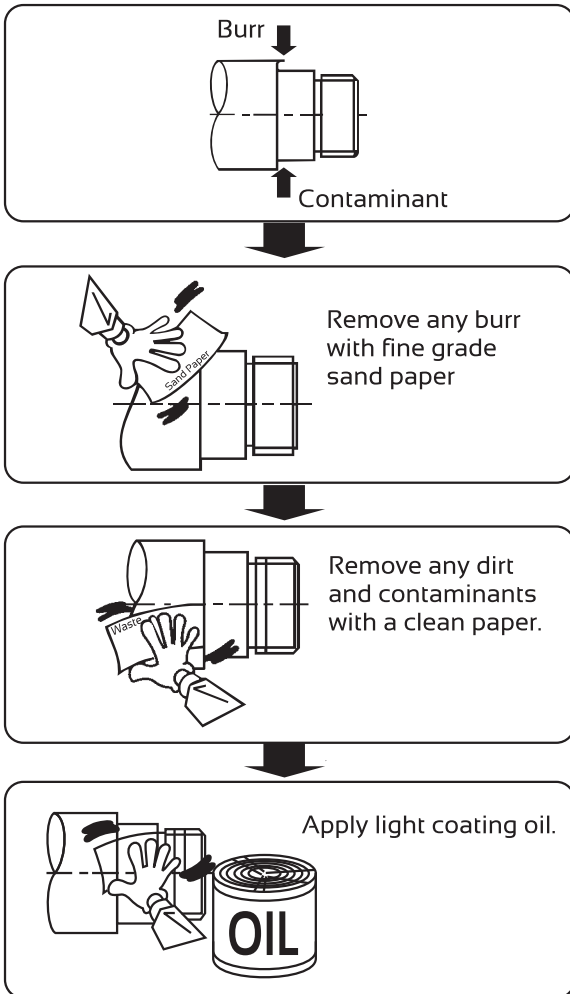

● Mounting Procedure

Pressing Surface

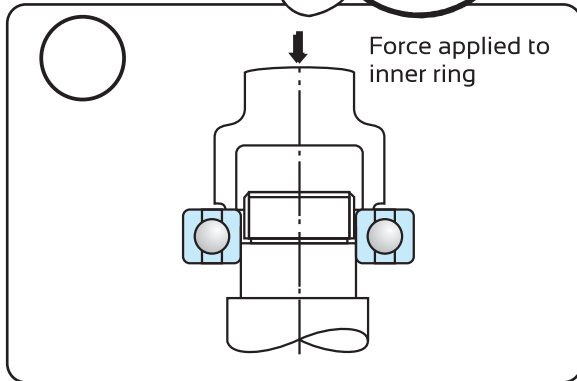
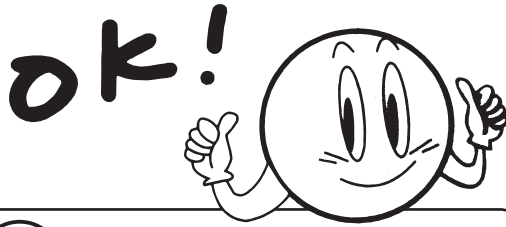

Surfaces with Zero pressing Load Tolerances

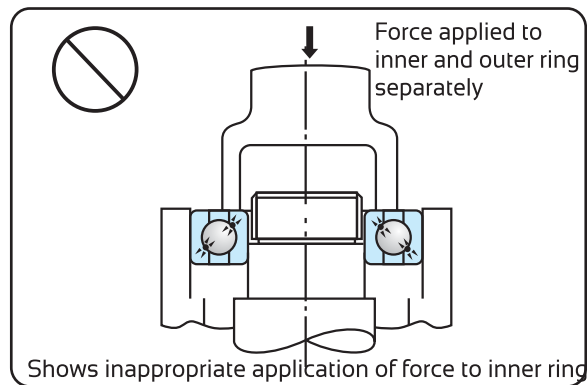
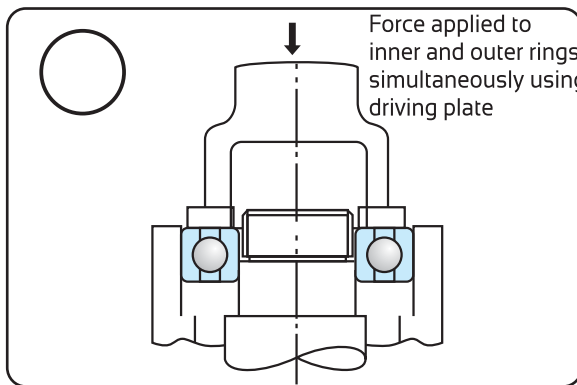
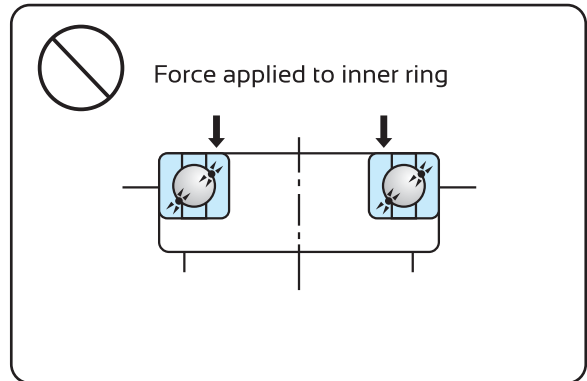
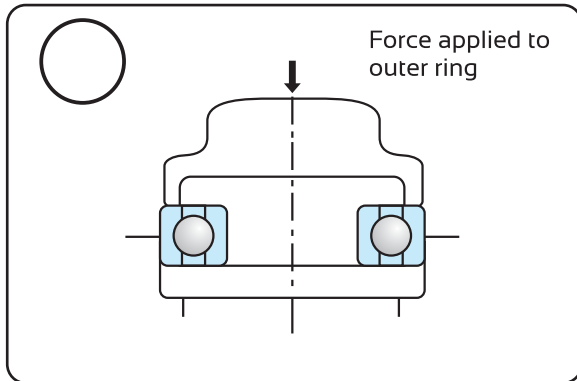
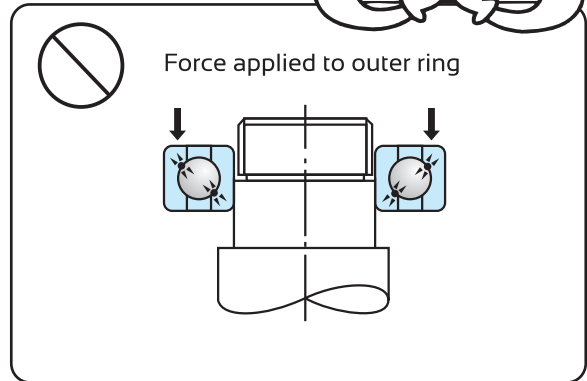

9.1.3 Temperature Mounting

(Heat expansion of inner ring to ease installation)

Commonly used for large bearings and bearings with a heavy interference fit.

1. Immersion of the bearing in heated oil is the most common method.
Use clean oil and suspend the bearing in the oil with a wire or support it underneath using a metal screen in order to avoid uneven heating of bearing elements.
2. The temperature to which the inner ring should be heated depends upon the amount of interference fit i.e. the diameter of the interference fit surfaces. Refer to the following graph to determine the proper temperature.
3. To prevent gaps from occurring between the inner ring and shaft shoulder, bearings which have been heated and mounted on the shaft should be held in place until they have cooled completely.

Observe these precautions when heating bearings

1. bearings should never be heated over 120°C.
2. This temperature mounting method cannot be used for pre-greased and sealed bearings or shielded bearings.

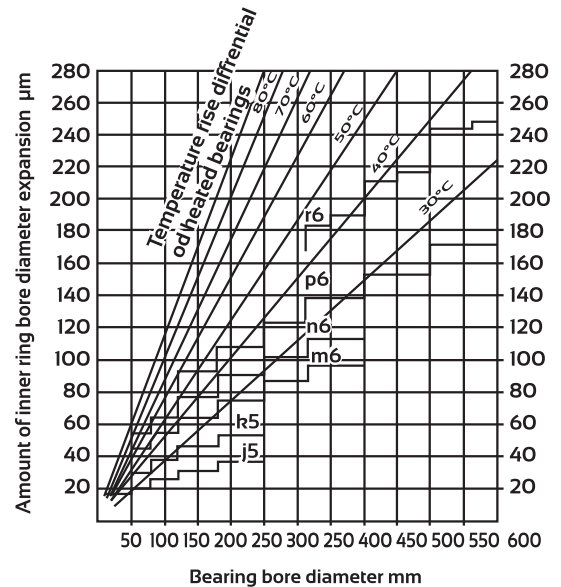
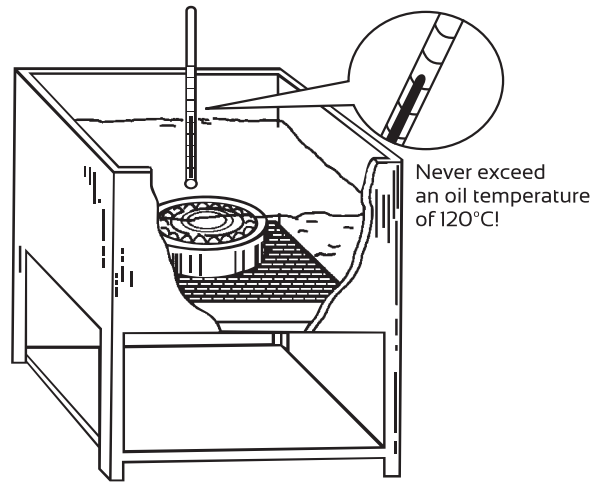
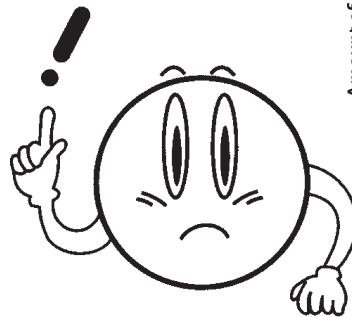
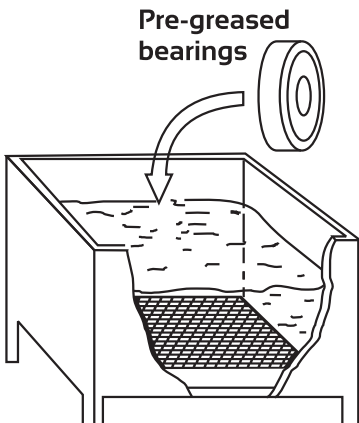

Other heating methods

1. **Bearing Oven**
Bearings are dry. This method can also be used for pre-greased bearings. Do not heat the bearings above 120°C.
2. **Induction Heating**
This method can also be used for the inner rings of cylindrical roller bearings. Bearings are dry and can be heated up in a short period of time. After using this method, administer a demagnetizing treatment to the bearing.

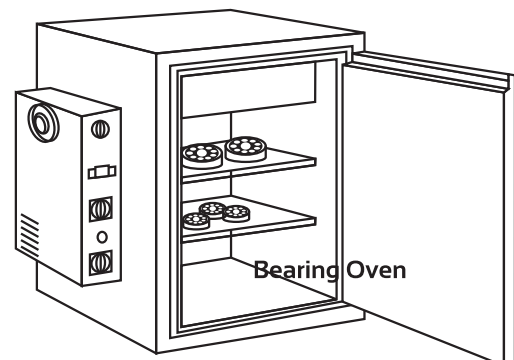

9.2 Dismounting & Replacement

1. Unnecessary removal of a bearing should be avoided, particularly where interference fits have been used. Removal can damage the bearing and in some instances, cause deterioration of the interference fit. Very often it is sufficient to clean and relubricate the bearing in its fitted position. Remove a bearing if you need to inspect it closely. Symptoms that guide are the condition of the lubricant, the bearing temperature and the noise level.

2. With Roller bearings there is sometimes a Ball location bearing. This may be only a push fit on the shaft, and therefore, facilitates easy dismantling.

3. In certain applications some form of extractor may be necessary. This may act directly on the ring to be removed. Never try to remove the inner ring by applying force on the outer ring or vice versa.

4. Thrust bearings need offer no difficulty as push fits should have been used, but take care to keep the rings square or they will bend.

5. Worn shafts, housings and abutments must have attention if creep has occurred. Knurling, scoring or distortion of the seating on which creep has occurred must not be resorted to simulate an interference fit. Such deceptive practices are ineffective, for creep will very often return all too quickly. Also, even if the ring is prevented from creeping it will usually be distorted by the seating, with bearing failure resulting from local overloading of the raceways and of the balls or rollers.

6. When ordering replacements, be sure to give the symbols marked on each of the rings of the bearing if any doubt exists as to the correct bearing number. If a housing or seating ring etc. is supplied with the bearing, please also quote the marking on it. This is especially important for thrust bearings with housings or seating rings, and for externally aligning bearings. It is necessary to ensure that the correct radial clearance is mentioned for ball and roller bearings being ordered.

● BEARING REMOVAL TOOLS & PROCEDURE

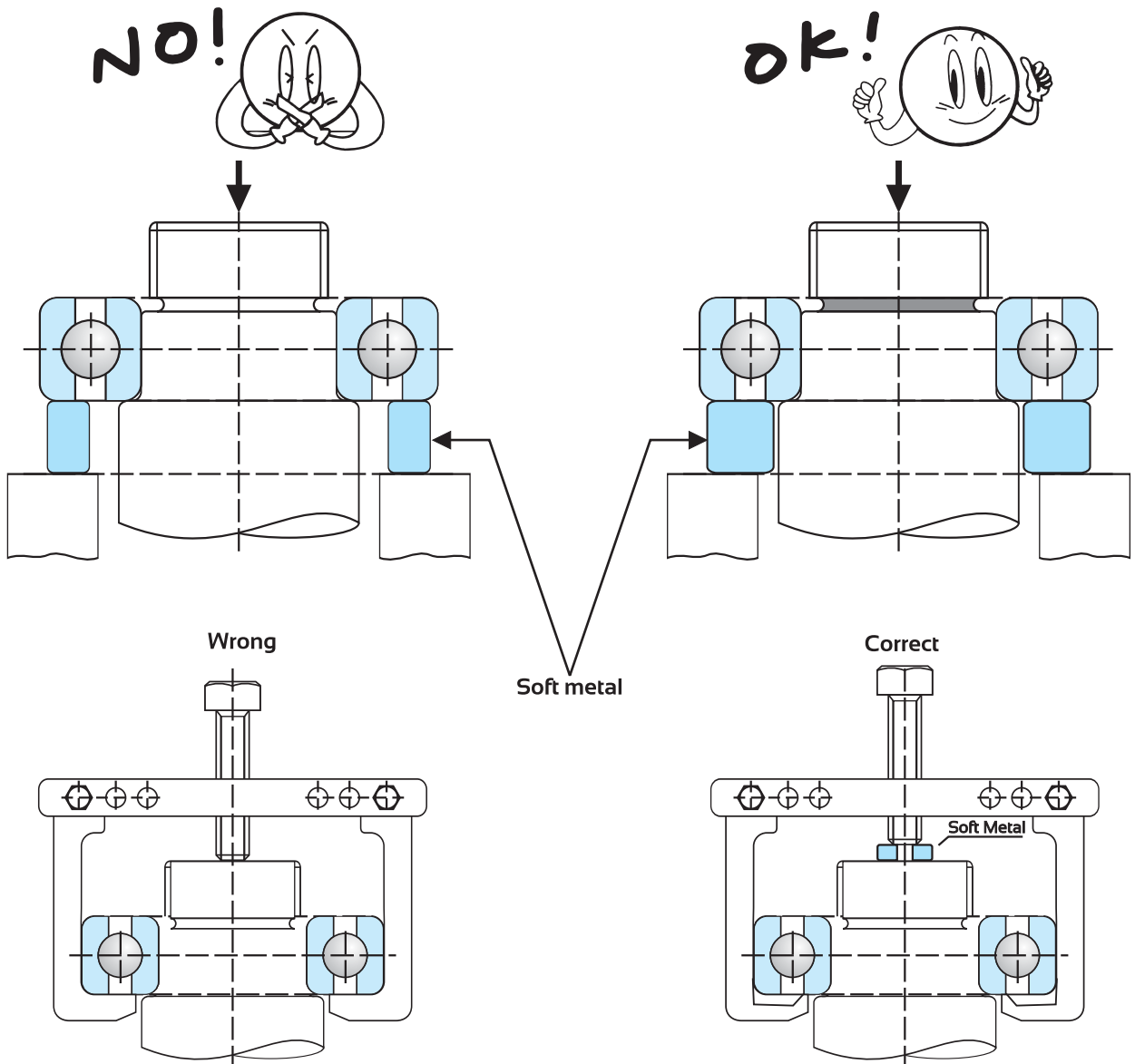
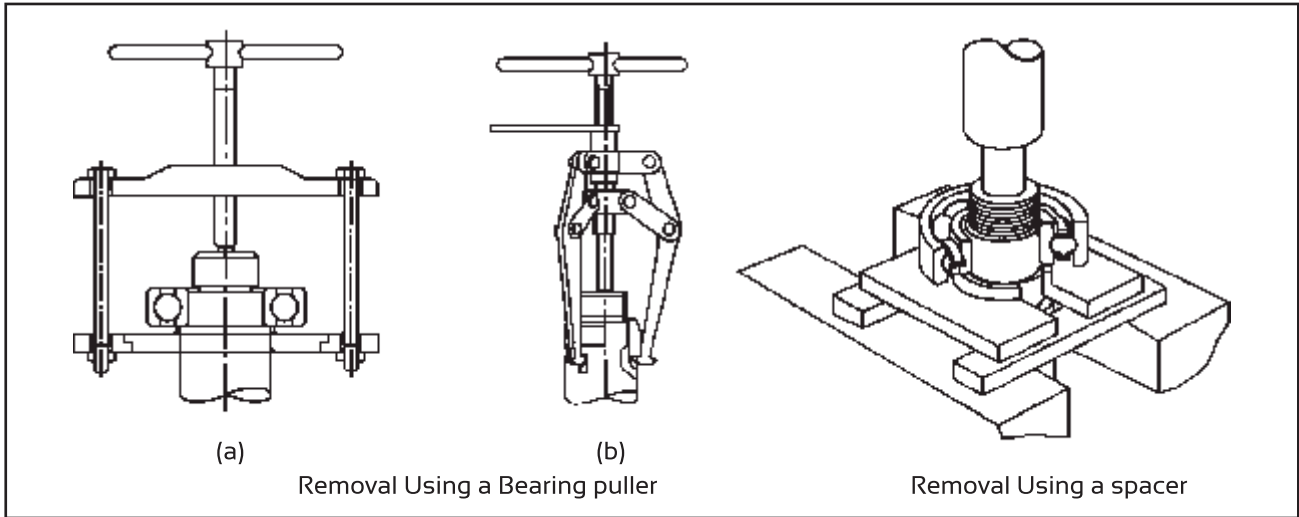

9.3 Bearing Cleaning

It is seldom necessary to clean bearings with the sole object of removing the rust preventive oil, which they are coated before being packed. Rust preventives with a petroleum jelly base have certain lubrication qualities and in any case since the amount used for the protection of bearings is small, no harm is done with the grease or oil used for lubrication.

As a rule washing shall only be resorted to when bearings have become dirty or when the mechanism in which they are used is so sensitive that even slight irregular resistance to rotation is not permissible. Cleaning media most commonly employed for used bearing are :

(a) Benzene, (b) White Spirit (Low flash point), (c) Turpentine, (d) Paraffin Oil, (e) Light Spindle Oil, (f) Trichloro Ethylene, (g) Carbon Tetra Chloride; (h) Petroleum Ether

▮ METHOD OF CLEANING

Rough cleaning

In Rough Cleaning a separate container should be used and to support the bearing a screen should be provided. All the cleaning media as mentioned above can be used for cleaning bearing, if bearing is very dirty, Gasoline should be used. Care should be taken to prevent igniting and to prevent rusting after cleaning.

In rough cleaning, each bearing is moved about vigorously without rotating it, since any trapped foreign matter can scratch the rolling elements & tracks. If the oil is heated it cleans the bearing effectively. However, never heat the oil above 100°C. After as much as possible of the dirt has been removed this way, the bearing is transferred to the final cleaning.

Final cleaning

Now bearing is submerged in clean oil & rotated gently the inner ring or outer ring so that inside of the bearing will also be cleaned. After that, rotate the bearing faster until all trace of dirt has been removed. Now remove the bearing from bath and wipe it with a clean cloth, apply a coat of rust preventive oil to the bearing and wrap it is not going to be used immediately. It is necessary to always keep rinsing oil clean.

After any cleaning process it is necessary to protect the bearing by dipping it in hot petroleum jelly or oil, or by applying the grease to be used that it reaches every part of the surface. In the latter case rotation of bearings is necessary while grease is being applied.

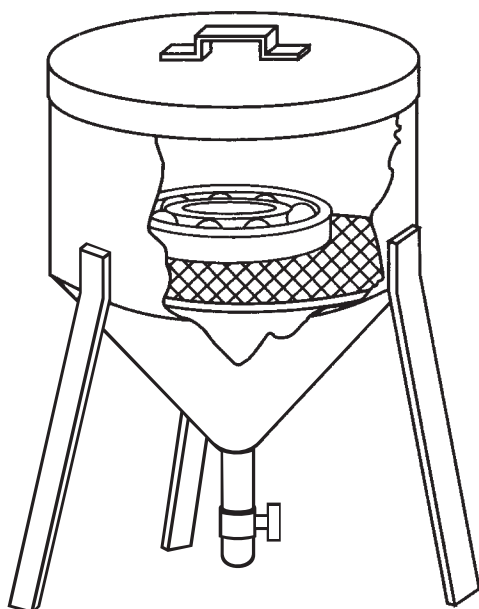

Rough cleaning

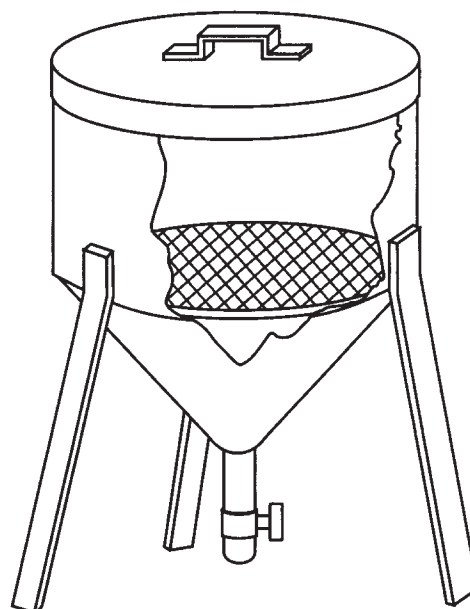

Final cleaning

9.4 Abutments for Bearings

1. Shaft and housing abutments for a ball or roller bearing must be flat and square with the axis of rotation.
2. An abutment must be deep enough to clear the unground corner radius of a bearing ring and contact its ground face.
3. The radius at the root of an abutment must be smaller than the corner radius of the ring located against that abutment, alternatively the root may be undercut.
4. The edge of an abutment must be reduced or chamfered, as a burred edge can so easily dent or distort a bearing ring.

Ball Journal, Angular Contact and Duplex Bearings

When a bearing carries heavy axial load, abutments must be deeper i.e. they should not extend beyond the inner ring outside diameter or below the outer ring bore. A deep abutment can cause difficulties when a bearing is removed from its seating and, therefore, it is advantageous to provide grooves or holes on such an abutment so that a suitable extraction tool can be used.

Roller Journal Bearings

Bearings not carrying axial loads or taking location duty

The maximum abutment depth is more important ring for these bearings than for ball bearings, and maximum inner abutment diameter and minimum outer ring abutment diameter are recommended accordingly. Broadly these coincide with the diameter of the inner and outer ring raceways respectively.

Bearings carrying axial loads and taking location duty

Abutments for these bearings should extend beyond the raceways to avoid shear stresses in the lips. Every possible care is necessary to ensure that the abutments are flat and square with the axis of rotation.

Thrust Bearings

Abutments for Thrust bearings should extend beyond the pitch circle diameter of the balls to prevent the washers dishing under load.

For standard Thrust bearings with one small bore washer and one large bore washer, the approximate pitch circle diameter

$$= \frac{\text{Small bore diameter} + \text{Large outside diameter}}{2}$$

In case of bearings with two bore washers, use the pitch circle diameter for the same basic bearing size with one large bore washer and one small bore washer as above

10. BEARING FAILURE

10.1 Why Bearings Fail

In general, if rolling bearings are used correctly they will survive to their predicted fatigue life. However, they often fail prematurely due to avoidable mistakes. Failure of the rolling bearing can occur for a variety of reasons. Accurate determination of the cause of a bearing failure is must to make suitable recommendations for eliminating the cause.

The major factors that singly or in combination may lead to premature failure during service include incorrect mounting, excessive loading, excessive preloading, inadequate & insufficient lubrication, impact loading, vibrations, contamination, entry of harmful liquids.

It is difficult to determine the root cause of some of the premature failures. If all the conditions at the time of failure, and prior to the time of failure are known, including the application, operating conditions and environment, then by studying the nature of failure and its probable causes, the possibility of similar future failures can be reduced.

Two or more failure pattern can occur simultaneously and can thus be in competition with one another to reduce the bearing life. Also a pattern of failure that is active for one period in the life of a bearing can lead to or can even be followed by another failure mechanism, which then cause premature failure. Thus in some instances, a single failure pattern will be visible and in other indications of several failure pattern will be evident, making exact determination of root cause difficult. So when more than one bearing failure pattern has been occurred, proper analysis depends on careful examination of failed components. In contrast to fatigue life, this premature failure could be caused by :

- (1) IMPROPER MOUNTING
- (2) IMPROPER HANDLING
- (3) POOR LUBRICATION,
- (4) CONTAMINATION
- (5) EXCESSIVE HEATING
- (6) EXCESSIVE LOAD

CAUSES OF OPERATING IRREGULARITIES IN A BEARING :

When certain irregularities are observed in a bearing, causes mentioned below should be checked and suitable corrective measures should be taken.

(A) Noise:

Possible causes are :

- (1) Contact of rotating parts
- (2) Faulty mounting
- (3) Insufficient / inadequate lubricant
- (4) Abnormal load
- (5) Improper internal clearance
- (6) Sliding of rolling element
- (7) Presence of contamination
- (8) Corrosion
- (9) Occurrence of flaking on raceways / rolling elements.
- (10) Brinelling due to careless handling.

(B) Abnormal Temperature :

Possible causes are :

1. Friction in bearing due to contact of rolling parts & seals.
2. Excessive amount of lubricant
3. Insufficient lubricant
4. Improper lubricant
5. Incorrect mounting
6. Excessive load on bearing

(C) VIBRATION :

Possible causes are :

1. Occurrence of brinelling, flaking
2. Incorrect mounting
3. Existence of foreign objects

10.2 Bearing Damage and Corrective Measures

DESCRIPTION

CAUSES

COUNTER MEASURES

1. FLAKING



- * Abnormal excessive load
- * Deflection or misalignment of shaft
- * Poor Lubrication
- * Ingress of foreign objects

- * Correct accuracy of shaft & housing
- * Improve mounting & alignment
- * Review quantity & type of lubricant
- * Carefully clean & handle shaft and housing



- * Non uniform distribution of lubricant
- * Etching

- * Uniform distribution of grease
- * Review the mounting procedure
- * Improve operating conditions



- * Excessive preload

- * Correct the amount of preload
- * Use torque wrench to achieve correct preload



- * Excessive Axial load
- * Inadequate lubrication
- * Contamination

- * Review application conditions.
- * Review quantity & type of lubricant
- * Carefully clean & handle shaft and housing

2. PEELING



- * Foreign Matter
- * Improper Lubrication

- * Review type of lubricant & lubrication method
- * Improve sealing efficiency

DESCRIPTION

CAUSES

COUNTER MEASURES

3. SEIZURE

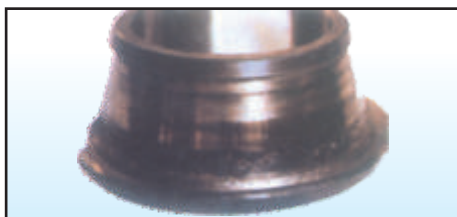

- * Loss of clearance
- * Insufficient lubrication
- * Excessive load
- * Roller Skew

- * Review fitting & bearing clearance
- * Select a proper lubricant & feed it in proper quantity
- * Prevent misalignment
- * Improve method of mounting

4. DISCOLOURATION



- * Ingress of foreign objects
- * Poor lubrication
- * Temper colour by overheating
- * Deposition of Deteriorated oil on surface

- * Oil deposition should be removed by wiping with suitable solvent
- * Select a proper lubricant & feed it in proper quantity

5. FRETTING CORROSION



- * Minute clearance on fit surface
- * Slight sliding during operation as a result reduced interference under a load
- * Swing with smaller amplitude
- * Vibration during transportation

- * Fix shaft & housing
- * Increase interference
- * Apply oil
- * Change lubricant
- * Use oil or high consistency grease when used for oscillation motion

6. DAMAGED RETAINERS



- * Excessive load
- * Impact load
- * Improper lubrication
- * Excessive vibration
- * Ingress of foreign objects

- * Select a proper lubricant & feed it in proper quantity
- * Review of application conditions
- * Investigate shaft and housing rigidity
- * Correct the method of mounting & handling

DESCRIPTION

CAUSES

COUNTER MEASURES

7. CRACKING



- * Excessive impact load
- * Excessive load
- * Excessive interference fit
- * Bearing seat has larger corner radius than bearing
- * Slipping of balls due to poor lubrication
- * Excessive clearance during operation

- * Re-evaluate load conditions
- * Check fits & bearing clearance
- * Improve the rigidity of shaft & housing
- * Correct the method of mounting & handling

8. SMEARING



- * Insufficient lubrication
- * Ingress of foreign objects
- * Jamming of rolling elements in cage pockets
- * Improper mounting
- * Angular movement of shaft while bearings are stationary under load
- * Excessive slippage of the rolling elements
- * Excess axial load

- * Select a proper lubricant, quantity & method
- * Review the load conditions
- * Improve the sealing
- * Correct mounting faults
- * Clean the shaft & housing
- * Setting of a suitable preload

9. EXCESSIVE WEAR



- * Coarse/Fine matter in the bearing & acts as lapping agents
- * Insufficient lubrication
- * Rotational creep due to loose fit
- * Skewing of Rollers
- * Inner or outer ring out of square

- * Improve sealing
- * Check lubricant type & amount
- * Check shaft & housing
- * Correct mounting faults

10. CREEPING



- * Insufficient interference in the mating parts
- * Insufficient sleeve tightening
- * Insufficient surface pressure

- * Review the fits
- * Review the usage conditions
- * Redesign for greater rigidity

DESCRIPTION

CAUSES

COUNTER MEASURES

11. CHIPPING

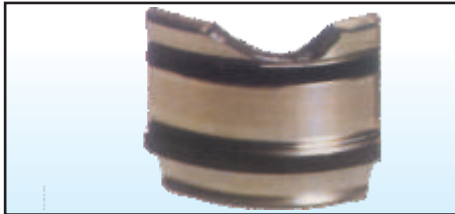

- * Impact of excessive load
- * Poor handling
- * Ingress of solid objects

- * Improve handling
- * Improve sealing
- * Review application conditions

12. RUST & CORROSION



- * Improper storage, cleaning
- * Poor packaging
- * Insufficient rust inhibitor
- * Poor rust prevention
- * Chemical action of lubricant
- * Penetration by water, acid etc.

- * Improve storage & handling
- * Improve sealing
- * Periodically inspect the lubricating oil
- * Take care when handling the bearing

13. ELECTRICAL PITTING

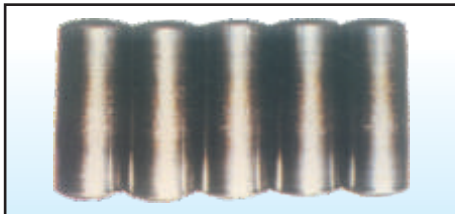

- * Continuous passage of electric current
- * Intermittent passage of electric current

- * Create a bypass circuit for the current
- * Insulate the bearing so that current does not pass through it.

14. ROLLERS SKEWING



- * Deformation or tilt of bearing ring due to poor accuracy of shaft or housing
- * Poor rigidity of shaft or housing
- * Deflection of shaft due to excessive clearance

- * Improvement in machining accuracy of shaft and housing
- * Improvement in rigidity of shaft and housing.
- * Employment of adequate clearance

11. BEARING TABLES

● SINGLE ROW RADIAL BALL BEARING (Metric Series)

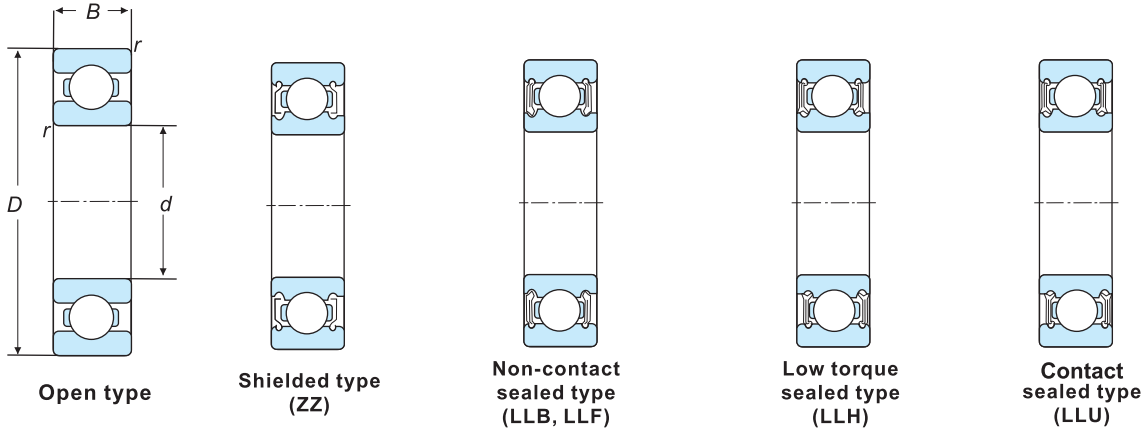

Boundry Dimensions					Load Rating				Limiting Speed (rpm)		Bearing Numbers
mm					Dynamic KN	Static	Dynamic Kgf	Static	Grese	Oil	
d	D	B _{IR}	B _{OR}	r _{smin}	C _r	C _{or}	C _r	C _{or}			Open Type
10	26	8	8	0.3	4.55	1.96	464	200	29000	34000	6000
	30	9	9	0.6	5.98	2.64	610	269	25000	30000	6200
	35	11	11	0.3	6.78	3.32	691	338	23000	27000	6300
12	24	6	6	0.3	2.89	1.46	295	149	27000	32000	6901
	28	8	8	0.3	5.1	2.39	520	244	26000	30000	6001
	32	10	10	0.6	6.9	3.1	703	316	22000	26000	6201
	32	14	14	0.6	6.2	2.7	633	276	22000	26000	62201
	37	12	12	1	9.7	4.2	989	428	20000	24000	6301
15	40	12	12	1	11.4	5	1162	510	18000	21000	613963
	28	7	7	0.3	4.1	2.06	418	210	24000	28000	6902
	32	9	9	0.3	5.6	2.84	571	290	22000	26000	6002
	32	8	8	0.3	5.6	2.84	571	290	22000	26000	16002
	35	11	11	0.6	7.75	3.6	790	367	19000	23000	6202
	35	14	14	0.6	7.7	3.7	786	378	22000	25000	62202
	35	11	11	0.6	7.64	3.72	779	379	24000	27000	6202C
16	42	13	13	1	11.4	5.54	1162	556	17000	21000	6302
	42	13	13	1	9.6	4.55	979	464	17000	21000	BB1002
17	30	7	7	0.3	4.65	2.58	474	263	20000	24000	6903
	35	8	8	0.3	6.8	3.35	693	341	20000	24000	16003
	35	10	10	0.3	6.8	3.35	693	341	20000	24000	6003
	40	12	12	0.6	9.6	4.6	979	469	18000	21000	6203
	40	12	12	0.6	10.5	5.2	1071	530	18000	21000	6203C
	40	16	16	0.6	9.6	4.6	979	469	16000	18000	62203
	42	12	12	0.6	11.6	5.7	1182	581	18000	21000	6203A/42
18	47	14	14	1	13.5	6.55	1376	668	16000	19000	6303
	56	16	16	1.1	20.7	10.4	2112	1061	13000	15000	63/18
20	32	9	9	0.3	4	2.47	408	252	21000	23000	6904/32
	37	9	9	0.3	6.4	3.7	652	377	18000	20000	6904
	42	8	8	0.3	7.4	4	754	408	16000	18000	16004
	42	9	9	0.6	8.65	4.5	882	459	15000	18000	98204
	42	12	12	0.6	9.4	5.05	955	515	18000	21000	6004
	47	14	14	1	13.7	6.7	1397	683	16000	18000	6204
	47	14	14	1	12.8	6.5	1306	663	16000	18000	6204M
	47	16	16	1	13.7	6.7	1397	683	16000	18000	6204/2B
	47	15.88	15.88	0.6	13.7	6.7	1397	683	16000	18000	BB1003
	47	18	18	1	12.8	6.7	1306	684	11000	16000	62204
20	50	14	14	1	13.7	6.7	1397	683	16000	18000	1838002
	52	15	15	1.1	15.9	7.85	1621	800	14000	17000	6304

● SINGLE ROW RADIAL BALL BEARING (Metric Series)

Equivalent bearing load dynamic

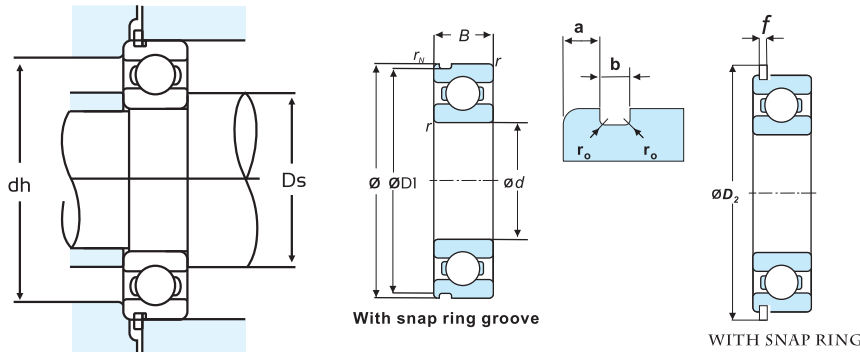

$$P_r = XF_r + YF_a$$

F_a	e	$\frac{F_a}{F_r} < e$		$\frac{F_a}{F_r} > e$	
		X	Y	X	Y
C_{or}					
0.010	0.18				2.46
0.020	0.20				2.14
0.040	0.24				1.83
0.070	0.27				1.61
0.10	0.29	1	0	0.56	1.48
0.15	0.32				1.35
0.20	0.35				1.25
0.30	0.38				1.13
0.40	0.41				1.05
0.50	0.44				1.00

Static

$$P_{or} = 0.6Fr + 0.5Fa$$

when $P_{or} < Fr$ use $P_{or} = Fr$

Bearing Numbers												Mass Kg	
Open Type	Shield Type		Non Contact	Low torque type	Contact type		TMB	TS2	TS3	ASTB	Snap Ring Groove	Snap Ring	(Approx.)
6000	Z	ZZ	-	-	RS	RSS	-	TS2	-	-	-	-	0.019
6200	Z	ZZ	-	-	RS	RSS	-	-	-	-	N	NR	0.032
6300	Z	ZZ	-	-	LU	-	-	-	-	-	-	-	0.053
6901	-	-	-	-	RS	RSS	-	-	-	-	-	-	0.011
6001	Z	ZZ	-	-	LUAX2	-	-	-	-	-	-	-	0.021
6201	Z	ZZ	-	LH	RS/LUAX2 / LU	RSS/RSSA1	TM	TS2	TS3	-	NI	NR	0.038
62201	Z	-	-	-	-	RSS	-	-	-	-	-	-	0.05
6301	Z	ZZ	-	-	LU	LLU	-	-	-	-	-	-	0.061
613963	-	-	-	-	-	-	-	-	-	-	-	-	0.072
6902	Z	-	-	-	-	RSS	-	-	-	-	-	-	0.018
6002	Z	ZZ	-	LLH	LU	LLU	TMB	-	-	-	-	-	0.035
16002	-	-	-	-	-	-	-	-	-	-	-	-	0.025
6202	Z	ZZ	-	-	LU	LLU/LLVA	TMB	-	-	-	-	-	0.052
62202	-	-	-	-	-	RSS	-	-	-	-	-	-	0.06
6202C	-	-	-	-	-	LLWA	-	-	-	-	-	-	0.044
6302	Z	ZZ	-	-	RS	RSS	-	-	-	-	-	-	0.084
BB1002	-	-	-	-	-	-	-	-	-	-	-	-	0.084
6903	-	-	-	-	-	-	-	-	-	-	-	-	0.016
16003	-	-	-	-	-	-	-	-	-	-	-	-	0.032
6003	Z	ZZ	-	LLHA	LU	LLU	-	-	-	-	-	-	0.039
6203	Z	ZZ	-	LLHA	LU	LLU	TMB	-	-	-	-	-	0.065
6203C	-	-	-	LLHA	LU	LLVA	TM	TS2	-	-	NI	-	0.061
62203	-	-	-	-	-	RSS	-	-	-	-	-	-	0.09
6203A/42	-	-	-	-	LU	-	TMB	-	-	-	-	-	0.078
6303	Z	ZZ	-	LLHA	LU	LLU / LLWA/LLVA	-	TS2	-	-	-	-	0.116
63/18	-	-	-	-	-	LLU	-	-	-	AST	-	-	0.196
6904/32	-	-	-	LLH	-	-	-	-	-	-	-	-	0.026
6904	-	-	-	-	-	-	-	-	-	-	-	-	0.036
16004	-	-	-	-	-	-	-	-	-	-	-	-	0.049
98204	-	-	-	-	-	-	-	-	-	-	-	-	0.052
6004	Z	ZZ	-	LH	LU	LLU	-	-	-	AST	-	-	0.069
6204	Z	ZZ	-	LLHA	LU	LLU / RSS	TM/TMB	-	-	AST	N	-	0.114
6204M	-	-	-	-	-	-	-	-	-	-	N	-	0.105
6204/2B	-	ZZ	-	LLHA	-	-	TM	-	-	-	-	-	0.11
BB1003	-	-	-	-	-	-	-	-	-	-	-	-	0.12
62204	-	-	-	-	-	-	-	-	-	-	-	-	0.14
1838002	-	-	-	-	-	-	-	-	-	-	-	-	0.125
6304	Z	ZZ	-	-	RS	RSS	TMB	-	-	AST	N	-	0.147

● SINGLE ROW RADIAL BALL BEARING (Metric Series)

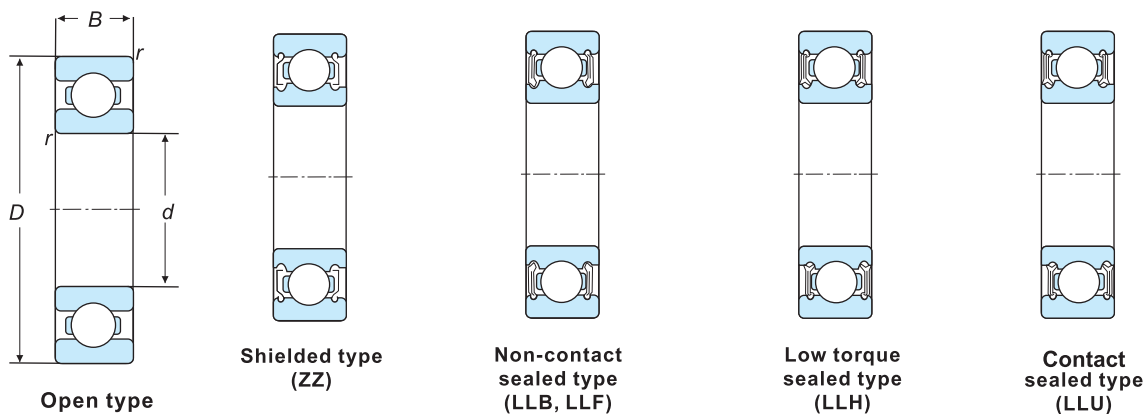

Boundary Dimensions					Load Rating				Limiting Speed (rpm)		Bearing Numbers
mm					Dynamic KN	Static	Dynamic Kgf	Static	Grese	Oil	
d	D	B _{IR}	B _{OR}	r _{smin}	C _r	C _{or}	C _r	C _{or}			Open Type
20	52	15	15	1.1	18.1	9	1846	918	18000	20000	6304M
	55	11	11	1.1	15.9	7.85	1621	800	14000	17500	20x55x11
	56	17	17	1.1	20.5	10.2	2091	1040	13000	15000	20x56x17
	62	16	16	1	23.4	12.2	2385	1244	10000	12000	BB1063
22	50	14	14	1	12.9	6.8	1316	694	14000	17000	62/22
	52	15	15	1	15.9	7.85	1621	800	19000	21000	6304/22
	52	15	15	1	18.15	9.03	1850	921	18000	20000	6304/22M
25	56	16	16	1.1	20.7	10.4	2109	1060	13000	15000	63/22
	42	9	9	0.3	7.05	4.55	719	464	16000	19000	6905
	47	8	8	0.3	8.35	5.1	851	520	15000	18000	16005
	47	12	12	0.6	10	5.85	1019	596	15000	18000	6005
	52	9	9	0.6	11.6	6.5	1182	663	14000	17000	98205
	52	15	15	1	14	7.85	1427	800	13000	15000	6205
	52	18	18	1	14.1	7.8	1439	796	9000	15000	62205
	52	12	12	0.6	15.2	18.05	1551	1842	9000	15000	420205
	52	15	15	1	17.6	9.3	1795	948	17000	19000	6205C
	56	15	15	1.1	17.7	9.505	1805	969	16000	18000	25X56X15
	62	12	12	0.6	19.5	11.3	1988	1152	13500	16000	1838001
	62	17	17	1.1	21.2	10.9	2161	1111	12000	14000	6305
25.5	62	14	14	0.2	16	10.3	1631	1050	6700	11400	6007/25
	62	17	17	1.5	23.6	12.1	2407	1234	16000	18000	6305CS
	68	12	12	0.6	20.4	11.1	2080	1132	14000	15000	NI287
	72	17	17	1.1	21.2	10.9	2161	1111	12000	14000	SP72X25X17
	72	19	19	2	27.1	14.5	2762	1478	7700	13100	6306/25
	72	19	19	1.1	27.1	14.5	2762	1478	10000	12000	872489
	58	16	16	1	17.9	9.75	1825	994	12000	14000	62/28
	68	18	18	1.1	26.7	14	2722	1427	11000	13000	63/28
28	68	17	17	1.1	26.7	14	2723	1428	11000	13000	SP63/28
	72	18	18	1.5	25.7	15.4	2620	1570	9800	11000	72x28x18
	72	18	18		22.2	14.6	2263	1488	9800	11000	BB1087
30	47	9	9	0.3	7.1	4.9	724	500	14000	17000	6906
	55	13	13	1	13.2	8.3	1346	846	13000	15000	6006
	55	11	11	1	13.2	8.3	1346	846	13000	15000	SP6006
	55	9	9	0.3	11.2	7.35	1142	749	13000	15000	16006
	62	16	16	1	19.5	11.3	1988	1152	11000	13000	6206
	62	20	20	1	19.5	11.3	1990	1153	7500	13000	62206
	62	14	14	1	20.6	11.3	2102	1153	7500	13000	420206
72	19	19	1.1	27.1	14.5	2762	1478	10000	12000	6306	

● SINGLE ROW RADIAL BALL BEARING (Metric Series)

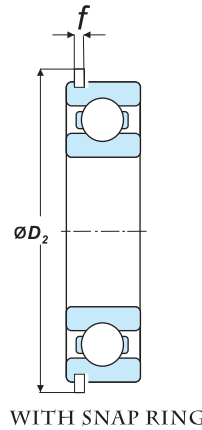
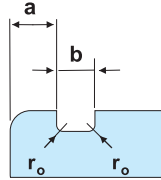
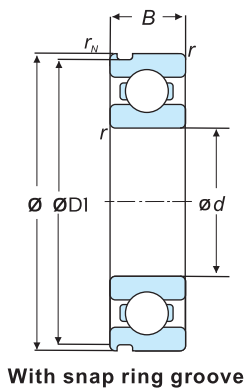

Equivalent bearing load
dynamic

$$P_r = XF_r + YF_a$$

F_a	e	$\frac{F_a}{F_r} < e$		$\frac{F_a}{F_r} > e$	
		X	Y	X	Y
C_{or}					
0.010	0.18				2.46
0.020	0.20				2.14
0.040	0.24				1.83
0.070	0.27				1.61
0.10	0.29	1	0	0.56	1.48
0.15	0.32				1.35
0.20	0.35				1.25
0.30	0.38				1.13
0.40	0.41				1.05
0.50	0.44				1.00

Static

$$P_{or} = 0.6Fr + 0.5Fa$$

when $P_{or} < Fr$ use $P_{or} = Fr$

Bearing Numbers												Mass Kg
Open Type	Shield Type	Non Contact	Low torque type	Contact type		TMB	TS2	TS3	ASTB	Snap Ring Groove	Snap Ring	(Approx.)
6304M	-	-	-	-	-	-	-	-	AST	-	-	0.142
20x55x11	-	-	-	-	-	-	-	-	-	-	-	0.136
20x56x17	-	-	-	-	-	-	TS2	-	-	N	-	0.190
BB1063	-	ZZ	-	-	-	-	-	-	-	-	-	0.254
62/22	-	-	-	-	-	-	-	-	-	-	-	0.12
6304/22	-	-	-	-	-	TMB	-	-	-	-	-	0.13
6304/22M	-	-	-	-	-	TMB	TS2	-	AST	-	-	0.141
63/22	-	-	-	-	-	TM	-	-	AST	-	-	0.164
6905	-	-	-	-	-	-	-	-	-	-	-	0.042
16005	-	-	-	-	-	-	-	-	-	-	-	0.06
6005	Z	ZZ	-	LLH	-	RSS	TMB	-	-	N	NR	0.088
98205	-	-	-	-	-	-	-	-	-	-	-	0.085
6205	Z	ZZ	-	-	LU	LLU/LLUA	TMB	-	-	N	NR	0.129
62205	-	-	-	-	-	-	-	-	-	-	-	0.16
420205	-	-	-	-	-	-	-	-	-	-	-	0.1
6205C	Z	-	-	-	-	LLUA/LLU	-	-	AST	N	-	0.128
25X56X15	Z	-	-	-	-	-	-	-	-	-	-	0.162
1838001	-	-	-	-	-	-	-	-	-	-	-	0.176
6305	Z	ZZ	-	-	LU	LLU	TMB	-	-	N	NR	0.225
6007/25	-	-	-	-	-	-	-	-	-	-	-	0.211
6305CS	-	-	-	-	-	LLU/LLUA	-	-	AST	NX	-	0.225
NI287	-	-	-	-	-	-	-	-	AST	-	-	0.234
SP72X25X17	-	-	-	-	-	-	-	-	-	-	-	0.37
6306/25	-	-	-	-	-	LLU	TM	-	-	N	-	0.365
872489	-	-	-	-	-	-	-	-	-	-	-	0.363
62/28	-	-	-	LLH/LLHA	-	LLU	TM/	-	-	N	NR	0.171
63/28	-	-	-	-	-	LLU	TMB	-	-	N	-	0.293
SP63/28	-	-	-	-	-	-	-	-	-	-	-	0.254
72x28x18	-	-	-	-	-	-	-	-	-	-	-	0.35
BB1087	-	-	-	-	-	-	TMB	-	-	-	-	0.36
6906	-	-	-	-	-	-	-	-	-	-	-	0.05
6006	Z	ZZ	LBRA	LLHA	LU	LLU	-	-	-	N	NR	0.116
SP6006	-	-	-	-	-	-	-	-	-	-	-	0.1
16006	-	-	-	-	-	-	-	-	-	-	-	0.091
6206	Z	ZZ	-	LLH	RS	RSS	TM/TMB	-	-	N	NR	0.201
62206	-	-	-	-	-	-	-	-	-	-	-	0.25
420206	-	-	-	-	-	-	-	-	-	-	-	0.18
6306	Z	ZZ	LBRA	LLH	LU	-	TM	-	-	N	NR	0.334

● SINGLE ROW RADIAL BALL BEARING (Metric Series)

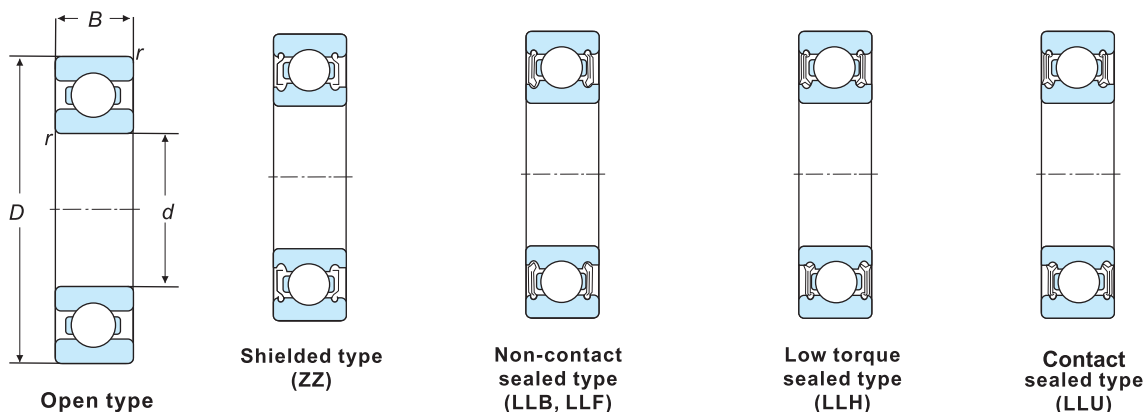

Boundary Dimensions					Load Rating				Limiting Speed (rpm)		Bearing Numbers
mm					Dynamic KN	Static	Dynamic Kgf	Static	Grese	Oil	
d	D	B _{IR}	B _{OR}	r _{smin}	C _r	C _{or}	C _r	C _{or}			Open Type
30	72	19	19	1.1	32.57	17.28	3321	1762	14000	15000	6306C
	72	17	17	1.1	29.7	16.7	3029	1703	12000	14000	420306
	72	21	21	1.1	32.57	17.28	3321	1762	15000	16000	NI345
	90	23	23	1.5	40.6	22.8	4139	2324	7800	9200	6406
35	62	9	9	0.3	11.7	8.2	1193	836	12000	14000	16007
	62	14	14	0.5	16	10.3	1631	1050	12000	14000	6007
	62	14	14	0.5	16	10.3	1631	1050	12000	14000	6007SPL
	72	17	17	1.1	25.7	15.3	2620	1560	9800	11000	6207
	72	17	17	1.5	25.7	15.3	2620	1560	9800	11000	6207RO
	72	23	23	1.1	25.5	15.2	2602	1551	6300	11000	62207
	80	21	21	1.5	33.4	19.2	3405	1957	8800	10000	6307
	80	26	21	1.5	33.4	19.2	3405	1957	8800	10000	SP6307
40	80	21	21	1.5	33.4	19.2	3406	1958	8800	10000	CR-6307
	100	25	25	1.5	48.3	27.8	4924	2834	7800	9100	6407
	58	12	12	0.6	10.29	7.91	1049	807	11000	13000	NI305
	62	12	12	0.6	13.7	10	1397	1020	10000	12000	6908
	68	9	9	0.3	11.1	8.55	1131	871	10000	12000	16008
	68	15	15	1	16.8	11.5	1713	1172	10000	12000	6008
	80	18	18	1.1	29.1	18	2966	1835	8700	10000	6208
	80	18	18	1.1	29.1	18	2966	1835	8700	10000	6208K
	85	18	18	1.1	29.1	18	2967	1835	11000	12000	40X85X18
	90	23	23	1.5	40.6	22.9	4139	2324	7800	9200	6308
	90	23	23	1.5	44.3	26	4520	2653	7900	10000	6308C
	90	23	23	1.5	40.6	22.9	4139	2324	7800	9200	6308RO
45	90	23	23	1.5	51	28	5201	2855	11000	13000	NI334
	110	27	27	2.0	61.9	38	6310	3274	7000	8200	6408
	75	16	16	1	21	15.1	2141	1539	9200	11000	6009
	75	12	12	1	21	15.1	2141	1539	9200	11000	SP6009
	85	19	19	1.1	32.7	20.5	3333	2090	7800	9200	6209
	85	19	19	1.1	32.7	20.5	3333	2090	7800	9200	6209K
50	100	25	25	1.5	53	32	5403	3262	7000	8200	6309
	120	29	29	1.1	71.5	44.4	7238	4526	6300	7400	6409
	80	10	10	0.6	13.2	11.3	1346	1152	8400	9800	16010
	80	16	16	1	21.8	16.6	2222	1692	8400	9800	6010
	90	20	20	1.1	35	23.2	3568	2365	7100	8300	6210
	90	20	20	1.1	35	23.2	3568	2365	7100	8300	6210K
	110	27	27	2	61.9	38	6310	3874	6400	7500	6310
130	31	31	2.1	92.28	55.13	9416	5626	5700	6700	6410	

● SINGLE ROW RADIAL BALL BEARING (Metric Series)

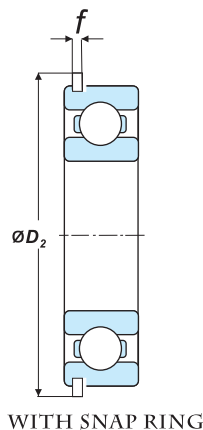
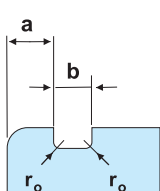
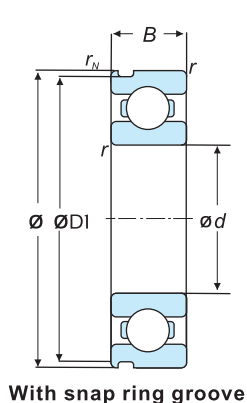

Equivalent bearing load
dynamic

$$P_r = XF_r + YF_a$$

F_a	e	$\frac{F_a}{F_r} < e$		$\frac{F_a}{F_r} > e$	
		X	Y	X	Y
C_{or}					
0.010	0.18				2.46
0.020	0.20				2.14
0.040	0.24				1.83
0.070	0.27				1.61
0.10	0.29	1	0	0.56	1.48
0.15	0.32				1.35
0.20	0.35				1.25
0.30	0.38				1.13
0.40	0.41				1.05
0.50	0.44				1.00

Static

$$P_{or} = 0.6Fr + 0.5Fa$$

when $P_{or} < Fr$ use $P_{or} = Fr$

Bearing Numbers												Mass Kg	
Open Type	Shield Type	Non Contact	Low torque type	Contact type		TMB	TS2	TS3	ASTB	Snap Ring Groove	Snap Ring	(Approx.)	
6306C	-	-	-	-	-	TM	-	-	-	-	-	0.331	
420306	-	-	-	-	-	-	-	-	-	-	-	0.3	
NI345	-	-	-	-	LLU	-	-	-	AST	N	-	0.35	
6406	-	-	-	-	-	-	-	-	-	N	NR	0.698	
16007	-	-	-	-	-	-	-	-	-	-	-	0.11	
6007	Z	ZZ	-	-	RS	RSS	TMB	-	-	N	NR	0.154	
6007SPL	-	-	-	-	-	RSS	-	-	-	-	-	0.154	
6207	Z	ZZ	-	-	LU	LLU	TMB	-	-	ASTB	N	NR	0.28
6207RO	-	-	-	-	-	-	-	-	-	-	-	0.286	
62207	-	-	-	-	-	-	-	-	-	-	-	0.39	
6307	Z	ZZ	-	LLHA	LU	LLU	TMB	TS2	-	AST	N	NR	0.457
SP6307	-	-	-	-	-	LLU	-	-	-	-	-	0.483	
CR-6307	-	-	-	-	-	LLU	-	-	-	ASTB	-	-	0.445
6407	-	-	-	-	-	-	-	-	-	-	-	0.925	
NI305	-	-	-	-	-	-	-	-	-	-	-	0.084	
6908	-	-	-	-	-	-	-	-	-	-	-	0.11	
16008	-	-	-	-	-	-	-	-	-	-	-	0.13	
6008	-	ZZ	-	-	-	LLU	-	-	-	N	NR	0.195	
6208	Z	ZZ	-	LLHA	LU	LLU	TM/TMB	-	-	N	NR	0.357	
6208K	-	-	-	-	-	-	-	-	-	-	-	0.363	
40X85X18	-	-	-	-	-	-	-	-	-	NX	NXR	0.467	
6308	Z	ZZ	-	LLH	LU	LLU	TMB	-	-	N	NR	0.599	
6308C	-	-	-	-	-	LLU	-	-	-	-	-	0.62	
6308RO	-	-	-	-	-	-	-	-	-	-	-	0.665	
NI334	-	-	-	-	-	-	-	-	ASTB	N	-	0.538	
6408	-	-	-	-	-	-	-	-	-	N	NR	1.21	
6009	Z	ZZ	-	-	-	LLU	-	-	-	N	NR	0.237	
SP6009	-	-	-	-	-	-	-	-	-	-	-	0.2	
6209	Z	ZZ	-	-	-	-	-	-	-	N	NR	0.4	
6209K	-	-	-	-	-	-	-	-	-	-	-	0.41	
6309	Z	ZZ	-	LLH/LLHA	-	-	TMB	TS2	-	N	NR	0.825	
6409	-	-	-	-	-	-	-	-	-	-	-	1.55	
16010	-	-	-	-	-	-	-	-	-	-	-	0.19	
6010	Z	-	-	-	LU	LLU	-	-	-	N	NR	0.262	
6210	Z	-	-	LLHA	LU	LLU	TMB	TS2	-	N	NR	0.457	
6210K	-	-	-	-	-	-	-	-	-	-	-	0.46	
6310	Z	-	LBRA	-	LU	LLU	-	-	-	AST	N	NR	1.065
6410	-	-	-	-	-	-	-	-	-	-	-	1.9	

● SINGLE ROW RADIAL BALL BEARING (Metric Series)

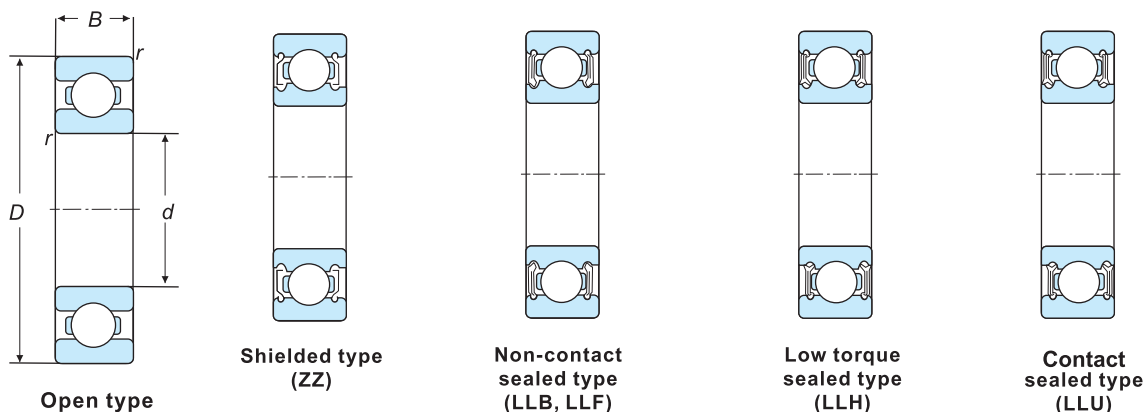

Boundary Dimensions					Load Rating				Limiting Speed (rpm)		Bearing Numbers
mm					Dynamic KN	Static	Dynamic Kgf	Static	Grese	Oil	
d	D	B_{IR}	B_{OR}	r_{smin}	C_r	C_{or}	C_r	C_{or}			Open Type
55	80	13	13	1	15.9	13.3	1622	1357	8200	9600	6911
	90	18	18	1.1	28.3	21.3	2885	2171	7700	9000	6011
	100	21	21	1.5	43.4	29.3	4424	2987	6400	7600	6211
	100	21	21	1.5	43.4	29.3	4424	2987	6400	7600	6211RO
	100	21	21	1.5	43.4	29.3	4424	2987	6400	7600	6211K
	120	29	29	2	71.5	44.4	7288	4526	5800	6800	6311
	130	31	31	1.5	87.8	52.4	8953	5343	9000	10000	N1336
60	140	33	33	2.1	93.55	56.5	9546	5765	5200	6100	6411
	85	13	13	1	16.4	14.2	1673	1449	7600	8900	6912
	95	18	18	1.1	31.66	24.22	3228	2469	7000	8300	6012
	95	11	11	0.6	20	17.5	2039	1784	6000	7000	16012
	110	22	22	1.5	47.7	32.9	4864	3355	6000	7000	6212
	110	22	22	1.5	47.7	32.9	4864	3355	6000	7000	6212RO
	110	22	22	1.5	47.7	32.9	4864	3355	6000	7000	6212K
65	130	31	31	2.1	81.8	52	8338	5301	5400	6300	6312
	150	35	35	2.1	109.2	70.3	11143	7173	4800	5700	6412
	90	13	13	1	20	17.5	2039	1784	5000	6000	6913
	100	18	18	1.5	30.5	25.2	3109	2569	6500	7700	6013
	100	11	11	0.6	20.4	18.6	2080	1897	5000	6000	16013
70	120	23	23	1.5	57.2	40.1	5831	4088	5500	6500	6213
	125	23	23	1.5	57.2	40.1	5831	4088	5500	6500	6213/125
	140	33	33	2.1	92.1	59.8	9388	6069	4900	5800	6313
	100	16	16	1	23.7	21.1	2418	2153	6500	7700	6914
75	110	20	20	1.1	38	30.8	3875	3141	6100	7100	6014
	125	24	24	1.5	62.2	44.1	6340	4495	5100	6000	6214
	150	35	35	2.1	104.13	68.04	10618	6938	4600	5400	6314
	115	20	20	1.1	40.18	33.18	4097	3383	5700	6700	6015
80	130	25	25	1.5	62.1	44.9	6330	4577	4800	5600	6215
	130	25	25	1.5	66.1	49.5	6745	5051	4800	5600	6215K
	160	37	37	2.1	113.21	76.97	11544	7848	4300	5000	6315
85	125	22	22	1.1	47.54	39.79	4847	4057	5300	6200	6016
	140	26	26	2	71.55	54.3	7296	5537	4500	5300	6216
	170	39	39	2.1	122.7	86.5	12511	8820	4000	4700	6316
85	130	22	22	2	47.3	40.15	4823	4094	4200	5000	6017
	150	28	28	2	83.2	64	8490	6531	4200	5000	6217
	150	28	28	2	83.2	64	8490	6531	4200	5000	6217K
	180	41	41	3	132.42	96.59	13503	9849	3800	4500	6317

● SINGLE ROW RADIAL BALL BEARING (Metric Series)

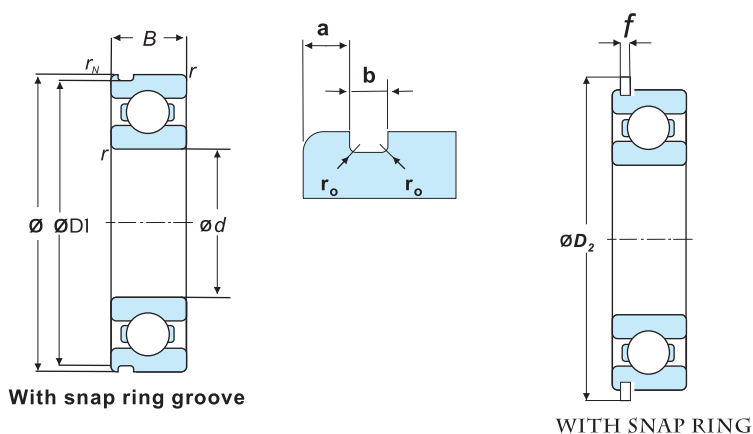

Equivalent bearing load
dynamic

$$P_r = XF_r + YF_a$$

F_a	e	$\frac{F_a}{F_r} < e$		$\frac{F_a}{F_r} > e$	
		X	Y	X	Y
C_{or}					
0.010	0.18				2.46
0.020	0.20				2.14
0.040	0.24				1.83
0.070	0.27				1.61
0.10	0.29	1	0	0.56	1.48
0.15	0.32				1.35
0.20	0.35				1.25
0.30	0.38				1.13
0.40	0.41				1.05
0.50	0.44				1.00

Static

$$P_{or} = 0.6Fr + 0.5Fa$$

when $P_{or} < Fr$ use $P_{or} = Fr$

Bearing Numbers												Mass Kg
Open Type	Shield Type	Non Contact	Low torque type	Contact type		TMB	TS2	TS3	ASTB	Snap Ring Groove	Snap Ring	(Approx.)
6911	-	-	-	-	-	-	-	-	-	-	-	0.19
6011	-	-	-	-	LLU	-	-	-	-	-	-	0.39
6211	Z	ZZ	-	-	LU	TMB	-	-	-	N	NR	0.597
6211RO	-	-	-	-	-	-	-	-	-	-	-	0.607
6211K	-	ZZ	-	-	-	-	-	-	-	-	-	0.607
6311	Z	ZZ	-	-	-	-	-	-	-	-	-	1.372
N1336	-	-	LLBA	-	-	-	-	-	AST	-	-	1.79
6411	-	-	-	-	-	-	-	-	-	-	-	2.3
6912	-	-	-	-	-	RSS	-	-	-	-	-	0.19
6012	-	-	-	-	-	-	-	-	-	-	-	0.414
16012	-	-	-	-	-	-	-	-	-	-	-	0.285
6212	Z	-	-	-	LU	LLU	-	TS2	-	N	NR	0.769
6212RO	-	-	-	-	-	-	-	-	-	-	-	0.769
6212K	-	ZZ	-	-	-	-	-	-	-	-	-	0.769
6312	Z	ZZ	-	-	-	-	-	-	-	-	-	1.689
6412	-	-	-	-	-	-	-	-	-	-	-	2.8
6913	-	-	-	-	-	-	-	-	-	-	-	0.216
6013	Z	-	-	LLH	-	LLU	-	-	-	-	-	0.425
16013	-	-	-	-	-	-	-	-	-	-	-	0.297
6213	Z	-	-	-	-	-	-	-	-	N	NR	0.98
6213/125	-	ZZ	-	-	-	RSS/LLU	TMB	-	-	-	-	1.17
6313	Z	ZZ	-	-	LU	LLU	-	-	-	-	NR	2.091
6914	-	-	-	-	-	-	-	-	-	-	-	0.334
6014	-	-	-	-	-	-	-	-	-	N	-	0.587
6214	-	-	-	-	-	-	-	-	-	-	-	1.056
6314	-	ZZ	-	-	-	-	-	-	-	-	-	2.61
6015	-	ZZ	-	-	-	RSS	-	-	-	-	-	0.649
6215	-	-	-	-	-	-	-	-	-	-	-	1.139
6215K	-	-	-	-	-	-	-	-	-	-	-	1.2
6315	-	-	-	-	-	RSS	-	-	-	-	-	3.13
6016	-	ZZ	-	-	-	-	-	-	-	-	-	0.85
6216	-	-	-	-	-	-	-	-	-	-	-	1.4
6316	-	ZZ	-	-	-	RSS	-	-	-	-	-	3.59
6017	-	-	-	-	-	-	-	-	-	-	-	0.92
6217	-	-	-	-	-	-	-	-	-	-	-	1.8
6217K	-	-	-	-	-	-	-	-	-	-	-	1.8
6317	-	ZZ	-	-	-	-	-	-	-	-	-	4.23

● SINGLE ROW RADIAL BALL BEARING (Metric Series)

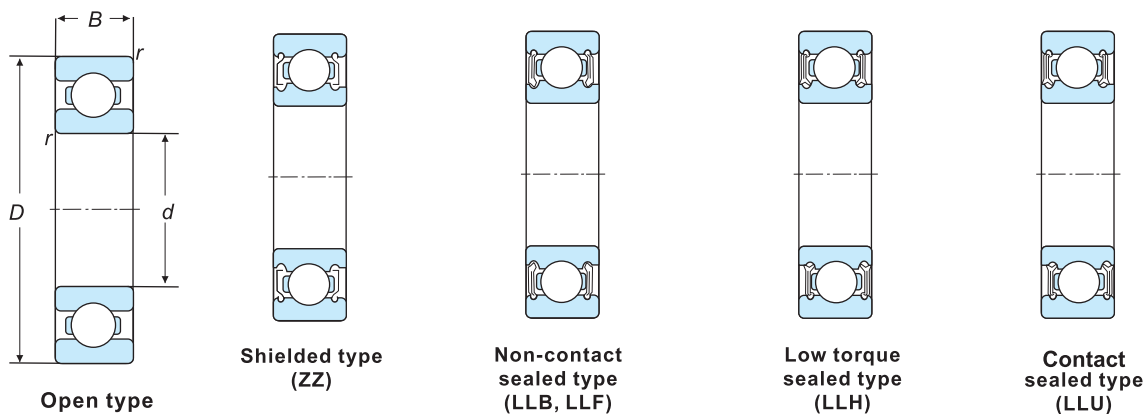

Boundary Dimensions					Load Rating				Limiting Speed (rpm)		Bearing Numbers
mm					Dynamic KN	Static	Dynamic Kgf	Static	Grese	Oil	
d	D	B _{IR}	B _{OR}	r _{smin}	C _r	C _{or}	C _r	C _{or}			Open Type
90	140	24	24	1.5	58	49.8	5918	5082	4700	5600	6018
	160	30	30	2	95.98	71.46	9687	7286	4000	4700	6218
	160	30	30	2	95.98	71.46	9794	7292	4000	4700	6218
95	190	43	43	3	142.33	107.23	14513	10934	3600	4200	6318
	145	24	24	1.5	60	53.8	6122	5490	4500	5300	6019
	200	45	45	3	156.36	121.98	15944	12438	3300	3900	6319
100	150	24	24	1.5	64.46	56.13	6573	5723	4200	5000	6020
	180	34	34	2.1	122.14	92.72	12454	9454	3500	4200	6220
	215	47	47	3	172.65	140.39	17605	14315	3200	3700	6320
105	160	26	26	2	71.9	63.36	7331	6460	4000	4700	6021
	170	28	28	2	81.8	72.8	8341	7423	3800	4500	6022
110	200	38	38	2.1	110.82	100.43	11300	10241	3200	3800	6222
	240	50	50	3	204.9	178.3	20893	18181	2900	3400	6322
120	215	40	40	2.1	155	131	15816	13367	2900	3400	6224
	260	55	55	3	207	185	21100	18800	2600	3100	6324
130	230	40	40	3	167	146	17000	14900	2700	3100	6226
140	250	42	42	3	179.1	167	18276	17031	2500	2900	6228

● SINGLE ROW RADIAL BALL BEARING (Metric Series)

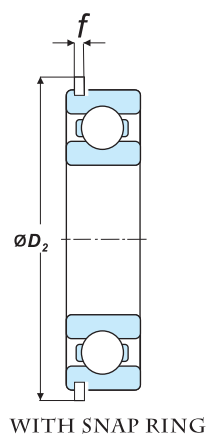
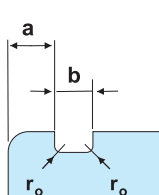
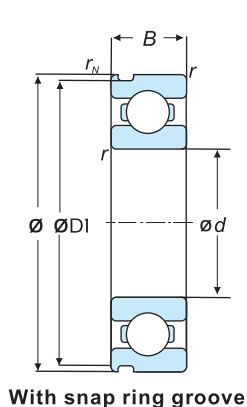

Equivalent bearing load
dynamic

$$P_r = XF_r + YF_a$$

F_a	e	$\frac{F_a}{F_r} < e$		$\frac{F_a}{F_r} > e$	
		X	Y	X	Y
C_{or}					
0.010	0.18				2.46
0.020	0.20				2.14
0.040	0.24				1.83
0.070	0.27				1.61
0.10	0.29	1	0	0.56	1.48
0.15	0.32				1.35
0.20	0.35				1.25
0.30	0.38				1.13
0.40	0.41				1.05
0.50	0.44				1.00

Static

$$P_{or} = 0.6Fr + 0.5Fa$$

when $P_{or} < Fr$ use $P_{or} = Fr$

Bearing Numbers												Mass Kg
Open Type	Shield Type	Non Contact	Low torque type	Contact type		TMB	TS2	TS3	ASTB	Snap Ring Groove	Snap Ring	(Approx.)
6018	-	-	-	-	-	-	-	-	-	-	-	1.02
6218	-	-	-	-	-	-	-	-	-	-	-	2.15
6218	-	-	-	-	-	-	-	-	-	-	-	0
6318	-	ZZ	-	-	-	-	-	-	-	-	-	4.91
6019	-	-	-	-	-	-	-	-	-	-	-	1.08
6319	-	-	-	-	-	-	-	-	-	-	-	5.67
6020	-	ZZ	-	-	-	-	-	-	-	-	-	1.15
6220	-	-	-	-	-	-	-	-	-	-	-	3.14
6320	-	ZZ	-	-	-	-	-	-	-	-	-	7
6021	-	-	-	-	-	-	-	-	-	-	-	1.59
6022	-	-	-	-	-	-	-	-	-	-	-	1.9
6222	-	-	-	-	-	-	-	-	-	-	-	4.36
6322	-	-	-	-	-	-	-	-	-	-	-	8
6224	-	-	-	-	-	-	-	-	-	-	-	5.3
6324	-	-	-	-	-	-	-	-	-	-	-	12.4
6226	-	-	-	-	-	-	-	-	-	-	-	5.82
6228	-	-	-	-	-	-	-	-	-	-	-	7.68

● SINGLE ROW RADIAL BALL BEARING (Metric Series)

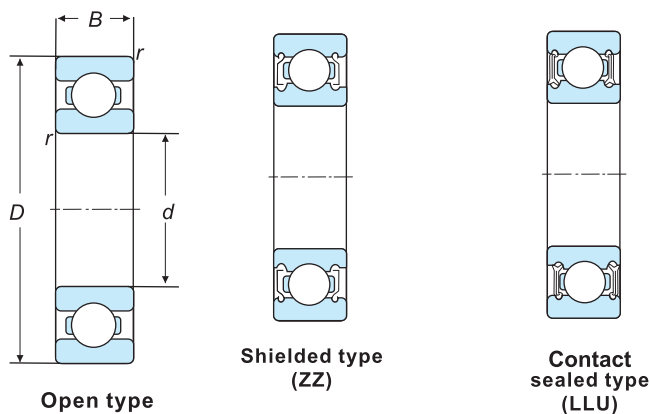

Boundary Dimensions					Load Rating				Limiting Speed (rpm)		Bearing Numbers			Mass Kg		
mm					Dynamic	Static	Dynamic	Static	Grese	Oil	Open Type	Shielded Type	Contact Type	(Approx.)		
d	D	B _{IR}	B _{OR}	r _{smin}	KN		Kgf									
					C _r	C _{or}	C _r	C _{or}								
4	13	5	5	0.3	1.3	0.485	133	49	42000	49000	624	-	-	-	LLU	0.0032
	13	5	5	0.3	1.3	0.485	133	49	42000	49000	624	-	ZZ	-	-	0.0032
	11	4	4	0.3	0.96	0.345	98	35	45000	52000	694	-	-	-	LLU	0
5	16	5	5	0.4	1.73	0.67	177	68	37000	44000	625	-	ZZ	-	LLU	0.0047
	16	5	5	0.4	1.73	0.67	177	68	37000	44000	625	-	ZZ	-	-	0.0047
6	21.01	7	7	0.3	48.3	20.3	4833	2030	21200	36200	518472B	-	-	-	-	0.016
	19	6	6	0.4	2.332	0.891	238	91	34000	40000	626	-	-	-	RSS	0.00805
	19	6	6	0.4	2.332	0.891	238	91	34000	40000	626	-	ZZ	-	-	0.00805
7	19	6	6	0.4	2.237	0.91	228	93	34000	40000	607	-	-	-	RSS	0.0075
	19	6	6	0.4	2.237	0.91	228	93	34000	40000	607	-	ZZ	-	-	0.0075
	22	7	7	0.4	3.283	1.381	335	141	32000	37000	627	-	-	-	RSS	0.0121
8	22	7	7	0.4	3.283	1.381	335	141	32000	37000	627	-	ZZ	-	-	0.0121
	22	7	7	0.4	3.3	1.37	337	140	32000	37000	608	-	-	-	RSS	0.0113
	22	7	7	0.3	3.3	1.37	337	140	32000	37000	608	-	ZZ	-	-	0.0113
	24	8	8	0.4	3.332	1.421	340	145	31000	36000	628	-	-	-	RSS	0.017
	24	8	8	0.3	3.34	1.415	341	144	31000	36000	628	-	ZZ	-	-	0.017
9	24	7	7	0.3	3.680	1.650	342	146	31000	36000	609	-	ZZ	-	-	0.0147
	26	8	8	0.4	4.566	1.979	466	202	30000	35000	629	-	-	-	RSS	0.019
	26	8	8	0.3	4.55	1.97	464	201	30000	35000	629	-	ZZ	-	-	0.019

● SINGLE ROW RADIAL BALL BEARING (SPECIAL BEARINGS) (Metric Series)

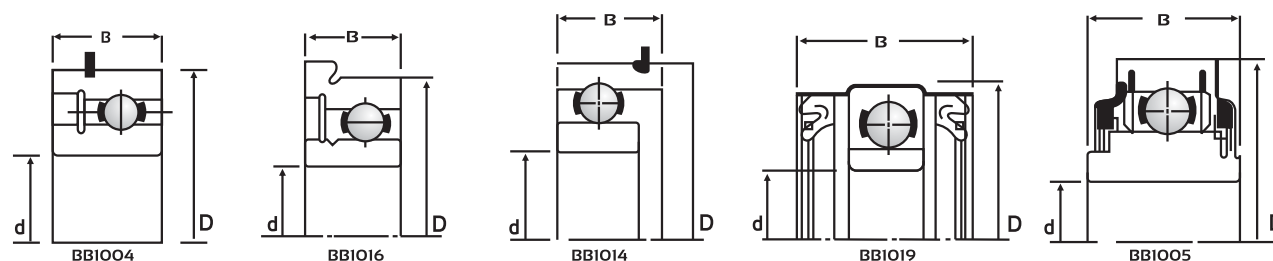

Boundary Dimensions (mm)				Basic Load Ratings (N)		Limiting Speed (rpm)		Bearing Number	Abutment and Fillet Dimensions		
d	D	B	r min.	Dynamic Cr	Static Cor	Grease	Oil		D _s max.	d _h min.	R max.
25	52	18	1.5	11500	6200	13000	15000	BB1004	30	47	1
25	52	18	1	11500	6200	13000	15000	BB1016	30	46	1
25	65	21.5	2	21300	9800	12000	14000	BB1014	32	56	1
40	82	50	-	29100	17200	8700	10000	BB1019	51	73.5	1
45	85	27	1.6	32500	19800	7800	9200	BB1005	51	70	1

BALL BEARING

Boundary Dimensions (mm)				Bearing Number	Basic Load Ratings (N)		Mass Kg. (approx.)
d	D	B	r		Dynamic Cr	Static Cor	
63.5	127	23.813	1.5	RLS20	60830	45030	1.22
100	150	16	1	16020M	45000	45000	1
101.6	184.15	31.75	3.2	RLS32	108000	88000	3.8
105	225	49	3	6321C3	240000	154000	8.05
114.3	203.2	33.337	3.2	RLS36	115000	98000	4.6
120	180	19	1	16024M	63000	63500	2
120	215	40	2.1	6224M	155000	131000	6.8
120	260	55	3	6324	228000	207000	12.4
127	228.6	34.925	3.2	RLS40	136000	118000	6.5
130	230	40	3	6226C3	165100	147800	6.13
130	280	58	4	6326	229000	214000	15.2
140	250	42	3	6228C3	179100	166900	7.68
150	320	65	4	6330 C3	278000	284000	21.4
150	225	35	2.1	6030M	132000	125000	5.5
150	230	35	2.5	306891M	120000	125000	5.5
150	270	45	3	6230	182000	205000	9.67
150	230	35	2.5	NI239	120000	125000	5.5
160	240	38	2.1	6032MB	143000	144000	6
160	240	25	1.5	16032M	95000	105000	4
170	310	52	4	6234C3	228000	239000	15.4
170	260	42	2.1	6034	161000	160000	7.8
180	280	46	2.1	6036M	189000	199000	10.5
200	250	24	1.5	61840	76000	100000	2.75
200	360	58	4	6240M	250000	300000	27
220	400	65	4	6244	275000	340000	30.4
240	360	56	3	6048MB	250000	310000	21

● SINGLE ROW RADIAL BALL BEARING
(SPECIAL BEARINGS)

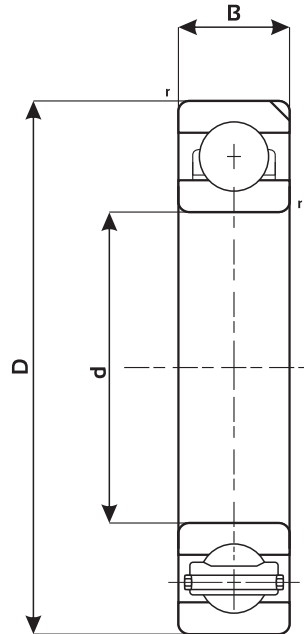

Boundry Dimensions				Bearing Number	Basic Load Ratings (N)		Mass Kg. (approx.)
(mm)					Dynamic Cr	Static Cor	
d	D	B	r				
240	440	72	4	6248M	350000	465000	51
280	380	46	2.1	61956	236000	310000	15
320	400	38	2.1	61864M	168000	240000	12
380	420	74	4	6064	370000	550000	49
630	920	128	10	60/630	816000	176000	280.00
670	980	136	7.5	60/670C3	765000	1730000	351

● SINGLE ROW RADIAL BALL BEARING (Inch Series)

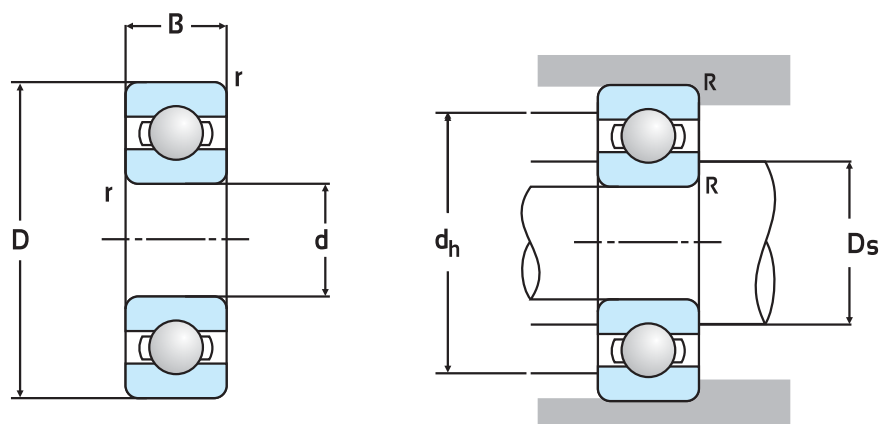

Boundary Dimensions				Basic Load Rating (N)		Limiting Speed (rpm)		Bearing Number	Abutment and Fillet Dimensions			Mass Kg, (Approx.)
d mm (inch)	D mm (inch)	B mm (inch)	r mm (inch)	Dynamic Cr	Static Cor	Grease	Oil		Ds mm (inch)	dh mm (inch)	R mm (inch)	
9.525 (0.3750)	22.225 (0.8750)	5.556 (0.2188)	0.4 (0.02)	2490	1110	32000	44000	S3	12.7 (0.5)	18.3 (0.72)	0.3 (0.01)	0.010
12.700 (0.5000)	28.562 (1.1250)	6.350 (0.2500)	0.4 (0.02)	4030	2010	23500	27000	S5	17.5 (0.69)	23.8 (0.94)	0.3 (0.01)	0.019
	33.325 (1.3125)	9.525 (0.3750)	0.8 (0.03)	6100	2750	20000	24000	LS5	17.5 (0.69)	29.5 (1.16)	0.5 (0.02)	0.037
15.875 (0.6250)	34.925 (1.3750)	7.145 (0.2813)	0.8 (0.03)	5550	2860	19000	23000	S7	20.6 (0.81)	28.6 (1.13)	0.5 (0.02)	0.033
	39.675 (1.5625)	11.113 (0.4375)	0.8 (0.03)	9600	4550	19000	23000	LS7	21.1 (0.83)	34.8 (1.37)	0.5 (0.02)	0.059
	46.025 (1.8125)	15.875 (0.6250)	1.6 (0.06)	11600	5650	16000	18000	MS7	23.1 (0.91)	39.6 (1.56)	1.1 (0.04)	0.120
19.050 (0.7500)	41.262 (1.6250)	7.938 (0.3125)	0.8 (0.03)	7380	4000	16000	18000	S8	26.2 (1.03)	35.7 (1.41)	0.5 (0.02)	0.047
	47.612 (1.875)	14.289 (0.5625)	1.6 (0.06)	13700	6650	15000	18000	LS8	25.9 (1.02)	41.1 (1.62)	1.1 (0.04)	0.110
	50.782 (2.0000)	17.463 (0.6875)	1.6 (0.06)	15900	7850	14500	17000	MS8	26.9 (1.06)	43.7 (1.72)	1.1 (0.04)	0.122
22.225 (0.8750)	47.612 (1.8750)	9.525 (0.3750)	0.8 (0.03)	9400	5220	15000	18000	S9	30.2 (1.19)	40.5 (1.59)	0.5 (0.02)	0.078
	50.782 (2.0000)	14.288 (0.5625)	1.6 (0.06)	12900	6800	14000	17000	LS9	29.7 (1.17)	44.5 (1.75)	1.1 (0.04)	0.125
	57.132 (2.2500)	17.463 (0.6875)	1.6 (0.06)	15330	8270	13000	15000	MS9	30.2 (1.19)	50.0 (1.97)	1.1 (0.04)	0.213
25.400 (1.0000)	50.800 (2.0000)	9.525 (0.3750)	0.8 (0.03)	10050	5900	14000	17000	S10	32.5 (1.28)	42.9 (1.69)	0.5 (0.02)	0.083
	57.132 (2.2500)	15.875 (0.6250)	1.6 (0.06)	17700	9700	12500	15000	LS10	33.3 (1.31)	50 (1.97)	1.1 (0.04)	0.166
	63.482 (2.5000)	19.050 (0.7500)	2.4 (0.09)	21250	11050	12000	14000	MS10	34.8 (1.37)	54.5 (2.14)	1.6 (0.06)	0.267
28.575 (1.1250)	63.482 (2.5000)	15.875 (0.6250)	1.6 (0.06)	19450	11300	12000	14000	LS11	38.1 (1.50)	56.4 (2.22)	1.1 (0.04)	0.225
	71.420 (2.8125)	20.638 (0.8125)	2.4 (0.09)	27000	14350	10500	12500	MS11	38.1 (1.50)	61.5 (2.42)	1.6 (0.06)	0.363

● SINGLE ROW RADIAL BALL BEARING (Inch Series)

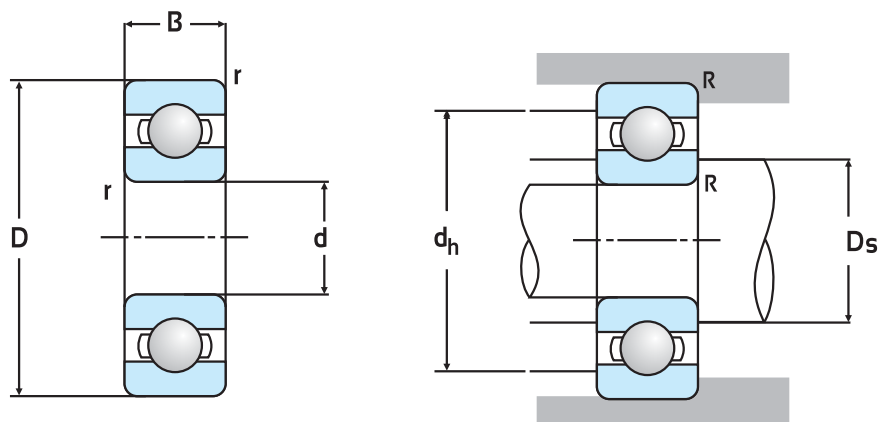

Boundary Dimensions				Basic Load Rating (N)		Limiting Speed (rpm)		Bearing Number	Abutment and Fillet Dimensions			Mass Kg, (Approx.)
d mm (inch)	D mm (inch)	B mm (inch)	r mm (inch)	Dynamic Cr	Static Cor	Grease	Oil		Ds mm (inch)	dh mm (inch)	R mm (inch)	
31.75000 (1.2500)	69.832 (2.7500)	17.463 (0.6875)	1.6 (0.06)	17800	11200	10000	13000	LS12	41.4 (1.63)	62.7 (2.47)	1.1 (0.04)	0.307
	79.375 (3.1250)	22.225 (0.8750)	2.4 (0.09)	33300	18000	9200	10500	MS12	43.7 (1.72)	69.1 (2.72)	1.6 (0.06)	0.480
34.925 (1.37500)	76.175 (3.0000)	17.463 (0.6875)	1.6 (0.06)	20800	13300	10000	12000	LS12½	46.0 (1.81)	68.3 (2.69)	1.1 (0.04)	0.367
	88.875 (3.2500)	22.225 (0.8750)	2.4 (0.09)	37200	22050	8600	10000	MS12½	47.8 (1.88)	76.2 (3.00)	1.6 (0.06)	0.639
38.100 (1.5000)	82.525 (3.2500)	19.050 (0.7500)	2.4 (0.09)	25700	16000	9000	10000	LS13	49.3 (1.94)	73.4 (2.89)	1.6 (0.06)	0.446
	95.225 (3.7500)	23.813 (0.9375)	2.4 (0.09)	47700	26700	8000	9500	MS13	50.8 (2.00)	82.6 (3.25)	1.6 (0.06)	0.761
41.275 (1.6250)	88.875 (3.5000)	19.050 (0.7500)	2.4 (0.09)	27500	18100	8500	10000	LS13 ½	54.1 (2.13)	77.77 (3.06)	1.6 (0.06)	0.535
	101.575 (4.0000)	23.813 (0.9375)	2.4 (0.09)	48300	277500	7600	9000	MS13½	56.6 (2.23)	88.1 (3.47)	1.6 (0.06)	0.862
44.450 (1.7500)	95.250 (3.7500)	20.638 (0.8125)	2.4 (0.09)	35000	23200	8000	9500	LS14	57.2 (2.25)	87.1 (3.31)	1.6 (0.06)	0.654
	107.95 (4.2500)	26.988 (1.0625)	2.4 (0.09)	56250	32700	7000	8300	MS14	59.4 (2.34)	93.7 (3.69)	1.6 (0.06)	1.084
47.625 (1.875)	101.575 (4.0000)	20.638 (0.8125)	2.4 (0.09)	48700	31200	7800	9200	LS14 ½	63.5 (2.50)	92.2 (3.63)	1.6 (0.06)	0.710
	114.30 (4.5000)	26.988 (1.0625)	2.4 (0.09)	62100	38500	6700	8000	MS14 ½	65.0 (2.56)	100.1 (3.94)	1.6 (0.06)	1.240
50.8 (2.0000)	101.60 (4.0000)	20.638 (0.8125)	2.4 (0.09)	48700	31200	7800	9200	LS15	63.5 (2.50)	92.2 (3.63)	1.6 (0.06)	0.671
	114.30 (4.5000)	26.988 (1.0625)	2.4 (0.09)	62100	38500	6700	8000	MS15	65.0 (2.56)	100.1 (3.94)	1.6 (0.06)	1.189

● SINGLE ROW ANGULAR CONTACT BALL BEARING (Metric Series)

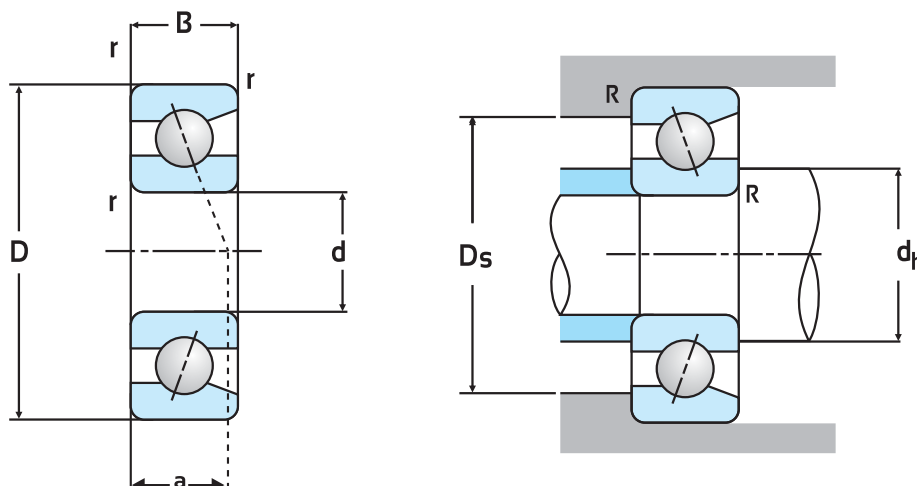

Boundary Dimensions				Basic Load Rating (N)		Limiting Speed (rpm)		Bearing Number	Abutment and Fillet Dimensions			Load Center a	Mass Kg, (Approx.)
d	D	B	r min	Dynamic Cr	Static Cor	Grease	Oil		dh max.	Ds min.	R max.		
15	35	11	0.6	7940	4290	18000	25000	7202B	19.5	30.5	0.6	16	0.05
17	40	12	0.6	1000	5500	15000	21000	7203	22	35	1.0	14.5	0.064
20	47	14	1.0	1330	7600	14000	18000	7204	26	41	1.0	17	0.100
25	52	15	1	14800	9400	12000	16000	7205B	30.5	46.5	1	24	0.13
30	62	16	1	20500	13500	11000	14000	7206B	35.5	56.5	1	27.5	0.2
	72	19	1.1	31100	19300	9600	13000	7306B	37	65	1	31.5	0.35
35	72	17	1.1	27100	18400	8600	11000	7207	42	65	1.0	24	0.281
35	80	21	1.5	38300	24400	8400	11000	7307B	43.5	71.5	1.5	34.5	0.47
40	90	23	1.5	46500	29500	6900	9200	7308	48.5	81.5	1.0	30.5	0.625
	80	18	1.1	34500	23900	8300	11000	7208B	47	73	1	34	0.38
45	120	29	2.0	80200	53650	4500	5800	7409	60	100	1.0	55.8	1.83
	85	19	1.1	33900	24800	7400	9900	7209B	52	78	1	37	0.47
	100	25	1.5	59600	39600	6600	8900	7309B	53.5	91.5	1.5	43	0.84
50	110	27	2.0	69300	47200	5600	7500	7310	60	100	1.0	36.5	1.090
	90	20	1.1	37400	28600	6700	9000	7210B	57	83	1	39.5	0.5
55	100	21	1.5	46300	36100	6100	8200	7211B	63.5	91.5	1.5	43	0.61
60	110	22	1.5	56100	44400	5300	7000	7212	68.5	101.5	1.0	36	0.765
65	120	23	1.5	63600	52600	5200	7000	7213B	73.5	111.5	1.5	50.5	0.98
75	130	25	1.5	68600	58300	4500	6000	7215B	83.5	80.5	1.5	56	1.22
80	160	37	2.1	125000	97500	4100	5400	7315B	87	148	2	68	3.13
	140	26	2.0	80500	69500	4300	5700	7216B	91	134	2	55.5	3.65
	170	39	2.1	135000	109000	3800	5100	7316B	92	158	2	72	3.72
85	150	28	2.0	90000	80500	4000	5300	7217B	96	139	2	63.5	1.82
90	190	43	3.0	156000	135000	3400	4500	7318B	104	176	2.5	80.5	5.16
95	170	32	2.1	121000	107000	3500	4700	7219B	107	158	2	71.5	2.72
100	215	47	3.0	190000	178000	3200	4200	7320B	114	201	2.5	89.5	7.32

● SINGLE ROW ANGULAR CONTACT BALL BEARING (Inch Series)

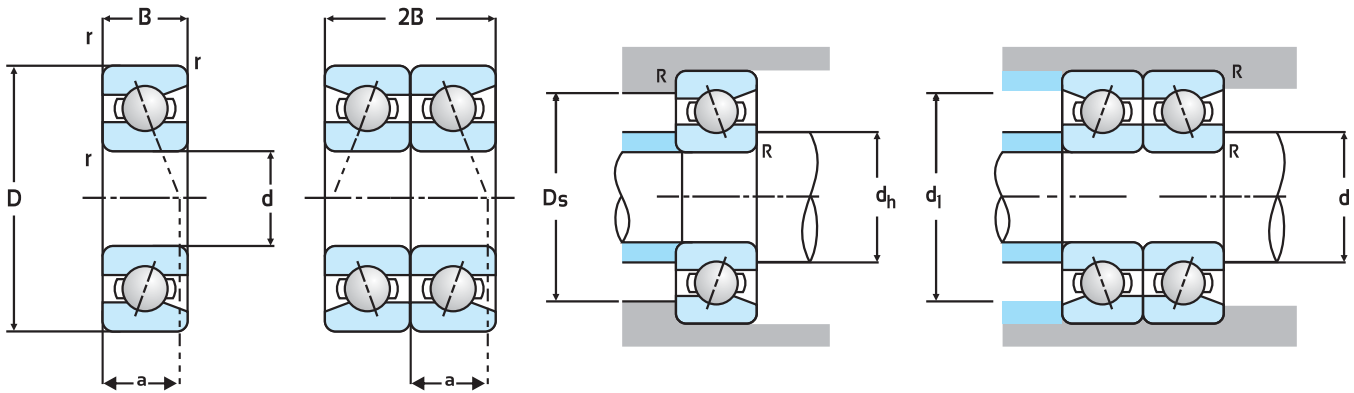

Boundary Dimensions (mm)				Basic Load Rating (N)		Limiting Speed (rpm)		Bearing Number	Abutment and Fillet Dimensions				Load Center	Mass Kg, (Approx.)
d mm (inch)	D mm (inch)	B mm (inch)	r mm (inch)	Dynamic Cr	Static Cor	Grease	Oil		d _h mm (inch)	D _s mm (inch)	d _i mm (inch)	R mm (inch)	a mm (inch)	
82.550 (3.5000)	152.362 (6.0000)	26.988 (1.0625)	2.4 (0.09)	88400	80100	2600	3500	LS19½ ACD	100.0 (3.94)	134.0 (5.28)	-	2.0 (0.08)	73.6 (2.90)	2.27
	152.362 (6.0000)	53.975 (2.125)	2.4 (0.09)	176800	155800	2600	3500		N4711C	100.0 (3.94)	140.0 (5.51)	-	2.0 (0.08)	73.6 (2.90)

● SINGLE ROW EXTERNALLY ALIGNING BALL BEARING

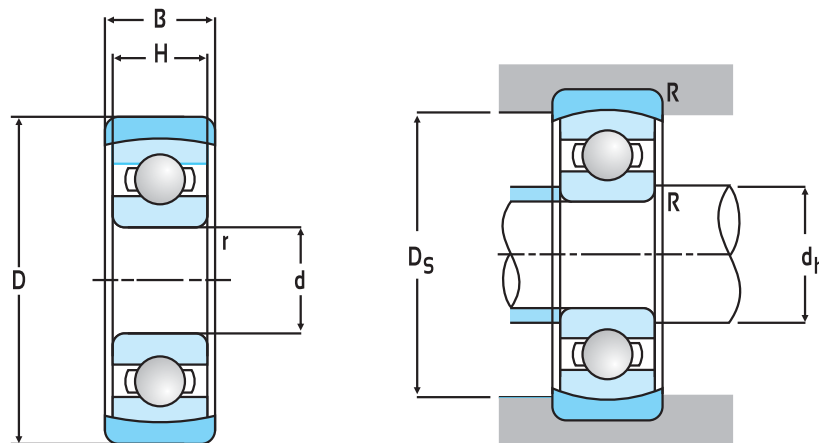

Boundary Dimensions (mm)					Basic Load Rating (N)		Limiting Speed (rpm)		Bearing Number	Abutment and Fillet Dimensions			Mass Kg, (Approx.)
d mm (inch)	D mm (inch)	B mm (inch)	H mm (inch)	r mm (inch)	Dynamic Cr	Static Cor	Grease	Oil		d _h mm (inch)	D _s mm (inch)	R mm (inch)	
44.45 (1.7500)	117.450 (4.6250)	28.575 (1.1250)	26.988 (1.0625)	2.4 (0.09)	56250	32700	6500	900	MSN14	59.4 (2.34)	110 (4.33)	1.6 (0.06)	1.7

● DOUBLE ROW SELF ALIGNING BALL BEARING (Metric Series)

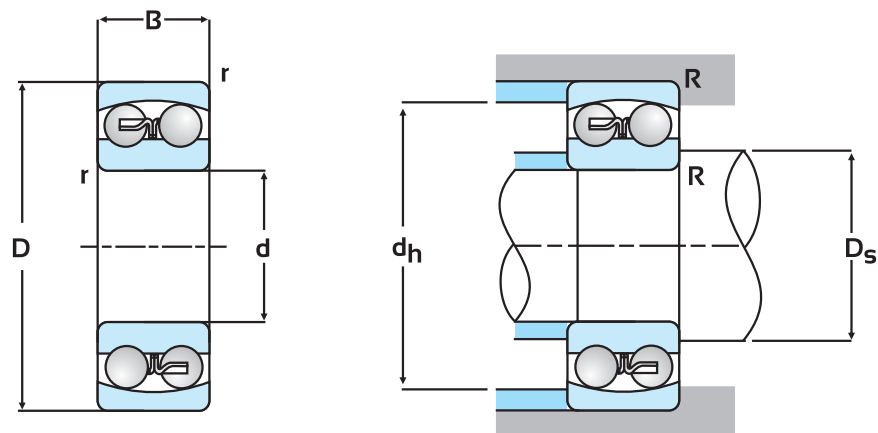

Boundary Dimensions				Basic Load Rating (N)		Limiting Speed (rpm)		Bearing Number	Abutment and Fillet Dimensions			Mass Kg, (Approx.)
d	D	B	r min.	Dynamic Cr	Static Cor	Grease	Oil		Ds max.	dh min.	R max.	
12	32	14	0.6	5550	1250	22000	26000	2201	16	28	0.6	0.052
17	40	12	0.6	8100	7300	14000	17000	1203	21	36	1	0.72
20	47	14	1.0	7650	3180	13000	15000	1204	25	42	1.0	0.114
	52	15	1.1	9600	4020	11000	13000	1304	27	46	1.0	0.158
25	62	17	1.1	18100	4900	9100	11000	1305	32	55	1.0	0.263
	52	15	1.0	12100	3300	11000	13000	1205	30	47	1.0	0.138
	52	18	1	12630	3560	12000	14000	2205	30	47	1	0.18
	62	24	1.1	24500	6480	9500	12000	2305	31.5	55.5	1	0.35
30	62	16	1.0	15600	4650	9200	11000	1206	36	56	1.0	0.231
	72	19	1.1	21200	6200	7700	9100	1306	37	65	1.0	0.395
	72	19	1.1	21500	7750	8500	11000	1306K	36.5	65.5	1	0.39
	62	20	1	15300	4550	10000	12000	2206	35	57	1	0.66
	72	27	1.1	31500	8680	8000	10000	2306	36.5	65.5	1	0.5
35	80	21	1.5	25490	7940	7500	9500	1307	43	72	1.5	0.53
	72	23	1.1	21800	6650	8500	10000	2207	41.5	65.5	1	0.4
40	80	18	1.1	19700	6700	7100	8400	1208	47	73	1.0	0.417
	90	23	1.5	29500	9500	6700	8500	1308K	48	82	1.5	0.72
	80	23	1.1	22800	7380	7500	9000	2208K	46.5	73.5	1	0.53
	90	33	1.5	45200	13200	6300	8000	2308	48	82	1.5	0.9
	90	33	1.5	45700	13600	6300	8000	2308K	48	82	1.5	0.9
45	85	19	2.0	21900	7350	6400	7500	1209	52	78	1.0	0.481
	100	25	1.5	38000	12800	6000	7500	1309K	53	92	1.5	0.957
	85	23	1.1	23300	8150	7100	8500	2209K	51.5	78.5	1	0.52
	100	36	1.5	55000	16200	5600	7100	2309	53	92	1.5	1.3
	100	36	1.5	55000	16200	5600	7100	2309K	53	92	1.5	1.3
50	100	25	1.5	38400	12900	6000	7500	1309	53	92	1.5	0.96
	110	40	2	64500	19800	5000	6300	2310	59	101	2	1.6
	110	40	2	64500	19800	5000	6300	2310K	59	101	2	1.6
55	100	21	2.0	26800	10000	5300	6200	1211	63.5	91.5	1.5	0.703
	100	25	1.5	26700	9900	6000	7011	2211K	63	92	1.5	0.75
	120	43	2	76500	19800	4800	6000	2311K	64	111	2	2.1
	120	43	2	76600	23900	4800	6000	2311	64	111	2	2.1

● DOUBLE ROW SELF ALIGNING BALL BEARING (Metric Series)

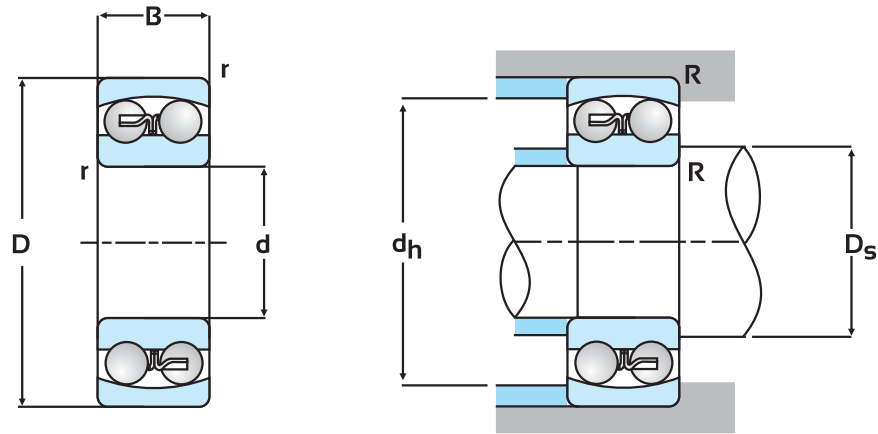

Boundary Dimensions				Basic Load Rating (N)		Limiting Speed (rpm)		Bearing Number	Abutment and Fillet Dimensions			Mass Kg, (Approx.)
d	D	B	r min.	Dynamic Cr	Static Cor	Grease	Oil		D _s max.	d _h min.	R max.	
60	110	22	1.5	30500	11500	5300	6300	1212	68	102	1.5	0.82
	110	22	1.5	30500	11500	5300	6300	1212K	68	102	1.5	0.82
65	120	23	1.5	30900	12500	4800	6000	1213K	73	112	1.5	0.92
	140	48	2	96600	32500	3800	4800	2313	76	129	2	3.2
	140	48	2	96600	32500	3800	4800	2313K	76	129	2	3.2
70	150	51	2.1	110000	37500	3600	4500	2314	81	139	2	3.9
75	130	25	1.5	38700	16000	3900	4600	1215	83.5	121.5	1.5	1.460
	130	31	1.5	44200	18000	4300	5300	2215K	83	122	1.5	1.72
80	140	26	2	39700	17100	4000	5000	1216K	89	131	2	1.7
	170	58	2.1	137000	48500	3200	4000	2316	91	159	2	6.3
85	150	28	2	44800	20500	3800	4500	1217K	94	14	2	2.095
	180	60	3	140000	53400	3000	3800	2317	98	167	2.5	7.3
100	180	34	2.1	69300	29900	3200	3800	1220K	111	169	2	3.8

● DOUBLE ROW SELF ALIGNING BALL BEARING (Inch Series)

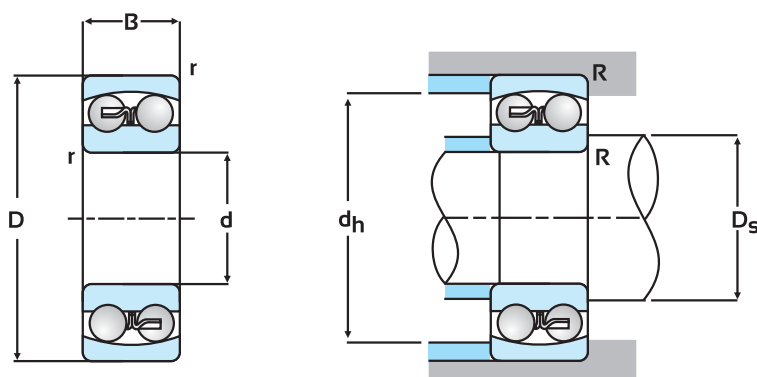

Boundary Dimensions (mm)				Basic Load Rating (N)		Limiting Speed (rpm)		Bearing Number	Abutment and Fillet Dimensions			Mass Kg, (Approx.)
d mm (inch)	D mm (inch)	B mm (inch)	r mm (inch)	Dynamic Cr	Static Cor	Grease	Oil		D _s mm (inch)	d _h mm (inch)	R mm (inch)	
31.750 (1.250)	69.850 (2.750)	17.460 (0.688)	1.6 (0.06)	19150	5750	10700	14500	ULS12V	45.0 (1.77)	61.2 (2.41)	1.6 (0.06)	0.324

● DOUBLE ROW SELF ALIGNING BALL BEARINGS WITH TAPER CLAMPING SLEEVE AND NUT

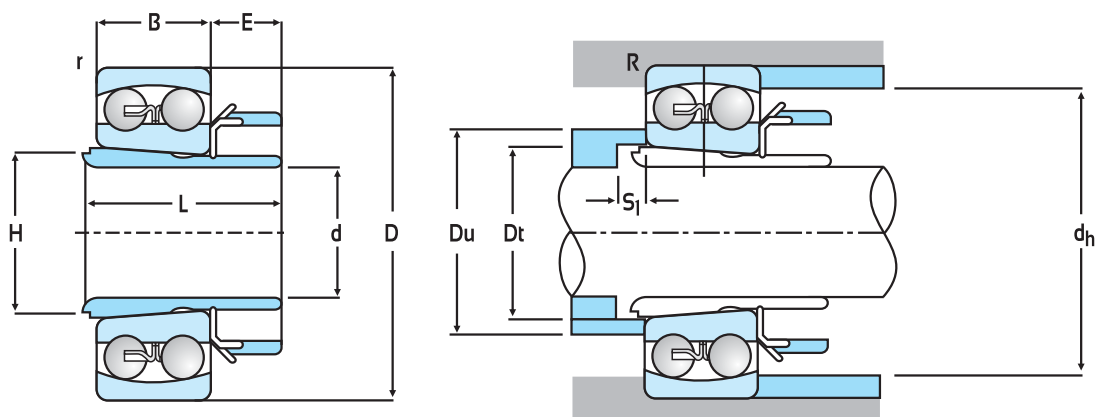

METRIC SERIES

Boundary Dimensions (mm)							Basic Load Rating (N)		Limiting Speed (rpm)		Bearing Number	Abutment and Fillet Dimensions					Mass Kg, (Approx.)
d	D	B	L	E	H	r	Dynamic Cr	Static Cor	Grease	Oil		D _t max.	D _o max.	d _h min.	S ₁ max.	R max.	
20	52	15	26	8.0	26.00	1.0	12100	3300	11000	13000	1205K	28	33	46	5	0.5	0.250
25.4	62	16	34	11.2	30.96	1.0	15600	4650	9200	11000	1206K	35	39	56	9	0.5	0.347
31.75	80	18	38	12.4	40.08	2.0	19700	6550	7100	8400	1208K	46	52	70	10	1.0	0.680
38.10	85	19	40	12.4	46.83	2.0	21900	7350	6400	7500	209K	54	57	75	11	1.0	0.753
50.80	100	21	46	13.6	57.15	2.0	26800	10000	5300	6200	1211K	63	69	88	13.5	1.0	1.08
63.5	130	25	56	15.3	76.71	2.0	38700	16000	3900	4600	1215K	81	93	118	18	1.0	2.354

● SPECIAL BEARING RACES

	d	D	B
BB1006	27	45	10.5
BB1030	27.8	46.2	8
BB1031	27.8	47.2	8

	d	D	B
BB1007	24.2	39	8.65
BB1058	25	48	5.5
BB1059	30	48	5.5

	d	D	B
BB1008	32	42.3	8

	d	D	B
BB1009	17.04	20.05	14.1
RB5005	22.03	28.0	12
RB5003	23.29	31.79	9.63
RB5004	38.10	47.63	19.18

	d	D	B
BB1060	31	48	5.5
BB1061	26	48	5.5

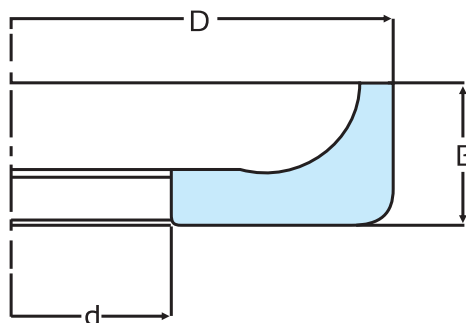
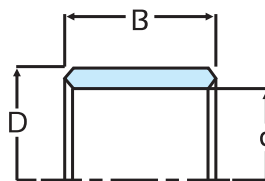
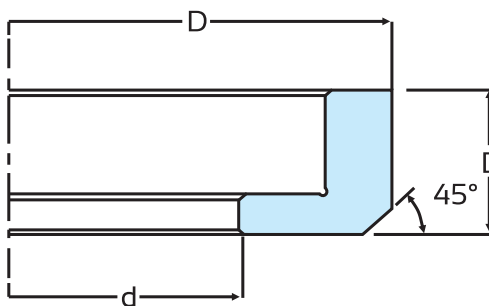
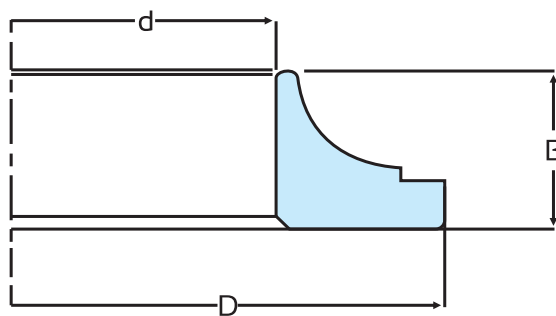
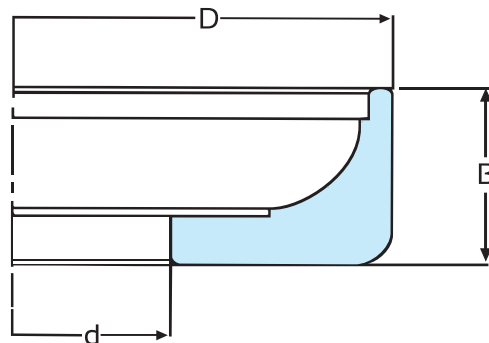

Double Row Angular Contact Sealed Bearings (Wheel Application)

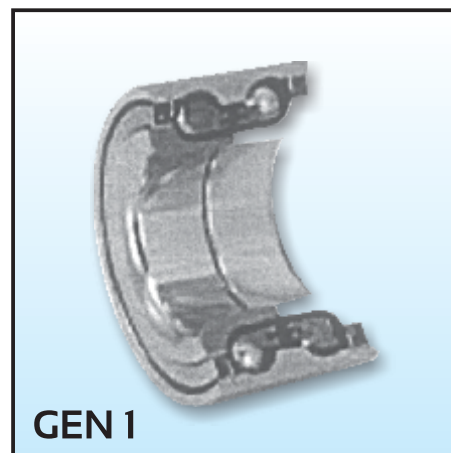
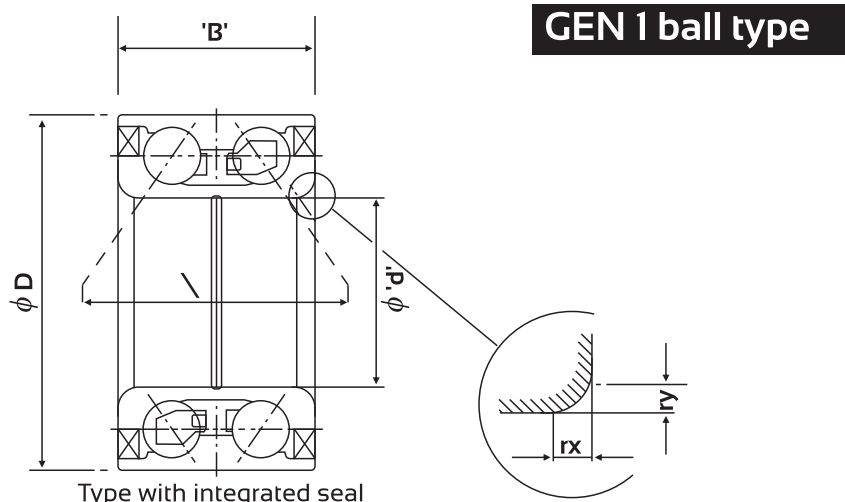

Boundry Dimensions (mm)					Distance Between Pressure Cone Apexes (mm)	Bearing Number	Basic Load Rating (rN) Double Row		Mass (Approx.)
d	D	B	rx (min.)	ry (min.)			Dynamic Cr	Static Cor	
25	52	42	3.5	2.5	50.3	AU1109-2LLX2	33.6	27	0.366
25	55	48	2.5	2.5	62.9	AU0504-11LXL/L588	34	29	0.499
35	61.8	40	3.5	3.5	54.7	AU1103M-2LLX2	35	34	0.422
37	72	37	2.5	2.5	53.1	AU0727-14LL/L588	56.2	52	0.63
37	72	37	2.5	2.5	53.1	AU0754-2LXL/L588	56.2	52	0.624
37	72	37	2.5	2.5	53.1	AU0727-15LXL/L588	56.2	52	0.628
28	58	44	3.5	2.5	53.0	AU1105-2LLX2	39.3	32	0.47
35	68	37	3.5	3.5	52.6	AU1101-2LLX2	45.9	43.1	0.535
36	68	33	3.5	3.5	52.6	AU1107-2LLX2	45.9	43.1	0.47

Lubrication

The objective of lubrication is to form a film of oil on rolling or sliding surface to prevent the metals from making direct contact with each other, Lubrication has the following effects:

1. Reduces friction and wear.
2. Extends Bearing life.
3. Prevents rusting.
4. Prevents penetration of foreign matter.

Fretting wear particularly tends to occur on the raceway of DRAC Bearing during transport of finished automobiles. Therefore the fretting resistance property of Lubricant should be taken into account while selecting lubricant for DRAC Bearings.

Characteristics	Resists fretting, enhances protection against rust
Maker	Nippon Oil Japan
Name	PYRONOC Universal N6B/N6C
Thickener	Urea
Base Oil	Mineral Oil
Working Temperature	-30 to 150 C
Colour	Cream
Remarks	Fretting Resistance Excellent Recommended grease for Passenger Cars

Seals

A special Low torque high performance (LTHP) seal on both sides of the DRAC Bearing prevent water ingress in the bearing and have low torque. It consists of 3-lips - Grease Lip, Dust Lip and Side Lip. A stainless Steel Slinger is added to the 3-lip seal sliding part, which dramatically enhances rust resistance of the sliding part of the lips. Side lip is added for improving the sealing performance.

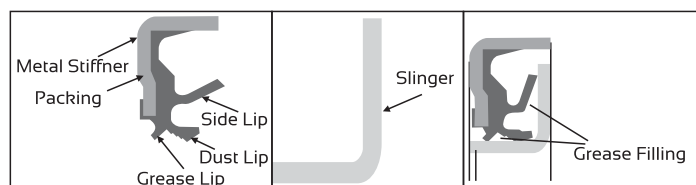

Double Row Angular Contact Sealed Bearings (Wheel Application)

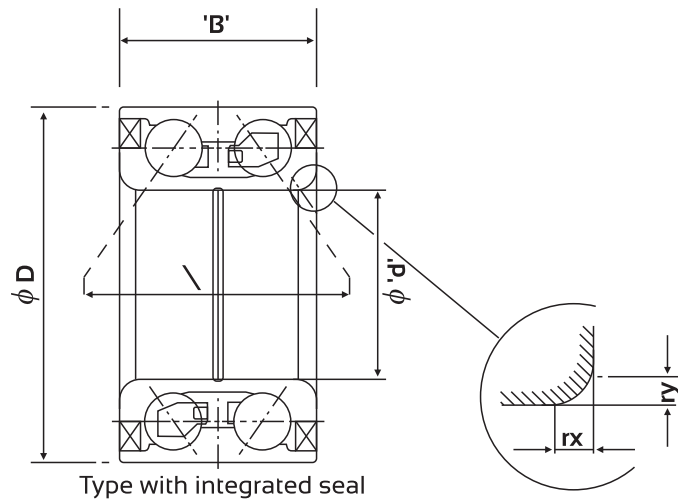

Main Dimensions (mm)					Bearing Number	Basic Load Rating (kN) Double Row		Mass (Approx.)
d	D	B	rx (min.)	ry (min.)		Dynamic Cr	Static Cor	
10	30	14	0.6	0.6	3200	7.35	4.2	0.05
12	32	15.9	0.6	0.6	3201	10.1	5.6	0.06
	32	15.9	0.6	0.6	3201ZZ	10.1	5.6	0.06
	42	19	1	1	3302	17.5	11.9	0.13
15	35	15.9	0.6	0.6	3202	11.8	7.1	0.07
	35	15.9	0.6	0.6	3202ZZ	11.8	7.1	0.07
	47	22.2	1	1	3303	21.7	17.1	0.15
17	40	17.5	0.6	0.6	3203	14.9	9.2	0.09
	40	17.5	0.6	0.6	3203ZZ	14.9	9.2	0.09
	47	20.6	1	1	3204	19.7	12.5	0.16
20	47	20.6	1	1	3204ZZ	19.7	12.5	0.16
	52	22.2	1	1	3304	22.1	13.4	0.22
25	52	20.6	1	1	3205	20.5	13.4	0.2
30	52	22	1	1	30BD5222	15.6	12.4	0.140
	62	23.8	1	1	3206	29.4	21.5	0.29
35	52	20	1.0	1.0	35BD5220	10.8	10.2	0.107
	72	27	1.1	1.1	3207	39.3	28.5	0.44
40	80	30.2	1.1	1.1	3208	44.9	33.5	0.58
	90	36.5	1.5	1.5	3308	59.2	43	0.95
45	85	30.2	1.1	1.1	3209	47.2	45.5	0.7
	100	39.7	1.5	1.5	3309	87.1	74.4	1.37
50	90	30.2	1.1	1.1	3210	53.2	43.5	0.66
	110	44.4	2	2	3310	88.5	67	1.93
55	100	33.3	1.5	1.5	3211	56.7	49.4	0.15
60	110	36.5	1.5	1.5	3212	74.4	63.2	0.15

Double Row Angular Contact Sealed Bearings (Wheel Application)

GEN 2 ball type

Boundry Dimensions											Distance Between Pressure Cone Apexes	Bearing Number	Basic Rated Load (kN) Single Row		No. of Hub Bolts	Mass (kg) (reference)
d	D	Bi	B1	Ba	Df	Dw	Db	Pb	rx (min.)	ry (min.)	l (min.)		Cr	Cor		
28	64	18	40	49.5	134	60	64	14.3	3.5	2.5	49.7	BB1072	26.2	16.5	4	1.64

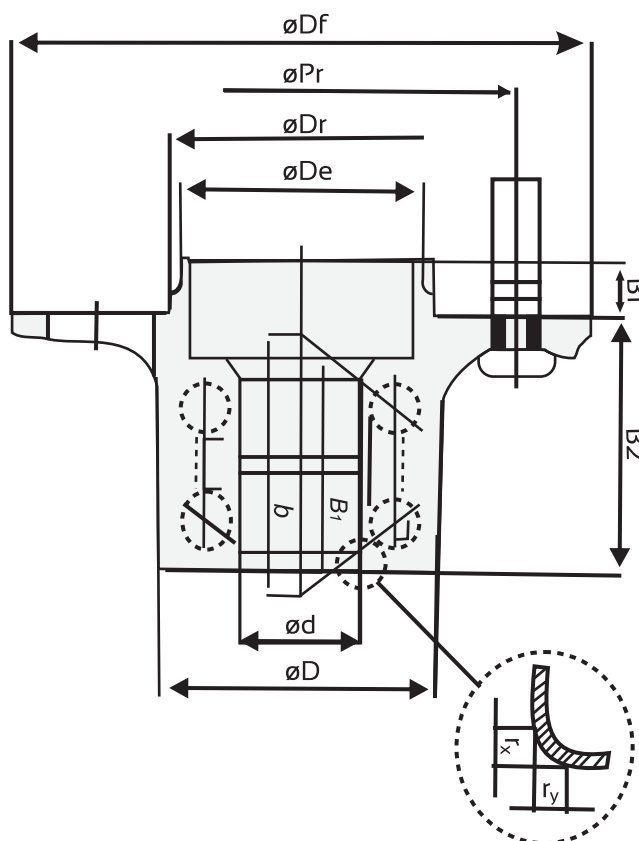

SPECIAL BEARINGS

Clutch Release Bearing

Bearing Number	Boundry Dimensions			Basic Load Rating (N)	
	d	D	B	Dynamic Cr	Static Cor
FCR44-36	28.2	55.6	32	-	-
FCR44-36-1	28.2	50	32	-	-
1888451	45	86.6	28	32700	20500
1888180	50	91.6	29	35000	23200
306445C	50	81.6	25	21800	16600
SP306445C	50	81.6	21	21800	16600
CR1002	65	101.6	27	30500	25200
NI264	65	100	23.7	26.8	21.8

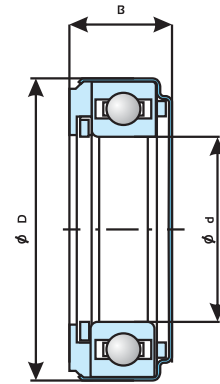

Belt Tensioners

Bearing Number	Boundry Dimensions			Basic Load Rating (N)	
	d	D	B	Dynamic Cr	Static Cor
JPU51-15	-	51	30.4	9400	5050
BB1079	-	51	32	10100	5850

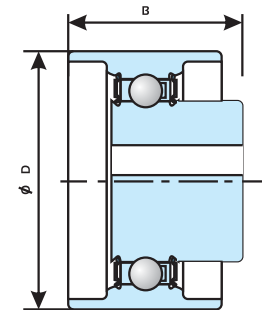

SINGLE ROW RADIAL BALL BEARING (SPECIAL BEARING)

METRIC SERIES

Boundry Dimensions (mm)					Basic Load Rating (N)		Limiting Speed (rpm)		Bearing Number	Abutment and Fillet Dimensions		
d	D	B	B ₁	r min.	Dynamic Cr	Static Cor	Grease	Oil		D _s max.	d _h min.	R max.
35	72	18.5	15	-	25700	15400	9800	11000	BB1103	45	65.5	1.5
22	22	18.5	15	-	20700	10400	14000	17000	63/22SPL	31	50	1.5

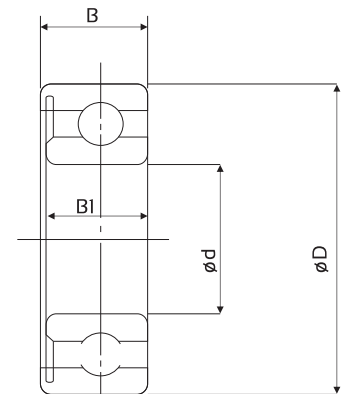

METRIC SERIES

● Pillow blocks cast housing
Set screw type

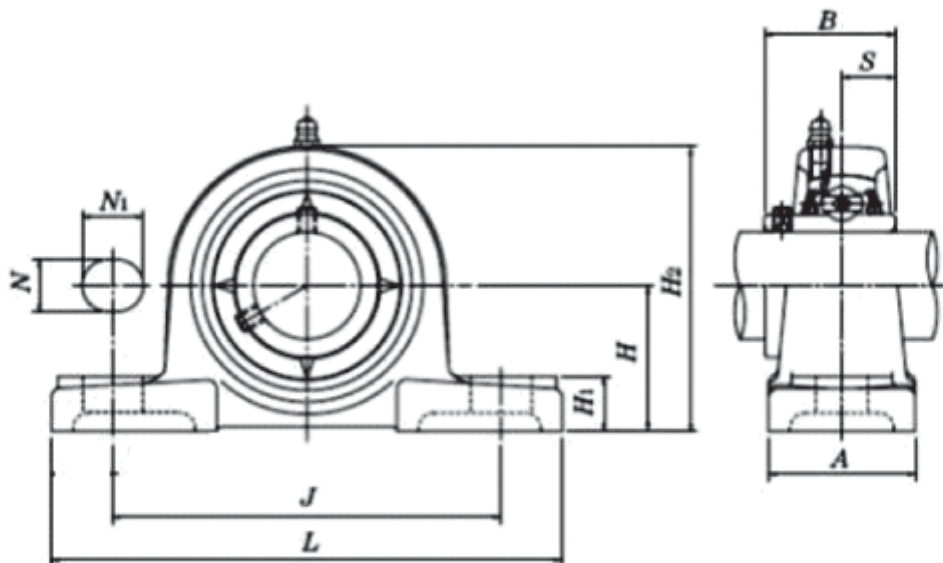

Shaft Dia	Unit No.	H	L	J	A	N	N ₁	H ₁	H ₂	B	S	Bearing No.	Mass (Kg.)
19.05	UCP204-12	33.3	127	95	38	13	19	15	65	31	12.7	UC204-12	0.7
20	UCP204	33.3	127	95	38	13	19	15	65	31	12.7	UC204	0.7
25	UCP205DI	36.5	140	105	38	13	19	15	71	34.1	14.3	UC 205 DI	0.8
25	UCP205	36.5	140	105	38	13	19	15	71	34.1	14.3	UC205	0.8
25.4	UCP205-16	36.5	140	105	38	13	19	15	71	34.1	14.3	UC205-16	0.8
28.575	UCP206-18	42.9	165	121	48	17	21	17	83	38.1	15.9	UC206-18	1.17
30	UCP206	42.9	165	121	44	14	19	16	83	38.1	15.9	UC206	1.28
31.75	UCP207-20	47.6	167	126	48	17	21	18	94	42.9	17.5	UC207-20	1.5
	UCP206-20	42.9	165	121	48	17	21	18	83	38.1	15.9	UC206-20	1.17
35	UCP207	47.6	167	126	48	17	21	18	94	42.9	17.5	UC207	1.5
38.1	UCP208-24	49.2	183	136	54	17	21	19	98	49.2	19	UC208-24	1.98
40	UCP208	49.2	183	136	54	17	21	19	98	49.2	19	UC208	1.91
44.45	UCP209-28	54	189	146	54	17	21	21	106	49.2	19	UC209-28	2.09
45	UCP209	54	189	146	54	17	21	21	106	49.2	19	UC209	2.08
50	UCP210	57.2	207	160	60	20	25	22	113	51.6	19	UC210	2.58
50.8	UCP211-32	63.5	219	170	58	20	25	24	126	55.6	22.2	UC211-32	3.62
55	UCP211	63.5	219	170	58	20	25	24	126	55.6	22.2	UC211	3.25
57.15	UCP212-36	69.8	238	183	70	20	23	26	138	65.1	25.4	UC212-36	4.5
60	UCP212	69.8	238	183	70	20	23	26	138	65.1	25.4	UC212	4.32
63.5	UCP213-40	76.2	263	202	70	25	29	28	150	65.1	25.4	UC213-40	5.38
65	UCP213	76.2	263	202	70	25	29	28	150	65.1	25.4	UC213	5.38
75	UCP215	82.6	275	216	75	25	30	28	161	77.8	33.3	UC215	7.2
76.2	UCP215-48	82.6	275	216	75	25	30	28	161	77.8	33.3	UC215-48	7.2

● Ball Bearing
Set screw type

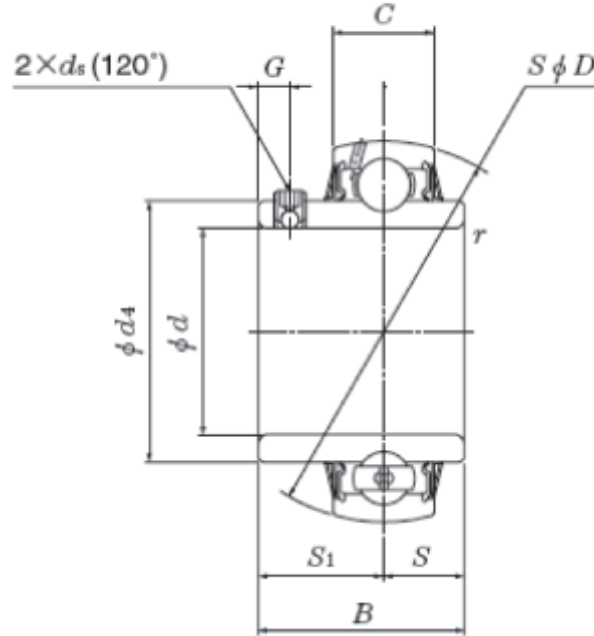

Shaft Dia	Unit NO.	d	D	B	C	r _s Min.	S	S ₁	G	d _s	Basic Load Rating		Mass (Kg.)
											Dynamic C _r	Static C _{or}	
19.05	UC204-12	19.05	47	31	16	1	12.7	18.3	5	2-1/4-28	12.8	6.63	0.16
20	UC204	20	47	31	17	1	12.7	18.3	5	2-M6 X 1	12.8	6.65	0.16
25	UC205	25	52	34.1	17	1	14.3	19.78	5.55	2-M6 X 1	14.1	7.88	0.19
25.4	UC205-16	25.4	52	34.1	17	1	14.3	19.78	5.55	2-1/4-28	14.1	7.88	0.19
30	UC206	30	62	38.1	19	1	15.9	22.2	5.5	2-M6 X 1	19.5	11.3	0.31
31.75	UC207-20	31.75	72	42.9	20	1.1	17.5	25.4	6.5	2-5/16-24	25.6	15.3	0.5
35	UC207	35	72	42.9	20	1.1	17.5	25.4	7	2-M8 X 1	25.7	15.3	0.5
38.1	UC208-24	38.1	80	49.2	21	1.1	19	30.2	8	2-5/16-24	29.5	18.1	0.68
40	UC208	40	80	49.2	21	1.1	19	30.2	8	2-M8 X 1	29.5	18.1	0.68
45	UC209	45	85	49.2	22	1.1	19	30.2	8	2-M8 X 1.0	31.6	20.6	0.68
50	UC210	50	90	51.6	23	1.1	19	32.6	10	2-M10 X 1.25	35	23.2	0.78
50.5	UC211-32	50.8	100	55.6	24	1.5	22.2	33.4	10	2-3/8-24	43.5	29.2	1.22
55	UC211	55	100	55.6	24	1.5	22.2	33.4	10	2-M10 X 1.25	43.5	29.2	1.22
60	UC212	60	110	65.1	26	1.5	25.4	39.7	10	2-M10 X 1.25	47.7	32.9	1.52
63.5	UC213-40	63.5	120	65.1	27	1.5	25.4	39.7	10	2-3/8-24	57.5	40	1.9
65	UC213	65	120	65.1	27	1.5	25.4	39.7	10	2-M10 X 1.25	57.5	40	1.9

● Take-up units cast housing
Set screw type

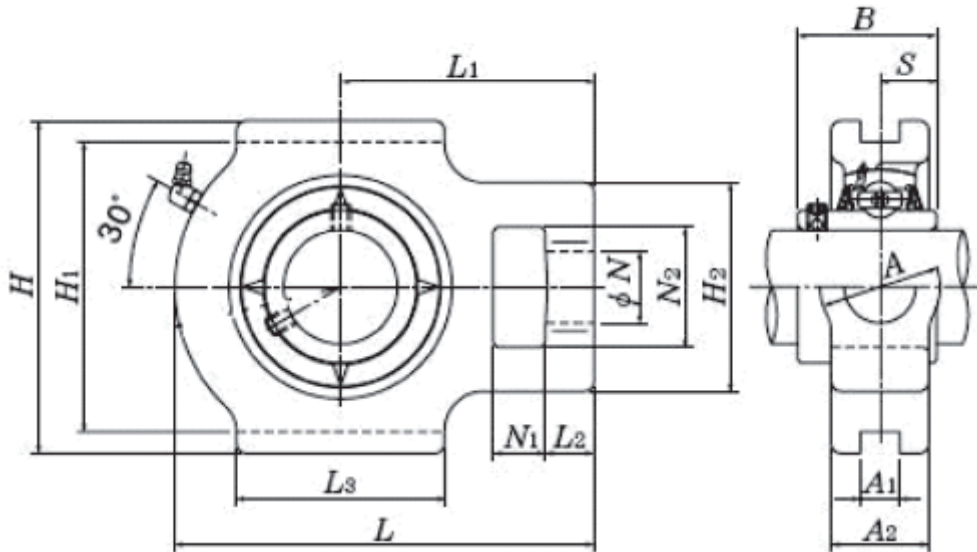

Shaft Dia	Unit No.	N ₁	L ₂	H ₂	N ₂	N	L ₃	A ₁	H ₁	H	L	A ₂	A	L ₁	B	S	Mass (Kg.)
28.575	UCT206-18	16	10	56	37	22	57	12	89	102	113	27	37	70	38.1	15.9	1.05
30	UCT206	16	10	56	37	22	57	12	89	102	113	27	37	70	38.1	15.9	1.05
31.75	UCT206-20	16	10	56	37	22	57	12	89	102	113	27	37	70	38.1	15.9	1.05
	UCT207-20	16	13	64	37	22	64	12	89	102	129	28	37	78	42.9	17.5	1.66
35	UCT207	16	13	64	37	22	64	12	89	102	129	28	37	78	42.9	17.5	1.64
44.45	UCT209-28	19	16	83	49	29	83	16	102	117	144	34	49	87	49.2	19	2.33
45	UCT209	19	16	83	49	29	83	16	102	117	144	34	49	87	49.2	19	2.3
50	UCT210	19	16	83	49	29	86	16	102	117	149	34	49	90	51.6	19	2.5
50.8	UCT211-32	25	19	102	64	35	95	22	130	146	171	36	64	106	55.6	22.2	3.35
55	UCT211	25	19	102	64	35	95	22	130	146	171	36	64	106	55.6	22.2	3.3

● Flanged units cast housing
Set screw type

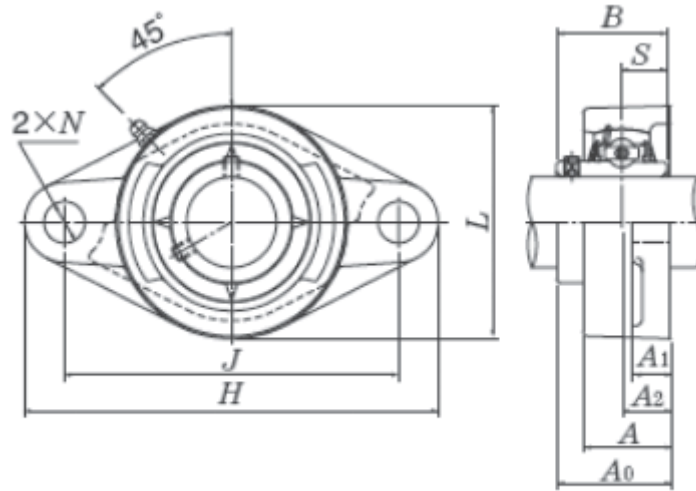

Shaft Dia	Unit No.	L	J	A ₂	A ₁	A	N	A ₀	B	S	Mass (Kg.)
25	UCF205	95	70	16	13	27	12	35.7	34.1	14.3	0.7
28.575	UCF206-18	108	83	18	14	31	12	40.2	38.1	15.9	0.99
30	UCF206	108	83	18	14	31	12	40.2	38.1	15.9	0.99
35	UCF207	117	92	19	16	34	14	44.4	42.9	17.5	1.31
40	UCF208	130	102	21	16	36	16	51.2	49.2	19	1.7
45	UCF209	137	105	22	18	38	16	52.2	49.2	19	1.88
50	UCF210	143	111	22	18	40	16	54.6	51.6	19	2.39
55	UCF211	162	130	25	20	43	19	58.4	55.6	22.2	3.18

● Flanged units cast housing
Set screw type

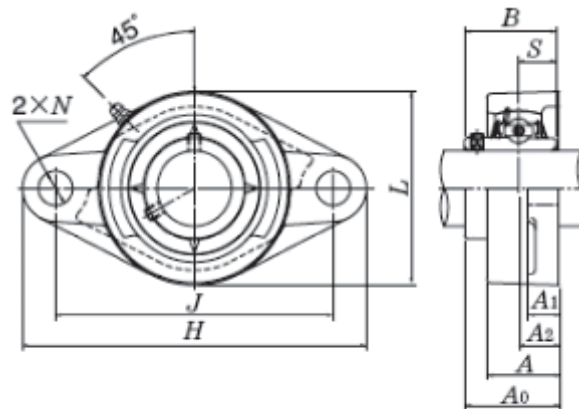

Shaft Dia	Unit NO.	H	J	A ₂	A ₁	A	N	L	A ₀	B	S	Mass (Kg.)
20	UCFL204	113	90	15	11	25.5	12	59	33.3	31	12.7	0.41
25	UCFL205	129	99	16	13	27	16	68	35.7	34.1	14.3	0.59
25.4	UCFL205-16	129	99	16	13	27	16	68	35.7	34.1	14.3	0.59
28.575	UCFL206-18	147	117	18	13	31	16	79	40.2	38.1	15.9	0.99
30	UCFL206-18	147	117	18	13	31	16	79	40.2	38.1	15.9	0.99
31.75	UCFL207-20	161	130	19	15	35	16	90	44.4	42.9	17.5	1.2
35	UCFL207	161	130	19	15	35	16	90	44.4	42.9	17.5	1.2
38.1	UCFL208-24	176	144	21	15	36	16	102	51.2	49.2	19	1.44
40	UCFL208	176	144	21	15	36	16	102	51.2	49.2	19	1.44
50	UCFL210	200	157	22	15	40	19	116	54.6	51.6	19	2.06
60	UCFL212	251	202	29	18	48	23	142	68.7	65.1	25.4	2.06

● SINGLE ROW CYLINDRICAL ROLLER BEARINGS (Metric Series)

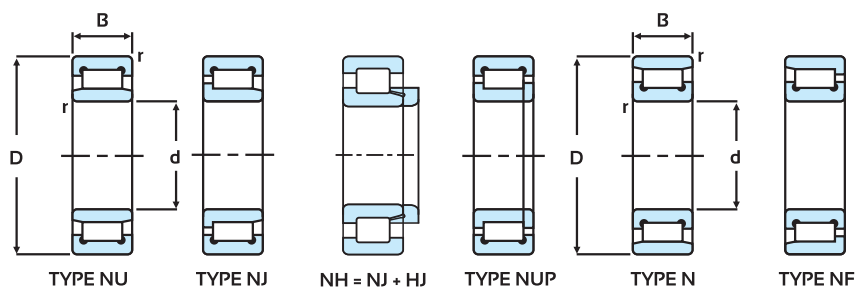

Boundary Dimension (mm)				Basic Load Rating (N)		Basic Load Rating (kgf)		Bearing Number	Mass Kg. (Approx.)	
d	D	B	r	Dynamic Cr	Static Cor	Dynamic Cr	Static Cor			
22	58	17	1.5	32300	37700	3293	3843	22X58X17	0.240	
	52	15	1.0	29300	27700	2987	2824	NU205E	0.130	
25	52	15	1.0	29300	27700	2987	2824	NJ205	0.137	
	52	15	0.6	29090	28400	2965	2895	N205E	0.210	
	52	15	0.6	29300	27700	2987	2824	NUP205E	0.140	
	52	18	1.0	32200	29600	3282	3017	NJ2205E	0.200	
	62	17	1.1	41500	37500	4230	3823	NJ305E	0.245	
	62	17	1.1	29200	25200	2977	2569	NU305	0.230	
	62	17	1.5	49800	47900	5076	4883	NJK305*	0.245	
	62	17	1.1	29200	25200	2977	2569	NJ305	0.240	
	62	17	1.1	29200	25200	2977	2569	N305	0.230	
	62	17	1.1	41500	37500	4230	3823	NU305E	0.386	
	62	24	1.1	56900	56100	5800	5719	NJ2305E	0.424	
	62	24	1.1	59840	59900	6100	6106	NU2305E	0.350	
	30	55	13	1.0	19600	19500	1998	1988	NUP1006	0.137
		58	17	1.5	32300	37700	3293	3843	30X58X17	0.190
61.935		19.05	3.17/1.5	51300	57700	5229	5882	CR30	0.300	
62		20	1.0	43300	38200	4414	3894	NJ2206EF	0.300	
72		19	1.1	69000	68000	7034	6932	NUP306EN	0.360	
72		19	2.0	51700	48400	5270	4934	N306EF	0.350	
80		22	4.0	71600	68100	7299	6942	NI274	0.720	
80		26	1.5	92000	108000	9378	11009	NI302	0.780	
72		17	1.1	60200	63200	6137	6442	NJ207EF	0.300	
72		23	1.1	61400	65600	6259	6687	NJ2207E	0.460	
35	80	21	1.5	46400	43000	4730	4383	N307	0.464	
	80	21	1.1/1.5	16400	43000	1672	4383	NJ307/J	0.487	
	80	21	1.5/4	72900	80300	7431	8186	NI076	0.530	
	80	21	1.5	69000	68000	7034	6932	NJ307EF	0.480	
	80	23	1.0	72300	77600	7370	7910	NU307ENS	0.570	
	80	26	1.5	94600	112300	9643	11448	MUB7307	0.674	
	90	23	2.0	102200	104900	10418	10693	NI242	0.781	
	80	18	1.1	43700	42900	4455	4373	N208	0.372	
40	80	18	1.1	55600	55400	5668	5647	NUP208E	0.384	
	80	18	1.1	55600	55400	5668	5647	NJ208	0.386	
	80	18	1.1	55600	55400	5668	5647	NU208	0.377	
	80	18	1.1	43700	42900	4455	4373	NH208/J	0.380	
	80	18	1.1	43700	42900	4455	4373	NUP208/J	0.340	
	80	23	1.1	72300	77600	7370	7910	NU2208E	0.538	
	80	23	1.1	76300	83200	7778	8481	NU2208E	0.480	
	80	23	1.1	76300	83200	7778	8481	NJ2208E	0.480	
	90	23	1.5	68300	66000	6962	6728	N308	0.643	
	90	23	4.0	102200	104900	10418	10693	WUB61308UM	0.730	
	90	23	1.5	82800	81300	8440	8287	NJ308E	0.760	
	90	23	2.5	80400	78000	8196	7951	NF308E/C3	0.760	

* Full Complement Roller Bearing

● SINGLE ROW CYLINDRICAL ROLLER BEARINGS (Metric Series)

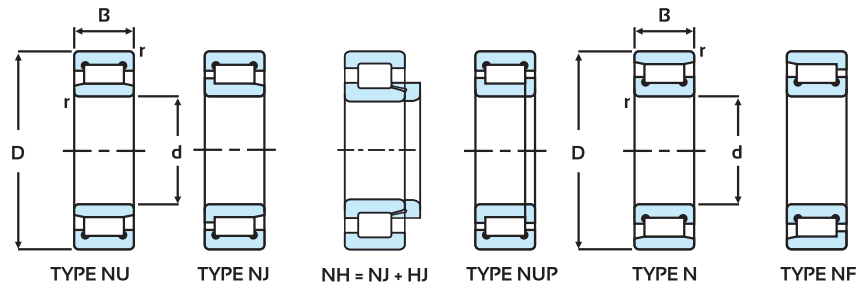

Boundary Dimension (mm)				Basic Load Rating (N)		Basic Load Rating (kgf)		Bearing Number	Mass Kg. (Approx.)
d	D	B	r	Dynamic Cr	Static Cor	Dynamic Cr	Static Cor		
45	85	19	1.1	63000	66500	6422	6779	NUP209E	0.504
	85	19	1.1	63000	66500	6422	6779	NJ209E	0.493
	85	23	1.1	79800	90200	8135	9195	NU2209EN	0.540
	100	25	1.5	73800	71000	7523	7238	NU309	0.857
	100	25	1.5	73800	71000	7523	7238	NU309N	0.845
	100	25	1.5	73800	71000	7523	7238	NF309	0.870
	100	25	1.5	73800	71000	7523	7238	NJ309	0.886
	100	25	1.5	73800	71000	7523	7238	NUP309N	0.898
	100	25	1.5	73800	71000	7523	7238	NJ309VN	0.919
	100	25	1.5	100500	102400	10245	10438	NU309E	0.890
	100	25	1.5	100500	102400	10245	10438	NU309EN	0.890
	100	25	1.0	100500	102400	10245	10438	NUP309E	0.888
	100	25	2.5	102400	105100	10438	10714	NUP309V	0.948
	100	25	1.5	97400	98300	9929	10020	NUP309EM	0.940
100	36	2.0	157900	176300	16096	17971	WUB1304	1.350	
49.93	80	15	0.6	45100	53900	4597	5494	CR50	0.280
50	90	20	1.1	48100	50900	4903	5189	NJ210E	0.560
	90	23	1.1	64100	73600	6534	7503	NH2210	0.648
	110	27	2.0	86900	86200	8858	8787	N310	1.116
	110	27	2.0	86900	86200	8858	8787	NUP310N	1.186
	110	27	2.0	86900	86200	8858	8787	NU310	1.190
	110	27	2.0	86900	86200	8858	8787	NJ310	1.140
	110	27	2.0	86900	86200	8858	8787	NUP310N	1.195
55	100	21	1.5	57900	62200	5902	6340	NU211	0.638
	100	21	1.5	57900	62200	5902	6340	NJ211	0.652
	120	29	2.0	136000	141000	13863	14373	NJ311EF	1.500
60	110	22	1.5	85700	82300	8736	8389	NUP212E	0.966
	110	26	1.0	117800	136900	12008	13955	N1072	1.140
	130	31	2.1	150700	158600	15362	16167	N312EM	1.800
	130	31	3.5	158700	150600	16177	15352	N312EF(2312)	1.800
65	140	33	2.1	181800	193400	18532	19715	NUP313E	2.370
	140	33	2.1	181800	193400	18532	19715	N313EM	2.300
70	150	35	2.1	158000	168000	16106	17125	N314	2.150
	150	35	2.1	184700	171600	18828	17492	N314EF	2.150
75	160	37	2.1	238500	260800	24312	26585	NUP315E	3.450
90	190	64	3.0	450000	530000	45872	54027	N2318E	8.000
	190	43	3.0	311900	349400	31794	35617	N318EC3	5.200
95	200	45	3.0	331000	381000	33741	38838	NU319EMC3	7.500
100	180	34	2.1	247400	302800	25219	30866	NU220E	3.500
	215	47	3.0	315000	395000	32110	40265	NU320M	8.750
	215	47	3.0	320000	397000	32620	40469	N320MC3	8.500

● SINGLE ROW CYLINDRICAL ROLLER BEARINGS (Metric Series)

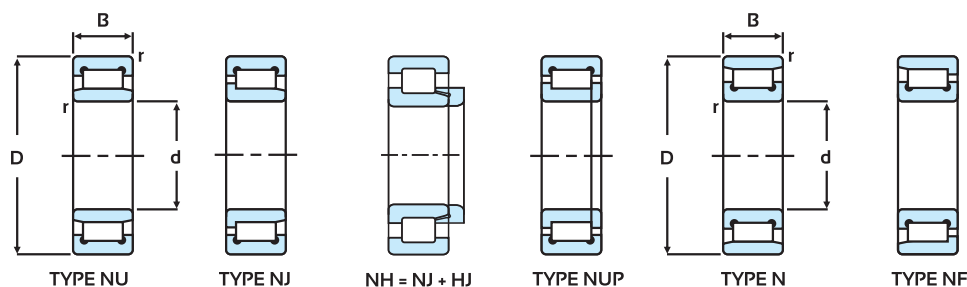

Boundary Dimension (mm)				Basic Load Rating (N)		Basic Load Rating (kgf)		Bearing Number	Mass Kg. (Approx.)
d	D	B	r	Dynamic Cr	Static Cor	Dynamic Cr	Static Cor		
105	225	49	3.0	364000	423000	37105	43119	N321M	9.810
	225	49	3.0	364000	423000	37105	43119	NU321M	9.910
110	200	38	2.1	255000	315000	26020	32142	NU222M	5.500
	240	50	3.0	380000	420000	38736	42814	NU322M	11.600
120	215	40	2.1	288000	365000	29358	37207	NU224MC3	6.300
	260	55	3.0	490000	645000	50000	65816	NU324M	15.500
	260	55	3.0	540000	620000	55102	63265	NJ324E	15.000
130	230	40	3.0	295000	385000	30071	39246	NU226M	7.300
	230	79.4	5.0	525400	776100	53558	79113	NU5226M	14.000
	230	64	3.0	530000	735000	54081	75000	NU2226E	12.200
	280	58	4.0	561000	671000	57244	68469	NU326M	17.000
140	250	42	3.0	345000	450000	35168	45872	NU228M	9.300
	270	45	3.0	405000	550000	41284	56065	NU230M	11.800
150	270	88.9	6.0	728800	1103900	74292	112528	NU5230M	22.000
	280	93	3.0	790000	1180000	80530	120285	"72727 (With Sleeve AHX3228)	32.000
160	320	65	4.0	800000	985000	81549	100407	NU330	25.600
	340	68	4.0	685000	970000	69827	98879	NU332MC3	31.000
	340	114	4.0	1330000	1840000	135714	187755	NU2332E	53.000
	290	80	3.0	940000	1170000	95918	119266	NU2232E	24.000
	240	38	2.1	235000	335000	23979	34183	NU1032C3	6.200
	340	68	4.0	710000	950000	72448	96938	N332M	30.400
	290	48	3.0	500000	664000	51020	67755	NU232M	14.400
170	360	72	5.0	800000	1020000	81549	103976	N334	38.700
	310	52	4.0	600000	790000	61224	80612	N234M	18.000
	310	52	4.0	610000	850000	62181	86646	NU234MC3	19.500
180	320	108	3.0	987900	1552600	100703	158267	NU5236M	37.000
	320	52	4.0	525000	735000	53571	75000	NU236M	18.500
	380	75	4.0	917000	117500	93476	11978	NJ336E	43.500
	280	46	2.1	340000	465000	34693	47448	NU1036	11.000
	380	75	4.0	917000	1175000	93476	119776	NU336	43.000
190	400	78	5.0	975000	1260000	99388	128440	NU338	49.500
200	360	120.65	6.0	1337000	2229000	136290	227217	NU5240	53.700
	360	120.65	6.0	1409000	2391000	143629	243731	NU5240M	57.250
	310	51	2.1	400000	590000	40816	60204	NU1040M	13.800
	360	58	4.0	630000	880000	64220	89704	NU240	28.000
	420	138	5.0	1900000	2620000	193679	267074	NU2340EM	93.300

*Full Complement Roller Bearing

● SINGLE ROW CYLINDRICAL ROLLER BEARINGS (Metric Series)

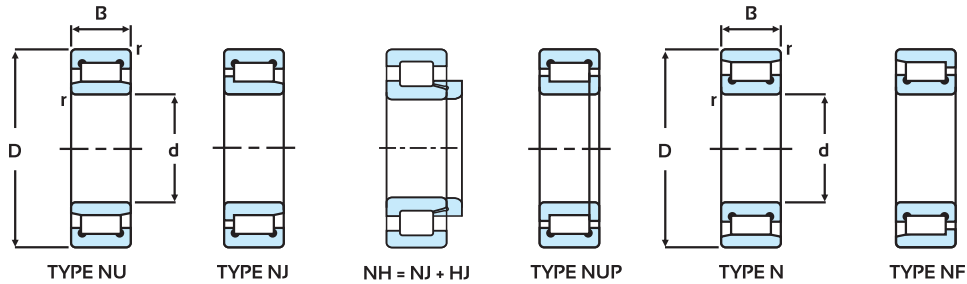

Boundary Dimension (mm)				Basic Load Rating (N)		Basic Load Rating (kgf)		Bearing Number	Mass Kg. (Approx.)
d	D	B	r	Dynamic Cr	Static Cor	Dynamic Cr	Static Cor		
210	340	95.2	6.0	955000	1835000	97448	187244	NU5044M	31.000
	350	98.4	2.5	953500	1649000	97197	168094	NI263	35.000
220	400	65	4.0	799000	1150000	81448	117227	NU244M	38.000
	400	65	4.0	1038000	1264000	105918	128979	NUP244	38.500
	460	88	5.0	1223000	1392000	124668	141896	NI134	70.770
240	440	146.05	4.0	2617000	4298000	266769	438124	NU5248	100.000
	360	56	3.0	534000	832000	54434	8645	NU1048M	19.700
	390	108	3.0	1446000	2180000	147400	222222	NI133	50.290
260	400	65	4.0	655000	1090000	66836	111224	NU1052M	30.200
	360	46	2.1	370200	598300	37737	60988	NF1952	14.050
280	500	165.1	4.0	2915500	5238800	297197	534027	NU5256	139.000
	380	46	2.1	384600	642900	39204	65535	NU1956	14.960
	380	46	2.1	384600	642900	39204	65535	NF1956	14.960
	500	165.1	4.0	2970000	5353000	302752	545667	NI112	144.740
300	460	74	4.0	850000	1350000	86734	137755	NU1060E	44.500
320	440	56	3.0	625000	1100000	63710	112130	NU1964	25.310
340	620	165	6.0	2880000	4650000	293577	474006	NU2268	28.560
380	680	240	6.0	4300000	7650000	438328	779816	NU3276	376.100
	680	175	6.0	3332000	5790000	339653	590214	NU2276	274.240
	680	177	6.0	3350000	5800000	341836	591836	NI205	281.750
400	600	90	5.0	1370000	2320000	139653	236493	NU1080	91.000
460	760	240	7.5	5600000	10400000	571428	1061224	NU3192M	467.000
	680	100	6.0	1850000	3360000	188775	342857	NU1092M	124.700
480	790	248	7.5	5900000	11000000	602040	1122448	NU3196M	507.800
530	710	180	6.0	3244000	8129200	330683	828665	42629/530	220.000
600	830	150	6.0	2820000	6147000	287461	626605	327/600	245.000
670	980	308	10.0	7120000	10000000	725790	1019368	NI1009	780.000
700	930	160	8.0	2972800	6902500	303038	703619	327/700	300.000

● SINGLE ROW CYLINDRICAL ROLLER BEARINGS (Inch Series)

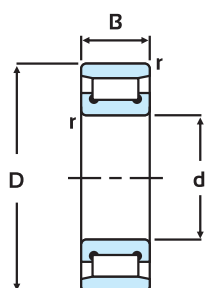

TYPE N

Boundary Dimension (mm)				Basic Load Rating (N)		Basic Load Rating (kgf)		Bearing Number	Mass Kg. (Apporox.)
d	D	B	r	Dynamic Cr	Static Cor	Dynamic Cr	Static Cor		
101.60	184.15	31.75	3.2	225000	270000	22936	27523	CRL32	3.800
107.95	190.5	31.75	3.2	235000	285000	23979	29081	CRL34	4.000
114.30	203.2	33.337	3.2	255000	315000	25994	32110	CRL36	4.600
	238.125	50.8	4.8	440000	505000	44852	51478	CRM36	11.000
127.00	228.6	34.925	3.2	288000	370000	29358	37717	CRL40	6.500
	254	50.8	4.8	465000	550000	47401	56065	CRM40	12.000
139.70	241.3	34.925	3.0	296000	390000	30204	39795	CRL44	7.200
390.53	579.973	190.5	4.0	3572000	6107000	364118	622528	N1113	207.250
469.90	698.5	139.7	6.0	3300000	6180000	336391	629969	N1050	190.000

● MULTI ROW CYLINDRICAL ROLLER BEARINGS

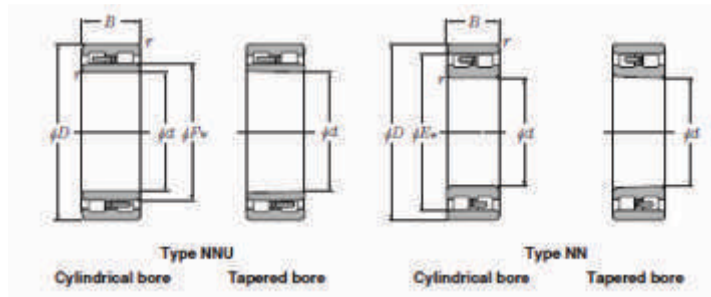

DOUBLE ROW CYLINDRICAL ROLLER BEARING

Boundary Dimension (mm)				Basic Load Rating (N)		Basic Load Rating (kgf)		Bearing Number	Mass Kg. (Approx.)
d	D	B	r	Dynamic Cr	Static Cor	Dynamic Cr	Static Cor		
120	180	46	2.0	225000	375000	22936	38226	NN3024K	4.020
	260	103	4.0	826000	1452000	84199	148012	NI081	31.850
130	200	52	2.0	305000	530000	31091	54027	NN3026K	5.340
130.06	300.02	171.6	3.0	1403000	2393600	143017	243996	549722	70.000
220	370	150	4.0	1600000	2800000	163099	285423	NNU4144MW33	66.000
280	380	100	3.5	697800	908000	71131	92559	NNU4956	33.290
	440	135	4.0	1770000	3360000	180612	342857	132756	99.500
320	480	160	4.0	2050000	4150000	208970	423038	NNU4064MW33	103.000
460	680	218	9.0	3750000	8560000	382263	872579	4202192	240.000
710	950	243	6.0	5734000	15165000	584506	1545872	42629/710	495.000

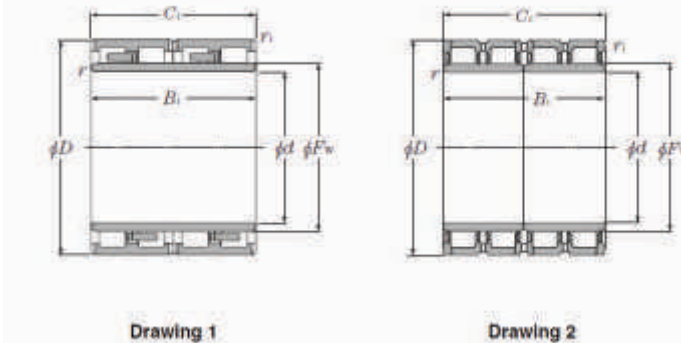

FOUR ROW CYLINDRICAL ROLLER BEARING

Boundary Dimension (mm)				Basic Load Rating (N)		Basic Load Rating (kgf)		Bearing Number	Mass Kg. (Approx.)
d	D	B	r	Dynamic Cr	Static Cor	Dynamic Cr	Static Cor		
100	140	80	1.5	356000	503000	36290	51274	NI105	3.610
120	165	90	1.5	519000	813000	52905	82875	NI106	5.560
150	230	156	2.5	865000	1550000	88175	158002	"4R3040 (313891)"	24.500
160	230	168	2.0	890000	2150000	90816	219387	315189	24.000
200	290	192	2.1	1500000	3200000	153061	326530	313811	41.000
230	330	206	2.1	1870000	4000000	190816	408163	313824	58.000
280	390	220	3.0	2200000	5000000	224489	510204	313822	81.500
340	480	350	1.5	4570000	11200000	466326	1142857	314485	207.000
530	780	570	6.0	12500000	32500000	1274209	3312945	4R10602	1010.000
650	900	650	7.5	17205000	41510000	1753823	4231397	NI210	1246.000
	920	670	4.0	16800000	46500000	1712538	4740061	4R13005	1500.000
698	1000	715	4.0	23205000	53005000	2365443	5403160	NI227	1800.000
710	1000	715	4.0	23205009	53005000	2365444	5403160	4R14205	1800.000
950	1360	975	6.0	34100000	100000000	3479591	10204081	319862	5000.000

● SPECIAL CYLINDRICAL ROLLER BEARING

INCH SERIES

Boundary Dimension (mm)				Basic Load Rating (N)		Basic Load Rating (kgf)		Bearing Number	Mass Kg. (Apporox.)
d	D	B	r	Dynamic Cr	Static Cor	Dynamic Cr	Static Cor		
26.993	50.782	17.4625	1.6	-	-	-	-	L3782	0.660
35	62	17	1.1	41500	37500	4230	3823	RNU305	0.187
58.5	100	25	2.4	73800	71000	7523	7238	RNU309	0.660
66.5	100	21	1.1	58000	62500	5912	6371	RNU211	0.450
120	260	103	4.0	826000	1452000	84200	148012	NI081	31.850

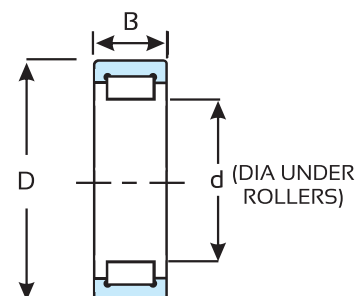

INCH SERIES

Boundary Dimension (mm)				Basic Load Rating (N)		Basic Load Rating (kgf)		Bearing Number	Mass Kg. (Apporox.)
d	D	B	r	Dynamic Cr	Static Cor	Dynamic Cr	Static Cor		
31.75	79.35	22.225	1.1	57500	53600	5861	5464	NI004	0.510

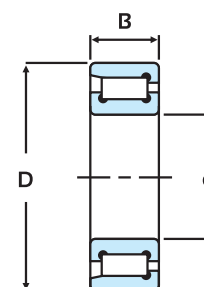

INCH SERIES

Boundary Dimension (mm)				Basic Load Rating (N)		Basic Load Rating (kgf)		Bearing Number	Mass Kg. (Apporox.)
d	D	B	r	Dynamic Cr	Static Cor	Dynamic Cr	Static Cor		
25.4	53.962	28.575	1.1	60000	61800	6116	6300	LO64	0.263

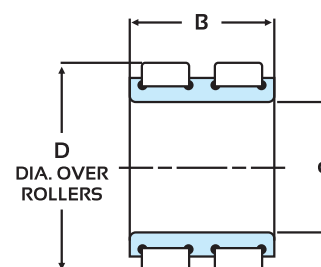

Boundary Dimension (mm)				Basic Load Rating (N)		Basic Load Rating (kgf)		Bearing Number	Mass Kg. (Apporox.)
d	D	B	r	Dynamic Cr	Static Cor	Dynamic Cr	Static Cor		
680	742.5	300	8	-	-	-	-	NI065	161.83
820	903	400	10	-	-	-	-	NI084	348.02

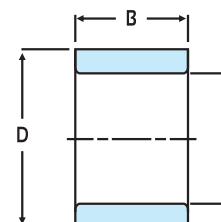

● SPECIAL CYLINDRICAL ROLLER BEARINGS

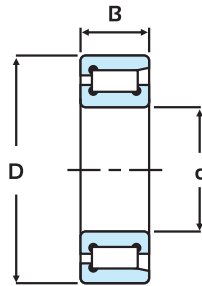

METRIC SERIES

Boundary Dimension (mm)				Basic Load Rating (N)		Basic Load Rating (kgf)		Bearing Number	Mass Kg. (Apporox.)
d	D	B	r	Dynamic Cr	Static Cor	Dynamic Cr	Static Cor		
100	200	67	4.0	393700	495600	40133	50520	WJ100X200W	10.920
	200	67	4.0	393700	495600	40133	50520	WJ100X200	10.340
116	220	60	4.0	374000	539900	38124	55036	RB5033	9.830
	220	60	1.6	374000	539900	38124	55036	RB5034	10.890
118	215	60	1.6	374000	539900	38124	55036	RB5070	10.000
	215	60	4.0	374000	539900	38124	55036	RB5069	10.325
	220	60	4.0	383000	550000	39042	56065	RB5001	10.600
120	220	60	1.6	383000	550000	39042	56065	RB5002	10.600
	215	60	4.0	374000	539900	38124	55036	L6179	9.550
	220	60	4.0	383000	550000	39042	56065	L5063	10.420
	240	80	4.0	565000	757000	57594	77166	WJPI20X240P	15.967
	215	60	1.6	374000	539900	38124	55036	L6180	9.660
	220	60	1.6	383000	550000	39042	56065	L5064	10.530
	240	80	1.6	550900	738100	56157	75240	WJPI20X240P	17.770
126	240	80	4.0	446000	591000	45464	60245	RB5006	28.080
	240	80	1.6	524300	746700	53445	76116	RB5059	17.480
	240	80	4.0	524300	746064	53445	76051	RB5058	17.030
128	240	80	4.0	480900	669839	49021	68281	NBR102	10.920
	240	80	1.6	480900	668600	49021	68155	NBR101	15.753
	240	80	1.6	524300	746700	53445	76116	RB5057	17.190
	240	80	4.0	524300	746200	53445	76065	RB5056	16.740
130	240	80	4.0	480900	669839	49021	68281	WJPI30X240	14.950
	240	80	4.0	514000	726000	52396	74006	WJPI30X240E	17.000
	240	80	1.6	480900	668600	49021	68155	WJPI30X240P	14.950
	240	85	1.6	480900	668600	49021	68155	WJPI30X240P	14.950
	240	85	1.6	524300	746700	53445	76116	WJPI30X240PE	17.000
	240	80	1.6	524300	746700	53445	76116	WJPI30X240PE	17.000
144.5	245	72	4.0	491000	721800	50051	73578	RB5024	15.035
	245	80	4.0	544300	831300	55484	84740	RB5047	15.700
	245	72	4.0	486834	720133	49626	73408	RB5023	14.400
	245	80	4.0	544300	831260	55484	84736	RB5046	15.485
	270	80	2.0	641000	932000	65341	95005	RB5043	20.760
148	270	80	1.5	641000	932000	65341	95005	RB5062	20.420
	270	80	4.0	637500	926100	64985	94404	RB5063	10.600
	270	80	1.6	637500	926100	64985	94404	RB5064	10.560
	270	80	2.0	641000	932000	65341	95005	RB5044	20.810
	270	80	2.0	641000	932000	65341	95005	L6205	20.490
	300	102	5.0	960100	1373700	97870	140031	WJPI30X300P	35.320
150	270	80	2.0	641000	932000	65341	95005	L6204	20.440
	300	102	5.0	960100	1373700	97870	140031	WJPI50X300	35.030
	270	80	2.0	641000	932000	65341	95005	RB5020	20.230
	270	80	2.0	641000	932000	65341	95005	RB5021	22.690
	270	80	2.0	641000	932000	65341	95005	RB5022	22.440
200	360	236	1.6	1567500	2741500	159786	279460	L6207	60.180
	360	98	4.0	912774	1369925	93045	139646	L6019	44.350

● SPECIAL CYLINDRICAL ROLLER BEARINGS

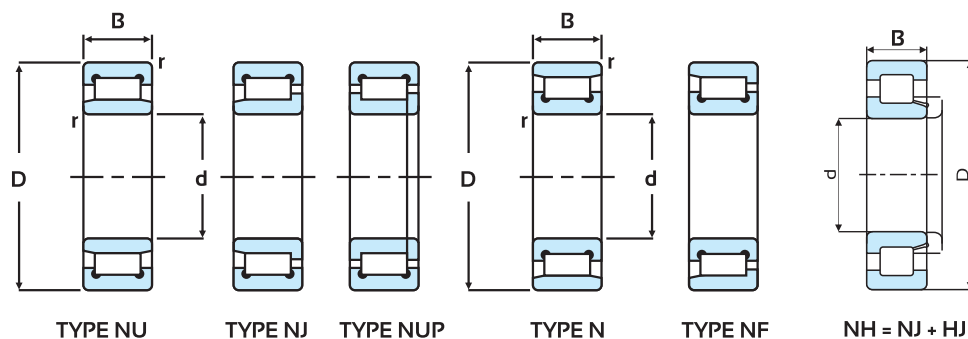

FOR TRACTION MOTOR APPLICATION
METRIC SERIES

Boundary Dimension (mm)				Basic Load Rating (N)		Basic Load Rating (kgf)		Bearing Number	Mass Kg. (Approx.)
d	D	B	r	Dynamic Cr	Static Cor	Dynamic Cr	Static Cor		
90	190	43	3.0	315000	355000	32110	36188	NH318	6.956
	190	43	3.0	298000	327000	30377	33333	NUP318	6.404
100	190	43	3.0	298000	327000	30377	33333	NU318	5.895
	215	47	3.0	380000	425000	38736	43323	NU320	8.750
120	215	47	3.0	380000	425000	38736	43323	NH320*	9.849
	260	55	4.0	475000	550000	48420	56065	NH324	17.564
	260	55	4.0	475000	550000	48420	56065	NJ324	16.000
	260	55	4.0	475000	550000	48420	56065	NU324	15.500
130	280	58	4.0	620000	795000	63201	81040	NU326	19.465
140	300	62	4.0	671000	810000	68400	82569	NU328	23.200
150	320	65	4.0	800000	985000	81549	100408	NU330*	27.729
180	380	75	4.0	905000	1150000	92253	117227	NU336	43.000

1. All Bearings are made with Riveted Brass Cage.
2. *Marked bearings are also available with Rivetless Brass Cage.

● DOUBLE ROW CYLINDRICAL ROLLER SEALED UNIT

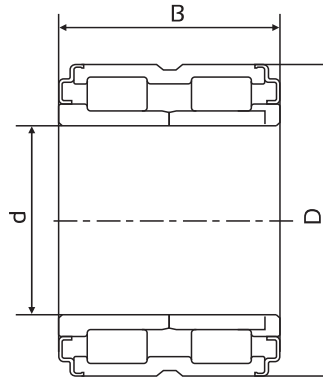

TYPE - VII

Boundary Dimension (mm)				Basic Load Rating (N)		Basic Load Rating (kgf)		Bearing Number	Mass Kg. (Approx.)
d	D	B	r	Dynamic Cr	Static Cor	Dynamic Cr	Static Cor		
150	250	160	2.1	1014967	1799055	103462	183389	RB5080	33.271
150	270	174	1.2	1280000	2105866	130479	214665	RB5081	49.459

● SINGLE ROW TAPERED ROLLER BEARINGS (Inch Series)

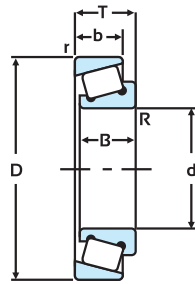

Boundary Dimension (mm)							Basic Load Rating (N)		Basic Load Rating (kgf)		Bearing Number	Mass Kg. (Approx.)
d	D	T	B	b	R	r	Dynamic Cr	Static Cor	Dynamic Cr	Static Cor		
15.875	42.862	14.288	14.288	9.525	1.5	1.5	18000	18000	1835	1835	I1590/I1520	0.101
17.462	39.878	13.843	14.605	10.668	1.3	1.3	22400	23000	2283	2345	LM11749/LM11710	0.081
19.05	45.237	15.494	16.637	12.065	1.3	1.3	29300	29900	2987	3048	LM11949/LM11910	0.119
21.43	49.225	18.034	19.05	14.288	1.3	1.3	40600	42300	4139	4312	MI2644/ MI2610	0.185
23.812	50.005	17.526	18.288	13.97	1.3	1.3	40600	42400	4139	4322	MI2649/MI2610	0.166
25.4	61.912	28.575	30.416	23.812	2.36	3.3	73600	78600	7503	8012	3659/3620	0.300
	57.15	19.431	19.431	14.732	1.6	1.6	42000	49000	4281	4995	M84548/ M84510	0.236
	62	19.05	20.638	14.288	1.3	1.3	42200	47800	4302	4873	15100S/15245	0.299
	63.5	20.638	20.638	15.875	1.3	1.5	42200	47800	4302	4873	15100S/15250X	0.225
	65.088	22.225	21.463	15.875	1.5	1.5	47800	52000	4873	5301	23100/23256	0.356
26.988	50.29	14.224	14.732	10.668	3.5	1.3	27800	32200	2834	3282	L44649/L44610	0.117
	57.15	19.845	19.355	15.875	3.5	1.5	46700	53400	4760	5443	1988/1922	0.216
28.575	62	18.161	19.05	14.288	3.5	1.3	42200	47800	4302	4873	15112R/15245	0.274
	73.025	22.225	22.225	17.462	0.8	3.3	60400	74200	6157	7564	O2872/O2820	0.477
29.985	62	19.05	20.638	14.288	1.3	1.3	42200	47800	4302	4873	15117/15245	0.275
30.162	64.292	21.433	21.433	16.67	1.6	1.6	51500	61400	5250	6259	M86649/M86610	0.336
	59.131	15.875	16.764	11.811	3.56	1.3	34500	41500	3517	4230	LM67048/LM67010	0.184
	62	18.161	19.05	14.288	3.5	1.3	42200	47800	4302	4873	15123/15245	0.225
31.75	62	19.05	20.638	14.288	3.5	1.3	42200	47800	4302	4873	15125/15245	0.239
	68.263	22.225	22.225	17.463	3.5	1.5	50600	57100	5158	5821	O2475/O2420	0.379
	69.012	19.845	19.583	15.875	3.5	1.3	45900	54800	4679	5586	14125A/14276	0.350
	72.626	30.162	29.997	23.812	1.5	3.3	78500	88700	8002	9042	3188S/3120	0.574
33.338	68.262	22.225	22.225	17.462	0.8	1.6	57000	72000	5810	7339	M88048/M88010	0.382
	69.012	19.845	19.583	15.875	0.8	1.3	45900	54800	4679	5586	14131/14276	0.334
	76.2	29.37	28.575	23.02	1.5	3.3	78500	106300	8002	10836	HM89446X1XA/ HM89410F	0.644
	76.2	29.37	28.575	23.02	3.5	3.3	78500	106300	8002	10836	HM89446/ HM89410	0.641
34.925	65.088	18.034	18.288	13.97	3.5	1.3	50000	61000	5097	6218	LM48548/LM48510	0.250
	69.012	19.845	19.583	15.875	1.5	1.3	45900	54800	4679	5586	14137A/14276	0.319
	72.233	25.4	25.4	19.842	2.4	2.4	65000	84500	6626	8614	HM88694/ HM88610	0.498
	73.025	23.813	24.608	19.05	1.5	0.8	71400	85500	7278	8716	25877/25821	0.444
	73.025	23.813	24.608	19.05	1.5	2.3	71400	85500	7278	8716	25877/25820	0.444
	76.2	29.37	28.575	23.812	1.5	3.3	80700	96900	8226	9878	31594/31250	0.619
34.989	79.375	29.37	29.771	23.812	3.5	3.3	87000	104600	8869	10663	3490/3420	0.679
	79.985	32.751	30.925	25	2.5	2.5	87000	104300	8869	10632	3478X/3424S	0.765
	82.931	23.812	25.4	19.05	0.8	0.8	76700	98400	7819	10031	25572/25520	0.645
	65.088	18.034	18.288	13.97	3.5	1.3	42600	55700	4343	5678	LM29749/LM29710	0.232
38.1	79.375	29.37	29.771	23.812	3.5	3.2	91000	111200	9276	11335	3490/3420	0.675
	65.107	19.812	20	15.748	2.3	1.3	46600	68300	4750	6962	NI261XI/ NI261FPXI	0.267
	88.5	26.988	29.083	22.225	3.6	1.6	98186	111678	10009	11384	418/414	0.810
39.688	76.2	23.812	25.654	19.05	3.5	0.8	77000	97000	7849	9888	TMB2789/2729	0.477
	76.2	23.812	25.654	19.05	3.6	0.8	73000	92000	7441	9378	2789/2729	0.477

● SINGLE ROW TAPERED ROLLER BEARINGS (Inch Series)

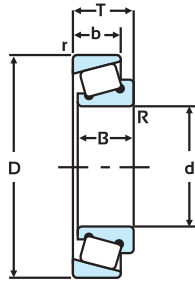

Boundary Dimension (mm)							Basic Load Rating (N)		Basic Load Rating (kgf)		Bearing Number	Mass Kg. (Approx.)
d	D	T	B	b	R	r	Dynamic Cr	Static Cor	Dynamic Cr	Static Cor		
40	80	21	22.403	17.826	3.5	1.3	69000	76300	7034	7778	344/332	0.469
40.988	67.975	17.5	18	13.5	3.5	1.5	45300	61400	4618	6259	LM300849X/LM300811	0.239
41.275	82.55	26.543	25.654	20.193	3.5	3.3	84000	111500	8563	11366	M802048/M802011	0.619
	73.431	19.558	19.812	14.732	3.6	0.8	58235	73160	5936	7458	LM501349/LM501310	0.333
	76.2	22.225	23.017	17.462	3.6	0.8	66312	83329	6760	8494	24780/24720	0.423
42.875	87.312	30.162	30.886	23.812	1.5	3.5	97000	122900	9888	12528	3585/3525	0.834
	82.931	26.988	25.4	22.225	3.5	2.3	76800	98200	7829	10010	25577/25523	0.615
	95.25	27.783	28.575	22.225	0.8	2.3	108900	141600	11101	14434	33885/33821	0.976
44.45	92.075	30.163	29.37	23.02	3.6	3.3	99000	125000	10092	12742	HM803149/HM803112	0.920
	93.264	30.162	30.302	23.812	3.56	3.3	102000	134000	10398	13660	3782/3720	0.961
	95.25	30.958	28.875	22.225	3.5	0.8	98400	11900	10031	1213	HM903249/HM303210	1.838
	111.125	38.1	36.975	30.162	3.5	3.3	143300	180500	14608	18400	535/532A	1.838
45.242	112.713	30.133	26.909	20.638	0.8	3.3	106500	140500	10856	14322	55176C/55443	1.500
	77.788	21.43	19.842	16.667	3.5	0.8	56900	72600	5800	7401	LM603049/LM603012	0.381
	77.788	19.842	19.842	15.08	3.5	0.8	56900	72700	5800	7411	LM603049/LM603011	0.358
45.618	82.931	23.812	25.4	19.05	3.5	2.3	76700	98400	7819	10031	25590/25520	0.543
	88.9	20.638	22.225	16.513	3.5	1.3	77800	93800	7931	9562	3695/362A	0.548
	95.25	30.162	29.37	23.02	3.5	3.3	109500	148700	11162	15158	HM804846/HM804810	0.773
49.213	103.18	43.658	44.475	36.51	3.5	3.3	174000	232000	17737	23649	5395/5335	0.773
49.987	112.713	30.1875	26.909	20.638	3.5	3.3	106500	140500	10856	14322	55187C/55443	1.415
50	93.564	30.162	30.302	23.812	2.0	3.3	104000	139100	10601	14179	N1280/3720	0.862
50.8	93.264	30.162	30.302	23.812	3.56	3.3	102000	134000	10398	13660	3780XA/3720	0.840
	92.075	24.608	25.4	19.845	3.56	0.8	84600	116400	8624	11865	28580/28521	0.703
	93.264	30.162	30.302	23.812	3.56	3.3	102000	134000	10398	13660	3780/3720	0.618
	111.125	30.162	26.909	20.638	3.6	3.3	111000	149000	11315	15189	55200/55437	1.340
52.388	111.125	30.162	26.909	20.638	3.6	3.3	111000	149000	11315	15189	55206C/55437	1.310
	107.95	36.512	36.957	28.575	3.5	3.3	143300	180600	14608	18410	539/532X	1.450
53.975	114.981	65.085	26.909	44.445	2.30.50-Ch		178600	286900	18206	29246	55194/55452D	3.120
	123.825	36.512	32.791	25.4	3.5	3.3	157700	193000	16075	19674	72212C/72487	2.010
57.15	104.775	30.162	29.317	24.605	2.3	3.3	117000	155000	11927	15800	462A/453X	1.060
	112.712	30.162	30.162	23.813	8.0	3.3	151600	218700	15454	22294	39581/39520	1.315
59.985	109.985	29.751	28	23.813	2.4	1.5	117400	171600	11967	17492	"3977X/3922X(X32212)"	1.200
	134.983	35.862	30.925	21.948	3.5	3.5	144900	169400	14771	17268	HM911244/HM911216	2.423
60.325	100	25.4	25.4	19.845	3.6	3.3	95000	141000	9684	14373	28985/28921	0.750
	110	29.37	30.048	23.02	7.1	1.5	117400	171600	11967	17492	3982X/3927XA	1.100
	112.712	30.163	30.048	23.813	7.1	3.3	117400	171600	11967	17492	3982X/3920	1.214
	112.712	30.162	30.162	23.812	3.6	3.3	145000	203000	14781	20693	39585/39520	1.380
	119.985	32.751	30.914	26.949	2.3	0.8	151700	218500	15464	22273	39586/39528	1.500
63.5	122.238	38.1	38.354	29.718	7.1	1.5	190000	249200	19368	25403	HM212047/HM212010	1.933
	130	36.937	33.937	28	6.5	3.5	171500	211600	17482	21570	JHM513640/JHM513615	2.126
65	105	24	23	18.5	3.0	1.0	94000	128000	9582	13048	JLM710949C/JLM710910	0.750

● SINGLE ROW TAPERED ROLLER BEARINGS (Inch Series)

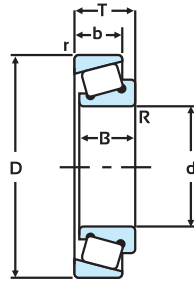

Boundary Dimension (mm)							Basic Load Rating (N)		Basic Load Rating (kgf)		Bearing Number	Mass Kg. (Approx.)
d	D	T	B	b	R	r	Dynamic Cr	Static Cor	Dynamic Cr	Static Cor		
65.088	135.755	53.975	56.007	44.45	3.5	3.3	265000	355900	27013	36279	6379/6320	3.598
66.675	123.825	38.1	36.678	30.162	3.6	3.3	161000	221000	16412	22528	559/552A	1.900
	110	22	21.996	18.824	3.6	1.3	86000	114000	8767	11621	3955/394A	0.784
	112.712	30.162	30.048	23.813	3.5	3.3	117400	171500	11967	17482	3984/3920	1.142
	122.238	38.1	38.354	29.718	3.56	3.3	187000	244000	19062	24873	HM212049/HM212011	1.860
68.262	110	22	21.996	18.824	2.3	1.3	86000	114000	8767	11621	399A/394A	0.759
69.85	120	29.794	29.007	24.237	3.5	2.0	134100	190000	13670	19368	482/472	1.320
	127	36.512	36.17	28.575	3.5	3.3	165300	232900	16850	23741	566/563	1.900
69.865	120	32.545	32.545	26.195	3.6	3.3	149722	219189	15262	22343	47487/47420	1.467
71.438	127	36.512	36.17	28.575	3.5	3.3	165300	232900	16850	23741	567A/563	1.850
	139.992	36.512	36.098	28.575	3.5	-	175400	26900	17880	2742	576 CONE ASSLY.	1.705
73.025	112.712	25.4	25.4	19.05	3.56	3.3	95500	151000	9735	15392	TMB29685/TMB29620	0.873
	127	36.512	36.17	28.575	3.5	3.3	165300	232900	16850	23741	567/563	1.825
76.2	149.225	53.975	54.229	44.45	9.65	3.3	288200	410500	29378	41845	6461A/6420	4.240
	127	30.162	31	22.225	3.5	3.3	137300	198400	13996	20224	42687/42620	1.460
80	140	35.25	33	28	3.0	3.0	186100	282200	18970	28767	M32216A/M32216E	2.192
82.55	139.992	36.512	36.098	28.575	3.5	3.2	173900	258000	17727	26300	580/572F	2.155
	136.525	30.162	29.769	22.225	3.5	3.3	13000	191900	1325	19562	495/493	2.020
	139.7	36.512	36.098	28.575	3.5	3.3	174300	258700	17768	26371	580/572X	2.138
	139.992	36.512	36.098	28.575	3.5	3.3	174300	258700	17768	26371	580/572	2.138
85	130	30	29	24	3.0	2.5	140000	223000	14271	22732	JM716648/JM716610	1.370
85.725	136.525	30.162	26.769	22.225	3.5	3.3	129100	190400	13160	19409	497/493	1.525
95	135	20	20	14	5.0	2.5	82392	146166	8399	14900	JL819349/JL819310	0.862
95.25	168.275	41.275	41.275	30.162	3.5	3.2	225100	347800	22946	35454	683/672	3.650
	152.4	39.688	36.322	30.162	5.0	3.3	181000	281100	18451	28654	594A/592A	2.090
	168.275	41.275	41.275	30.162	3.5	3.3	224000	347000	22834	35372	683/672	2.680
99.975	156.975	42	42	34	3.0	3.5	251000	380700	25586	38807	HM220149/HM220110	2.797
101.6	190.05	57.15	57.3	44.45	8.0	3.3	382900	562200	39032	57309	861/854	7.000
107.95	158.75	23.02	21.438	15.875	3.56	3.3	115400	196800	11764	20061	TBM37425/TBM37625	1.370
114.3	212.73	66.68	66.68	53.98	7.0	3.3	472200	691200	48135	70459	938/932	10.100
120.65	182.56	39.69	38.1	33.34	3.5	3.3	226400	441000	23078	44954	48282/48220	3.690
127	182.56	39.69	38.1	33.34	3.5	3.3	240000	430000	24465	43833	48290/48220	3.320
	228.6	53.975	49.428	38.1	3.4	3.3	414400	592500	42243	60398	HM926747/HM926710	8.830
	304.8	88.9	82.55	57.15	6.4	6.4	991300	1281400	101153	130755	HH932132/HH932110	30.100
139.7	236.538	57.15	56.64	44.45	3.5	3.3	492000	814600	50153	83038	HM231132/HM231110	10.260
146.05	236.538	57.15	56.642	44.45	3.5	3.3	488000	794000	49795	81020	HM231140/HM231110	9.340
152.4	307.975	88.9	93.662	66.675	9.7	6.8	1000000	1350000	101937	137615	HH234048/HH234010	30.000
155.575	336.55	85.725	79.375	53.975	6.4	6.0	921800	1357600	93965	138389	H936340/H936313	36.600
159.951	244.475	47.625	46.83	33.338	3.5	3.3	354000	585000	36086	59633	81630/81962	7.210
165.1	336.55	92.07	95.25	69.85	3.3	6.4	1172900	1729800	119562	176330	HH437549/HH437510	39.000

● SINGLE ROW TAPERED ROLLER BEARINGS (Inch Series)

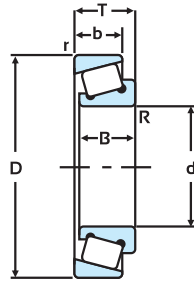

Boundary Dimension (mm)							Basic Load Rating (N)		Basic Load Rating (kgf)		Bearing Number	Mass Kg. (Approx.)
d	D	T	B	b	R	r	Dynamic Cr	Static Cor	Dynamic Cr	Static Cor		
174.625	311.15	82.55	82.55	65.088	6.4	6.4	1000000	1600000	101937	163099	H238148/H238110	27.500
	247.65	47.62	47.62	38.1	3.5	3.3	341500	693500	34811	70693	67787/67720	1.230
177.80	260.35	53.975	53.98	41.275	8.0	3.2	445900	816700	45454	83252	M236848/M236810	9.240
190.5	266.7	47.63	46.83	38.1	3.5	3.3	347100	727700	35382	74179	67885/67820	8.000
	336.55	98.43	95.25	73.02	6.4	6.4	1003200	1804600	102263	183955	HH840249/HH840210	37.300
	428.625	106.362	95.25	61.912	6.4	6.4	1166100	1521500	118869	155097	EE350750/EE351687	63.100
203.2	482.6	117.475	95.25	73.025	6.4	6.4	1400000	2000000	142857	204081	EE380080/EE380190	96.000
206.38	336.55	98.25	100.01	77.79	3.3	3.3	1119700	2049100	114139	208879	H242649/H242610	34.280
220.662	314.325	61.912	66.675	49.212	1.6	5.0	625000	1239000	63710	126300	M244249A/N1060	15.000
221.17	314.325	61.91	66.675	49.212	1.6	5.0	625000	1239000	63710	126300	M244210/N1059	14.000
228.6	320.68	50.8	49.21	33.34	6.4	3.3	402000	742800	40979	75719	88900/88126	12.660
234.95	384.175	112.712	112.712	90.488	6.4	6.4	1460000	2730000	148979	278571	H247549/H247510	50.500
247.65	406.4	115.89	117.475	93.662	6.4	3.3	3392970	6314500	345869	643680	HH249949/H249910 (N1053)	60.200
254	533.4	133.35	120.65	77.78	6.4	6.4	2024000	2874300	206320	292997	HH953749/HH953710	135.000
255.6	342.9	57.15	63.5	44.45	1.5	3.3	614100	1282400	62599	130724	M349547/M349510	13.795
257.175	358.775	71.438	76.2	53.975	1.5	3.3	818500	1663600	83435	169582	M249747/M249710	20.650
266.7	444.5	121.031	117.475	88.9	6.4	6.4	1788600	3410200	182324	347625	H852849/H852810	72.000
304.8	393.7	50.8	50.8	38.1	6.4	3.3	485000	1030000	49439	104995	L357049/L357010	13.800
	635	165.1	146.015	114.3	19.0	12.7	2910000	4960000	296938	506122	NP340527/NP360214	233.100
317.5	622.3	147.638	131.762	82.55	14.2	12.7	2561700	3722700	261131	379480	H961649/H961610	176.800
	444.5	63.5	61.912	39.688	8.0	1.5	750000	1300000	76530	132653	EE291250/EE291750	26.500
368.3	609.6	142.875	139.7	111.125	8.0	6.4	2750000	5060000	280612	516326	EE321145/EE321240	156.000
371.475	501.65	74.612	66.675	50.8	6.4	3.3	910000	1820000	92763	185525	EE231462/EE231975	36.000
381	522.288	85.725	84.138	61.912	6.4	3.3	1320000	2910000	134693	296938	LM565949/565910	50.700
385.762	514.35	82.55	82.55	63.5	6.4	3.3	1300000	3200000	132518	326198	LM665949/LM665910	50.000
425.45	685.698	142.875	142.8	104.775	12.7	6.4	3050000	5810000	311224	592857	EE328167/328269	188.000
479.425	679.45	128.588	128.588	101.6	6.4	6.4	3000000	7000000	305810	713558	M272749/M242710	141.000
571.5	812.8	155.58	155.575	120.65	6.4	6.4	10600000	4440000	1080530	452599	M278749/M278710	227.000
600	870	124	118	88	6.0	6.0	3502000	6235000	356983	635576	71/600M	234.000
630	850	108	100	78	6.0	6.0	2500000	5680000	255102	579591	10079/630	164.000
660.4	939.8	136.525	127	98.425	6.4	6.4	3490000	7800000	355759	795107	EE538260/EE538370	293.730
710	950	114	106	80	6.0	6.0	2800000	6500000	285423	662589	10079/710	211.000
762	901.7	66.675	65.088	46.038	6.4	6.4	1500000	3850000	152905	392457	LL783649/LL783610	69.300
850	1030	90	82	62	4.7	4.7	1942000	5290000	197961	539246	10078/850	141.200
900	1180	124	122	87	8.0	8.0	4140000	9740000	422018	992864	10079/900	330.000
	1280	190	170	135	7.5	7.5	6450000	14500000	657492	1478084	71/900	703.000
1320	1600	176	165	142	6.0	6.0	6350000	20550000	647299	2094801	20078/1320	719.000

● SINGLE ROW TAPERED ROLLER BEARINGS (Metric Series)

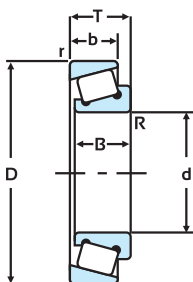

Boundary Dimension (mm)							Basic Load Rating (N)		Basic Load Rating (kgf)		Bearing Number	Mass Kg. (Apporox.)
d	D	T	B	b	R	r	Dynamic Cr	Static Cor	Dynamic Cr	Static Cor		
15	42	14.25	13	11	1.5	1.5	22700	20300	2314	2069	30302	0.096
17	40	13.25	12	11	1.0	1.0	21717	21917	2214	2234	30203	0.080
20	42	15	15	12	0.6	0.6	26100	29700	2661	3028	32004X	0.097
	47	15.25	14	12	1.5	1.5	29300	30100	2987	3068	30204	0.121
21.5	52	16.25	15	13	1.5	1.5	34700	33200	3537	3384	30304	0.160
	47	16.5	16.5	13	1.0	1.0	35100	39900	3578	4067	NI061	0.136
25	52	19.25	18	16	1.0	1.0	41900	47900	4271	4883	"32205 (Low Carbon Steel)"	0.184
	47	15	15	11.5	3.3	0.6	27800	338000	2834	34455	32005	0.120
	47	15	15	11.5	3.3	0.6	27800	33800	2834	3445	32005x1N	0.130
	47	17	17	14	0.6	0.6	32200	40200	3282	4098	33005	0.130
	52	16.25	15	13	1.5	1.5	32700	35400	3333	3609	30205	0.148
	52	19.25	18	16	1.0	1.0	41000	45000	4179	4587	32205	0.184
	52	22	22	18	1.0	1.0	47500	57500	4842	5861	33205	0.219
	62	18.25	17	15	2.0	2.0	46000	45900	4689	4679	30305	0.260
	62	18.25	17	14	1.5	2.2	42000	42300	4281	4312	30305C	0.264
	62	25.25	24	20	2.0	2.0	63000	665000	6422	67788	32305	0.381
28	67	30.5	32	24	2.5	1.0	84300	90800	8593	9256	NI114	0.513
30	55	17	17	13	1.0	1.0	38000	47500	3874	4842	"32006X (Low Carbon steel)"	0.172
	55	17	17	13	1.0	1.0	38000	47500	3874	4842	32006X	0.172
	62	17.25	16	14	1.0	1.0	443000	49000	45158	4995	30206	0.241
	62	21.25	20	17	1.0	1.0	55500	65500	5657	6677	32206	0.299
	62	25	25	19.5	1.0	1.0	63800	75400	6504	7686	33206	0.340
	72	20.75	19	16	2.0	2.0	62140	63604	6334	6484	30306	0.387
	72	20.75	19	14	1.5	2.2	58600	579000	5973	59021	30306C	0.381
	72	20.75	19	14	1.5	1.5	48500	51500	4944	5250	30306D	0.398
32	72	28.75	27	23	1.5	1.5	85000	96000	8665	9786	32306	0.560
35	58	17	17	13	1.0	1.0	37700	47000	3843	4791	320/32X	0.188
	62	18	18	14	1.5	0.5	42700	54400	4353	5545	32007X	0.224
	72	18.25	17	15	2.0	2.0	53100	58100	5413	5923	30207	0.315
	72	24.25	23	19	1.5	1.5	74207	89492	7564	9123	32207	0.447
	72	24.25	23	19	2.0	2.0	63000	77600	6422	7910	32207B	0.457
	72	28	28	22	1.5	1.5	87500	109000	8919	11111	33207	0.539
	80	22.75	21	18	2.0	2.0	60700	73900	6188	7533	30307	0.520
80	32.75	31	25	2.5	2.5	97700	109300	9959	11142	32307	0.737	
36	62	17	17	13	1.5	1.5	40000	50000	4077	5097	TS2NI126	0.197
	80	21	22.4	17.83	3.5	1.3	68000	75000	6932	7645	TMB344A/332	0.482
	68	19	19	14.5	1.0	1.0	51100	66800	5209	6809	32008X	0.273
40	80	19.75	18	16	2.0	2.0	62600	69200	6381	7054	30208	0.435
	80	24.75	23	19	1.5	1.5	79100	93600	8063	9541	32208	0.523
	80	34	34	27	2.0	2.0	103000	145000	10499	14781	NI090	0.788
	85	18.5	18.25	17	1.5	0.3	57700	64000	5882	6524	NI062	0.547
	90	25.25	23	20	2.0	1.5	84200	91400	8583	9317	30308	0.769
	90	25.25	23	17	2.0	1.5	85000	96000	8665	9786	31308	0.725
	90	35.25	33	27	2.5	2.5	117800	141900	12008	14465	32308	1.016
95	27.5	25	19	2.0	1.5	91200	101800	9297	10377	331257	0.895	

● SINGLE ROW TAPERED ROLLER BEARINGS (Metric Series)

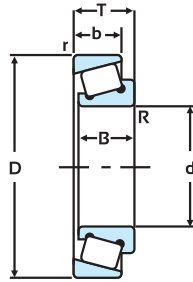

Boundary Dimension (mm)							Basic Load Rating (N)		Basic Load Rating (kgf)		Bearing Number	Mass Kg. (Approx.)
d	D	T	B	b	R	r	Dynamic Cr	Static Cor	Dynamic Cr	Static Cor		
45	100	27.25	25	18	2.0	1.5	98500	112100	10041	11427	31309X1	0.957
	100	38.25	36	30	2.5	2.5	144500	176700	14730	18012	"32309XA(32309)"	1.372
	100	38.25	36	30	2.5	2.5	144100	176100	14689	17951	"32309(32309F)"	1.373
	100	38.25	36	30	2.5	2.5	82400	100700	8400	10265	ASTB32309	1.373
	75	20	20	15.5	1.3	2.0	58500	78400	5963	7992	32009X	0.347
	85	20.75	19	16	2.0	2.0	60800	67900	6198	6922	30209	0.451
	85	24.75	23	19	1.5	1.5	84400	103700	8603	10571	32209	0.582
	100	27.25	25	22	2.0	1.5	113400	129100	11560	13160	30309	1.009
	100	27.25	25	18	2.5	2.5	99400	113500	10133	11570	31309	0.960
	100	28.35	36	30	2.5	2.5	144500	176700	14730	18012	32309	1.360
100	38.25	36	30	2.5	2.5	144500	176700	14730	18012	ASTB32309	1.360	
50	110	42.25	40	33	2.5	2.0	184100	218100	18767	22232	"AST32310(AST32310PX1)"	1.819
	80	20	20	15.5	1.3	2.0	63700	90100	6493	9185	32010X	0.373
	80	24	24	19	1.5	1.0	70400	104300	7176	10632	33010	0.433
	90	21.75	20	17	1.5	1.5	78700	95300	8022	9715	30210	0.552
	90	24.75	23	19	1.5	1.5	84700	104300	8634	10632	32210	0.648
	90	32	32	24.5	1.5	1.5	115000	158000	11723	16106	33210	0.860
	110	29.25	27	23	2.5	2.0	135000	155000	13761	15800	30310	1.280
	110	29.25	27	19	2.5	2.0	111000	126000	11315	12844	31310	1.210
110	42.25	40	33	2.5	2.0	111000	126000	11315	12844	32310	1.210	
55	140	45	40	33	2.5	2.0	202600	275900	20652	28124	4TNI243	3.427
	105	36	36	28.5	2.5	2.5	149000	192700	15189	19643	ASTBNI091XA	1.326
	120	45.5	43	35	2.5	2.0	184600	275200	18818	28053	32311C	2.489
	90	23	23	17.5	1.5	1.5	80000	118000	8155	12029	32011	0.557
	95	30	30	23	2.0	2.0	113000	159500	11519	16259	33111	0.846
	100	22.75	21	18	2.0	1.5	93000	111000	9480	11315	30211	0.740
	100	26.75	25	21	2.5	2.5	107900	133600	10999	13619	32211	0.824
	100	35	35	27	2.0	1.5	142000	192000	14475	19572	33211	1.160
	105	36	36	25.5	2.5	2.5	142200	128500	14495	13099	NI091	1.324
	120	31.5	29	25	2.5	2.0	158000	184000	16106	18756	30311	1.610
120	45.5	43	35	2.5	2.0	211000	269000	21509	27421	32311	2.370	
60	110	23.75	22	19	3.0	2.0	106900	128200	10897	13068	30212X1	0.902
	95	27	27	21	1.5	1.5	96700	151100	9857	15403	33012	0.691
	100	30	30	23	1.5	1.5	117900	172100	12018	17543	33112	0.907
	110	23.75	22	19	2.0	1.5	108000	129000	11009	13150	30212	0.902
	110	29.75	28	24	2.0	1.5	139000	179000	14169	18247	32212	1.160
	130	33.5	31	26	3.5	3.5	171200	197000	17452	20082	30312	1.930
	130	48.5	46	37	3.0	2.5	244000	315000	24873	32110	32312	2.990
	135	33.5	30.95	22	3.5	3.3	154600	182100	15759	18563	330632C	2.079
130	48.5	46	37	3.0	2.5	244000	315000	24873	32110	ASTB32312	2.990	
65	100	23	23	17.5	1.5	1.5	83000	128000	8461	13048	32013X	0.629
	145	39.75	36.5	26.5	3.5	3.3	185800	222600	18940	22691	77213L	2.955
	100	27	21	21	1.5	1.5	98000	158000	9990	16106	33013	0.736
	120	24.75	23	20	2.0	1.5	125000	151000	12742	15392	30213	1.180

● SINGLE ROW TAPERED ROLLER BEARINGS (Metric Series)

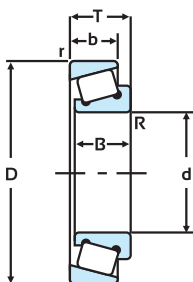

Boundary Dimension (mm)							Basic Load Rating (N)		Basic Load Rating (kgf)		Bearing Number	Mass Kg. (Apporox.)
d	D	T	B	b	R	r	Dynamic Cr	Static Cor	Dynamic Cr	Static Cor		
	120	32.75	31	27	2.0	1.5	155200	198700	15821	20255	32213	1.574
	120	41	41	32	2.0	1.5	197000	266000	20082	27115	33213	1.980
	140	36	33	28	3.0	2.5	204000	239000	20795	24363	30313	2.430
	140	36	33	23	3.0	2.5	172000	200000	17533	20387	31313	2.370
	140	51	48	39	3.0	2.5	271000	347000	27625	35372	32313	3.660
	150	38	35	25	3.0	2.5	186900	231000	19052	23547	31314	2.860
70	165	51	51	34	3.0	2.5	260000	366000	26504	37309	4TN1244	5.177
	125	26.25	24	21	4.0	1.5	137400	171800	14006	17513	30214X1	1.242
	150	64	61	42	6.0	2.5	307000	363300	31295	37034	"N1257(32314)"	4.676
	110	25	25	19	1.5	1.5	104000	160000	10601	16310	32014	0.864
	125	26.25	24	21	2.5	2.5	125500	152700	12793	15566	30214	1.240
	125	33.25	31	27	2.0	1.5	161000	210700	16412	21478	32214	1.585
	125	41	41	32	2.5	2.5	201000	282000	20489	28746	33214	2.100
	150	38	35	30	3.0	2.5	228000	269000	23242	27421	30314	2.990
	150	54	51	42	3.0	2.5	312000	406000	31804	41386	32314	4.330
	160	45	45	30	3.0	2.5	248500	328300	25331	33466	4TN1247FP5	4.070
75	115	25	25	19	3.2	2.5	107500	169800	10958	17309	32015X1F	0.888
	115	25	25	19	3.2	2.5	107300	169300	10938	17258	32015X1XA	0.888
	125	37	37	29	2.0	1.5	186000	280000	18960	28542	33115	1.780
	130	27.25	25	22	2.5	2.5	14200	181100	1448	18461	30215	1.410
	130	33.25	31	27	2.0	1.5	177252	240063	18069	24471	32215	1.740
	130	41	41	31	2.5	3.0	210100	302600	21417	30846	33215	2.225
	160	40	37	26	3.0	2.5	216000	256000	22018	26096	31315	3.380
80	160	58	55	45	3.0	2.5	346000	452000	35270	46075	32315	5.280
	170	61.5	58	48	3.0	2.5	397000	543000	40469	55352	32316	6.370
	125	29	29	22	1.5	1.5	141600	220800	14434	22508	32016X	1.284
	125	29	29	22	1.5	1.5	138000	217000	14067	22120	32016	1.270
	130	37	37	29	2.0	1.5	180300	277000	18379	28236	33116	1.839
	140	28.25	26	22	3.0	3.0	141000	169200	14373	17248	30216	1.720
	140	35.25	33	28	2.5	2.0	206049	276891	21004	28225	32216	2.180
85	180	44.5	41	28	4.0	3.0	242000	195000	24669	19878	31317	4.600
	192	64	64	45	4.0	3.0	392500	537700	40010	54811	4TN1248FP5	8.665
	150	49	49	37	2.5	2.0	280200	417700	28563	42579	33217	3.536
	150	30.5	28	24	0.4	0.3	183000	232000	18654	23649	30217X	0.172
	150	38.5	36	30	2.5	2.0	224000	300000	22834	30581	32217	2.745
	150	49	49	37	2.5	2.0	284000	420000	28950	42813	33217	3.600
	180	44.5	41	34	4.0	3.0	306000	363000	31193	37003	30317	4.970
	180	63.5	60	49	4.0	3.0	438000	587000	44648	59837	32317	7.300
	150	38.5	36	30	2.5	2.0	224000	300000	22834	30581	ASTB32217	2.745
	140	32	32	24	2.0	1.5	169000	271000	17227	27625	32018	1.790
90	160	42.5	40	34	3.0	3.0	269800	395500	27503	40316	32218	3.439
	190	46.5	43	36	4.0	3.0	354000	434000	36086	44241	30318	5.800
	190	67.5	64	53	4.0	3.0	497000	677000	50663	69011	32318	8.780
95	200	49	45	32	4.0	292000	355000	29766	36188	31319	6.950	

● SINGLE ROW TAPERED ROLLER BEARINGS (Metric Series)

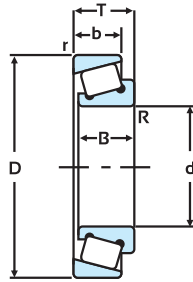

Boundary Dimension (mm)							Basic Load Rating (N)		Basic Load Rating (kgf)		Bearing Number	Mass Kg. (Approx.)
d	D	T	B	b	R	r	Dynamic Cr	Static Cor	Dynamic Cr	Static Cor		
100	145	39	39	32.5	2.5	2.5	219400	365300	22365	37238	"33019(33019F)"	2.277
	170	45.5	43	37	3.0	2.5	315000	445000	32110	45362	32219	4.240
	200	49.5	45	38	4.0	3.0	369000	478000	37615	48726	30319	6.800
	215	77.5	73	60	4.0	3.0	580000	861000	59123	87768	32320	12.700
	150	32	32	24	2.0	1.5	171900	286000	17523	29154	32020XF	1.904
	150	32	32	24	2.5	3.0	172200	286700	17554	29225	32020X	1.912
	150	39	39	32.5	2.0	1.5	224000	390000	22834	39755	33020	2.370
	180	37	34	29	3.0	2.5	258400	335100	26340	34159	30220	3.780
	225	81.5	77	63	4.0	3.0	659000	911000	67176	92864	32321	14.800

● SINGLE ROW TAPERED ROLLER BEARINGS (Metric Series)

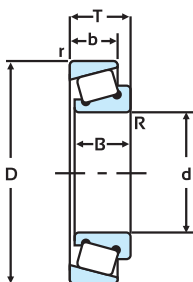

Boundary Dimension (mm)							Basic Load Rating (N)		Basic Load Rating (kgf)		Bearing Number	Mass Kg. (Approx.)
d	D	T	B	b	R	r	Dynamic Cr	Static Cor	Dynamic Cr	Static Cor		
105	225	81.5	77	63	4.0	3.0	659000	911000	67176	92864	32321	14.500
110	200	41	38	32	3.0	2.5	327000	440000	33333	44852	30222	5.210
	200	56	53	46	3.5	3.5	439000	642000	44750	65443	32222	7.700
	240	54.5	50	42	4.0	3.0	430000	580000	43833	59123	30322	11.100
	240	63	57	38	4.0	3.0	425000	590000	43323	60143	31322	12.500
	240	84.5	80	65	4.0	3.0	815600	1132000	83140	115392	32322	18.000
120	170	38	38	29	2.5	2.0	231300	380600	23602	38836	32022XF	3.000
	170	47	47	37	2.5	2.0	288000	500000	29358	50968	33022	3.800
	215	61.5	58	50	3.0	2.5	497000	751000	50663	76555	32224	9.260
	260	59.5	55	46	4.0	3.0	589000	746000	60041	76045	30324	14.200
	260	68	62	42	4.0	3.0	533000	676000	54332	68909	31324	15.200
	260	90.5	86	69	4.0	3.0	864000	1230000	88073	125382	32324	15.200
	215	43.5	40	34	3.0	2.5	345000	470000	35204	47959	30224	6.500
130	180	38	38	29	2.5	2.0	245000	420000	24975	42813	32024	3.250
	230	67.75	64	54	4.0	3.0	530000	820000	54027	83588	32226	11.500
	280	98.75	93	78	5.0	4.0	895000	1263000	91233	128746	32326	27.600
140	250	71.75	68	58	4.0	3.0	610000	980000	62181	99898	32228	14.700
	210	45	45	34	2.5	2.0	333100	589200	33989	60122	32028XF	5.280
150	225	48	48	36	3.0	2.5	365000	670000	37207	68298	32030	6.400
	270	77	73	60	4.0	3.0	700000	1130000	71428	115306	32230	18.400
	240	51	51	38	3.0	2.5	415000	730000	42304	74414	32032	7.700
160	375	86.55	79.4	50	4.7	4.7	880000	1090000	89704	111111	7832	39.400
	290	84	80	67	4.0	3.0	897000	1430000	91437	145770	32232	23.400
	260	57	57	43	3.0	2.5	519000	920000	52905	93782	32034	10.600
	260	57	57	43	3.0	2.5	519000	920000	52905	93782	32034X	10.600
170	360	127	120	100	5.0	4.0	1430000	2120000	145918	216326	32334	57.900
	230	38	38	30	2.0	2.5	286000	590000	29183	60204	32934	4.500
	250	47	45	37	3.0	2.5	376100	728400	38338	74251	JM736149/JM736110	6.700
180	320	91	86	71	5.0	4.0	950000	1650000	96840	168196	32236	29.800
	380	98	88	60	5.0	5.0	1089800	1490900	111091	151978	27336	46.000
	260	46	44	36.5	3.0	2.5	363300	715900	37034	72977	JM738249/JM738210	6.800

● SINGLE ROW TAPERED ROLLER BEARINGS (Metric Series)

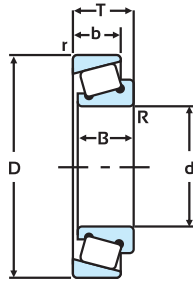

Boundary Dimension (mm)							Basic Load Rating (N)		Basic Load Rating (kgf)		Bearing Number	Mass Kg. (Approx.)
d	D	T	B	b	R	r	Dynamic Cr	Static Cor	Dynamic Cr	Static Cor		
190	290	64	64	48	3.0	2.5	655000	1210000	66769	123344	32038X	14.700
	340	97	92	75	5.0	4.0	1150000	1850000	117227	188583	32238	35.200
200	420	108	100.01	66	6.0	6.0	1293200	1863700	131825	189980	27340	63.000
220	340	76.5	66.675	62	4.0	4.0	858000	14401000	87462	1467992	2007144	22.300
240	320	51	48	41	3.0	2.5	470000	990000	47910	100917	32948	11.000
	360	76	72	62	4.0	3.0	900000	1750000	91743	178389	32048	27.300
255	560	123.05	104.8	70	6.0	6.0	1780000	2490000	181632	254081	30651	120.000
260	360	64.5	60	52	3.5	3.5	695600	1323200	70907	134883	2007952	17.700
280	420	87	82	71	5.0	4.0	1110000	2040000	113265	208163	2007156	39.300
300	460	100.7	95	82	5.0	5.0	1477500	2609700	150612	266024	2007160	55.900
	460	100	100	74	5.0	4.0	1484000	2980000	151428	304081	32060	58.000
320	480	100	100	74	5.0	4.0	1520000	2940000	155102	300000	32064	59.000
	670	210	200	170	7.5	7.5	4570000	8040000	466326	820408	32364	331.200
420	620	94	90	67	4.7	4.7	1558000	2892000	158817	294801	7184	86.800
520	740	95	86	70	2.5	6.0	1850000	3375000	188583	344037	77/520M	110.000

● DOUBLE ROW TAPERED ROLLER BEARINGS

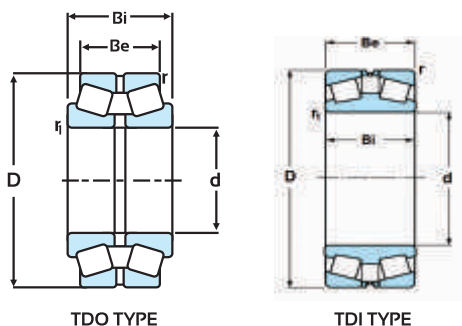

Boundary Dimension (mm)						Basic Load Rating (N)		Basic Load Rating (kgf)		Bearing Number	Type	Mass Kg. (Apporox.)
d	D	Bi	Be	R	r	Dynamic Cr	Static Cor	Dynamic Cr	Static Cor			
99.98	196.85	103.38	74.42	3.6	1.5	548200	780700	55882	79582	HM821547/HM821511D	TDO	14.650
101.6	200.025	115.888	80.216	3.6	2.4	591000	936000	60245	95413	98400/98789D	TDO	15.000
	146.05	49.212	39.688	1.5	0.8	182000	331000	18571	33775	L521945/L521910D	TDI	2.430
104.78	180.98	104.78	85.73	3.6	1.5	496300	876500	50591	89348	782/774D	TDO	11.240
	180.98	104.78	85.73	3.5	1.5	496300	876500	50591	89348	NA782/774D	TNA	11.240
105	190	117.25	96	3.0	1.1	610000	1100000	62181	112131	97521	TDO	14.000
115.087	190.5	106.362	80.962	1.6	3.6	565000	950000	57594	96840	71453/717551D	TDO	11.000
120	260	136	124	1.5	3.0	1050000	1426000	107142	145510	31324XDF	TDI	30.200
127	196.85	101.6	85.725	3.5	0.8	550000	1150000	56122	11734	67388/67322D	TDO	11.000
127.792	228.6	115.888	84.138	3.5	2.3	570000	1200000	58104	122324	HM926749/HM926710D	TDI	19.000
130	230	150	120	4.0	2.0	945000	1645000	96330	167686	97526	TDO	25.300
	280	132	144	4.0	1.3	1050000	1590000	107034	162080	31326X/DF	TDO	27.600
133.35	196.85	92.075	92.075	3.3	1.5	550000	1200000	56065	122324	67390D/67322	TDI	9.500
140	300	140	154	1.5	4.0	1200000	1830000	122324	186544	31328X/DF	TDI	51.500
142.88	200.03	93.66	73.03	3.5	0.8	372700	986200	37992	100530	NA48686/48620D	TNA	8.430
	250	137.25	112	2.5	1.0	785000	1560000	80020	159021	2097730	TDI	25.800
150	270	172	138	4.0	1.5	1350900	2388000	137706	243425	97530	TDO	39.100
	320	164	150	1.5	4.0	1360000	2250000	138775	229591	31330XDF	TDI	58.500
152.4	254	142.876	111.125	7.9	3.5	996000	1930000	101529	196738	NA99600/99102CD	TDO	27.300
159.95	244.48	107.95	79.37	3.5	1.5	589100	1069000	60051	108970	81630/81963D	TDO	18.180
160	270	150	120	2.5	1.0	1070000	1890000	109072	192661	2097732	TDI	27.200
165.1	288.925	142.875	111.125	1.5	7.0	1160000	2140000	118247	218145	HM237535/HM237510D	TDO	36.500
170	260	114	114	1.0	2.5	1050000	1915000	107142	195408	32034XDF	TDI	21.000
177.8	279.4	133.353	96.838	3.3	1.6	863000	1872000	87971	190826	82680X/82620D	TDO	29.000
	288.925	123.825	123.825	1.5	3.3	1090000	1980000	111111	201835	HM237546D/HM237510	TDI	31.000
	288.925	142.875	111.125	1.5	5.6	940000	1900000	95821	193680	NA94700/94111D	TDO	33.600
180	280	128	128	1.0	2.5	1100000	2320000	112130	236493	32036X/DF	TDI	29.500
	300	163.25	134	3.0	1.0	1220000	2360000	124489	240816	2097736	TDO	43.500
190.5	280	133.25	108	3.0	1.0	940000	1810000	95918	184693	2097136	TDO	29.000
	266.7	103.19	84.14	3.5	0.8	6099270	1500000	621740	152905	67885/67820D	TDO	17.700
200	368.3	158.75	152.4	3.3	3.3	1690000	3200000	172448	326530	EE420750D/EE421450	TDI	77.900
	310	151	123	3.0	1.0	995000	2080000	101427	212029	2097140	TDI	38.300
203.2	340	183	150	4.0	1.5	1650000	3400000	168367	346938	2097740	TDO	65.500
	317.5	146.05	111.125	1.5	4.3	1060000	2310000	108053	235474	93800/93127D	TDO	39.000
206.375	336.55	184.15	180.975	3.3	1.5	2216200	4071800	225912	415066	H242649D/H242610	TDI	63.750
	282.575	190.5	190.5	3.3	3.3	1066400	3151100	108705	321213	67985/67920D	TDO	18.200
220	340	163	130	4.0	1.5	1530000	2980000	155963	303772	2097144	TDO	49.300
220.662	314.325	131.762	106.362	6.4	1.5	1070000	2450000	109183	250000	M244249/M244210D	TDO	30.600
228.46	431.8	184.15	184.15	6.4	6.4	1479400	2511900	150805	256055	EE113091/EE113170	TDI	108.400

● DOUBLE ROW TAPERED ROLLER BEARINGS

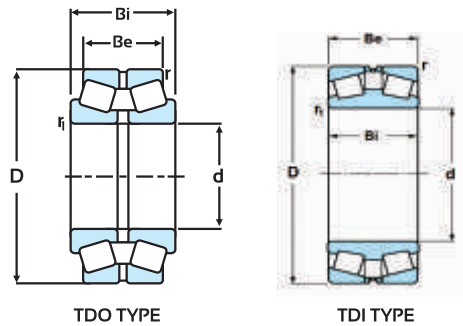

Boundary Dimension (mm)						Basic Load Rating (N)		Basic Load Rating (kgf)		Bearing Number	Type	Mass Kg. (Approx.)
d	D	Bi	Be	R	r	Dynamic Cr	Static Cor	Dynamic Cr	Static Cor			
228.6	355.6	152.4	111.125	1.5	6.8	1230000	2510000	125382	255861	EE130902/EE13140ID	TDO	50.200
234.95	384.175	238.125	193.675	6.4	1.5	2500000	5450000	255102	556122	H247549/H247510D	TDO	105.000
240	327.025	114.3	82.55	1.6	6.4	670000	1020000	68298	103976	8574/8520	TDO	27.000
	320	109	90	3.0	1.1	690000	1610000	70336	164118	2097948	TDI	22.000
	360	165	130	4.0	1.0	1360000	2940000	138634	299694	2097148	TDI	46.000
	400	209	168	5.0	2.0	1870000	4050000	190622	412844	2097748	TDI	98.500
241.3	327.025	185.224	217.466	3.3	2.0	765000	1740000	77982	177370	8578/8520DF	TDI	54.000
247.65	406.4	234.95	231.776	1.5	6.4	3392970	6314500	345869	643680	HH249949D/HH249910	TDO	98.000
	406.4	247.65	206.2	1.5	6.4	2680000	5800000	273191	591233	NP985601/NP490062	TDO	122.000
260	360	133	109	3.5	1.2	1200000	2652000	122324	270336	2097952	TDO	36.800
	400	185	146	1.3	3.7	1760000	3790000	179409	386341	2097152	TDO	74.300
	420	170	170	5.0	5.0	2079600	4047200	211988	412559	47752	TDI	88.500
	440	225	180	4.0	1.3	2440000	4750000	248726	484200	2097752	TDI	124.000
279.4	457.2	244.475	244.475	1.5	6.4	3489700	7685000	355729	783384	HH255149D/HH255110	TDI	163.600
280	420	188	154	5.0	2.0	1910000	4080000	194897	416326	2097156	TDO	85.000
	420	160	128	4.0	1.0	1510000	3630000	153925	370031	2097960	TDO	62.900
300	500	204	152	1.8	4.7	2510000	4910000	255861	500510	1097760	TDO	148.000
	460	180	180	5.0	2.5	1940000	4000000	197757	407747	NI322	TDI	110.000
304.8	438.048	153.984	152.4	4.8	1.5	1450000	3400000	147808	346585	EE129120X/EE129172D	TDO	71.000
305	510	200	200	5.0	5.0	1650000	5000000	168196	611621	NI326	TDI	163.000
305.08	500	200	200	5.0	4.0	2228000	4692000	227115	478288	NI021	TDI	154.600
	500	200	200	5.0	5.0	2374800	5094600	242080	519327	NI021M	TDI	154.600
320	620	250	282.75	6.0	2.5	3759100	6431400	383191	655596	NI051	TDI	400.000
333.375	469.9	109.5	152.4	6.4	1.5	2320000	5500000	236734	561224	HM261049/HM261010D	TDO	97.000
340	460	159	128	4.0	1.0	1700000	4190000	173293	427115	2097968	TDO	71.000
	580	241	170	1.8	5.0	3200000	6080000	326530	620408	1097768	TDO	235.000
346.07	488.95	200.02	158.75	6.4	1.5	3021300	6311800	307982	643405	HM262749/HM262710D	TDO	117.600
360	480	159	128	4.0	1.0	1760000	4380000	179591	446938	2097972	TDO	73.700
	680	300	330	8.0	3.0	6887000	11574000	702039	1179817	332298	TDI	54.000
379	681.5	307	307	6.0	6.0	6450000	14300000	657492	1457696	NI208	TDI	522.550
380	620	240	170	6.0	2.5	3100000	6850000	206096	353660	1097776	TDO	250.000
384.18	546.1	222.25	177.8	6.4	1.5	3217500	8250500	327982	841030	HM266449/HM266410D	TDO	165.000
390	590	200	200	2.5	7.0	2677000	6821000	272885	695311	JM966747DW/JM966718W	TDI	190.157
	548	180	180	5.0	2.0	2060000	5300000	209990	540265	NI321	TDI	140.000
400	600	206	150	6.0	2.5	2770200	6059500	282385	617686	97180	TDO	180.000
406.4	539.75	142.88	101.6	6.4	1.5	1355400	3229400	138165	329195	EE234160/EE234213D	TDO	88.800
420	700	275	200	2.5	6.0	4537900	9253900	462579	943313	1097784	TDO	406.000
440	650	211	152	6.0	2.5	2860000	6900000	291836	704081	97188	TDO	212.000
460	680	230	175	8.0	3.5	3435400	7588300	350194	773527	97192	TDO	253.000

● DOUBLE ROW TAPERED ROLLER BEARINGS

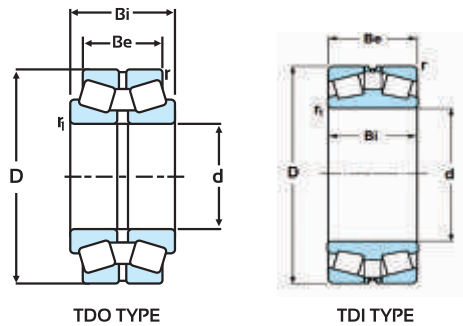

Boundary Dimension (mm)						Basic Load Rating (N)		Basic Load Rating (kgf)		Bearing Number	Type	Mass Kg. (Apporox.)
d	D	Bi	Be	R	r	Dynamic Cr	Static Cor	Dynamic Cr	Static Cor			
480	650	179	130	6.0	2.5	2250900	5510000	229450	561672	1097996	TDO	151.000
488.95	660.4	206.38	158.75	6.4	1.5	3500000	9100000	356779	927625	EE640192/EE640261D	TDO	200.000
489.026	634.873	320.675	320.675	3.3	3.3	4348900	14154800	443313	1442895	EE243193D/EE243250	TDI	131.500
530	710	190	136	5.0	1.5	2780000	6720000	283673	685714	10979/530	TDO	182.000
558.8	736.6	187.328	138.112	3.3	6.4	2500000	6750000	254842	688073	EE843220/EE843291D	TDO	189.000
560	750	213	156	6.0	2.5	3162700	8059800	322396	821590	10979/560	TDO	235.000
	820	242	242	8.0	11.0	4390000	11557000	520184	1121305	8471/560	TDI	427.000
600	820	258.5	185	2.5	6.0	4716000	1065000	480734	108563	971/560	TDO	400.000
	800	210	160	6.0	2.5	3462000	9846200	352905	1003690	10979/600	TDO	242.000
609.6	870	268.5	268.5	6.0	2.5	6006000	12472000	612232	1271356	971/600M	TDO	497.000
	793.75	206.38	158.75	6.4	1.5	3462000	9846200	352905	1003690	EE649240/EE649313D	TDO	262.000
710	950	240	175	6.0	2.5	4110000	11000000	418960	1121305	10979/710	TDO	440.000
762	965.2	187.33	133.35	6.4	1.5	3392100	10084800	345780	1028012	EE752300/EE752381D	TDO	324.000
800	1150	348.5	348.5	7.5	3.0	9300000	20429000	948012	2082467	971/800M	TDO	205.000
850	1120	268	188	6.0	2.5	6860000	18700000	700000	1908163	10979/850	TDO	647.000
950	1250	300	220	10.0	4.0	7379500	20474100	752243	2087064	10979/950	TDO	930.000

● FOUR ROW TAPERED ROLLER BEARINGS

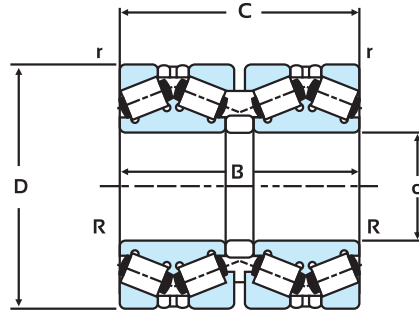

Boundary Dimension (mm)						Basic Load Rating (N)		Basic Load Rating (kgf)		Bearing Number	Type	Mass Kg. (Approx.)
d	D	C	B	R	r	Dynamic Cr	Static Cor	Dynamic Cr	Static Cor			
127	182.526	158.75	158.75	3.3	3.3	660000	1730000	67278	176351	48290DGW/20/20D	TDI	13.800
136.525	190.5	161.925	161.925	1.6	3.3	807000	1890000	82346	192857	48393DW/20/20D	TQI	14.000
139.7	215.9	187.324	212.724	12.7	1.5	935000	2160000	95311	220183	74555/74555D/74849XD	TQI	26.400
177.8	247.65	192.088	192.088	1.5	3.2	1372000	2768300	139857	282192	67790DW/20/21D	TQO	28.130
180.843	284.162	101.6	239.715	3.3	1.5	1473200	3662700	150173	373364	M240631T/44TD/47T/44D	TQIT	60.000
187.325	269.875	211.138	211.138	3.3	1.5	1240000	3400000	126402	346585	M238849D/10/10D	TQO	41.800
200	340	305	305	4.0	4.0	2522162	5760800	257101	587238	2077144	TQO	104.000
206.375	282.575	190.5	190.5	3.3	3.3	1066400	3151100	108705	321213	67985DW/20/21D	TDI	36.500
215.9	288.925	177.8	177.8	0.8	3.3	1400000	3600000	142712	366972	LM742749DW/14/14D	TDI	32.000
220.663	314.325	239.713	239.713	1.5	3.3	2100000	5100000	214067	519878	M244249D/10/10D	TDI	60.400
234.95	327.025	196.85	196.85	3.3	3.3	1370000	3700000	139653	377166	8576DW/20/20D	TDI	49.200
244.475	327.025	193.675	193.675	1.5	3.3	1569000	4309000	159939	439246	LM247748DGW/10/10D	TDI	43.590
246.327	381	301.625	301.625	6.4	1.5	2470000	6850000	251784	698267	M252330T/45TD/49T/10DM	TQIT	111.000
254	358.775	269.875	269.875	3.3	3.3	3200000	7100000	326198	723751	M249748D/10/10D	TDI	86.000
260	440	128	330	5.0	1.5	3300000	7772000	336391	792253	477752	TQIT	196.000
266.7	355.6	228.6	230.19	1.6	3.2	1858400	5405000	189439	550968	LM451349DW/10/10D	TQO	65.500
269.875	381	282.575	282.575	4.0	4.0	2571700	7077200	262151	721427	M252349D/10/10D	TDI	96.590
279.4	393.7	269.875	269.875	1.5	6.4	2340000	6560000	238775	669387	EE135111DW/55/56D	TQO	103.000
279.578	380.9	244.48	244.48	1.5	3.2	1973100	6020300	201131	613690	LM654644DW/10/10D	TQO	81.670
280	460	324	324	3.0	6.0	3350000	8350000	341488	851172	1077756	TQO	220.000
280.27	379.89	244.48	244.48	1.5	3.2	2631000	5900000	268196	601427	NI028	TQO	79.200
285.75	380.9	244.48	244.48	1.5	3.2	1973100	6020300	201132	613690	LM654648DW/10/10D	TQO	76.420
288.925	406.4	298.45	298.45	3.3	3.3	3132700	8953800	319337	912722	M255449D/10/10D	TQO	125.000
300	460	390	390	5.0	5.0	4300000	10550000	438328	1075433	2077160	TDI	238.000
317.5	422.275	269.875	269.875	1.5	3.3	3360000	8150000	342857	831632	LM258648DGW/10/10D	TQO	105.000
343.05	457.1	254	254	1.6	3.2	2415600	6751700	246239	688247	LM761649DW/10/10D	TQO	110.000
347.662	469.9	292.1	292.1	3.3	3.3	3200000	9100000	326198	927625	M262449D/10/10D	TQO	148.000
355.6	482.6	269.875	265.112	1.5	3.3	2790000	7650000	284404	779817	LM763449DW/10/10D	TQO	134.000
	488.95	317.5	317.5	1.5	3.3	3500000	10500000	356779	1070336	M263349DW/10/10D	TQO	177.000
368.3	523.875	382.588	382.588	3.3	6.4	4800000	14000000	489297	1427115	HM265049DW/10/10D	TDI	267.000
380	620	418.5	420	6.0	6.0	6320000	15000000	644241	1529052	1077776	TDI	480.000
384.175	546.1	400.05	400.05	3.3	6.4	7100000	15800000	723751	1610601	HM266449DW/10/10D	TDI	305.000
400	530	370	370	3.0	5.0	4350000	13650000	443877	1392857	NI325	TDI	213.000
406.4	546.1	288.93	288.93	1.5	6.4	3200000	10200000	326198	1039755	LM767749DW/10/10D	TQO	185.000
431.8	571.5	336.55	336.55	1.5	6.4	4050000	12900000	412844	1314985	LM769349DW/10/10D	TQO	230.000
450	595	368	368	3.0	6.0	5078300	16506000	517666	1682569	M270449DGW/10/10D	TDI	284.000
460	730	438.5	438.5	5.0	10.0	8438000	18000000	861020	1836734	777792	TQO	728.000
	625	421	421	9.5	8.0	8200000	19850000	835882	2023445	M271149D/10/10D	TQO	377.150
475	620	380	380	3.0	5.0	5858300	18013500	597176	1836239	JM171649DGW/10/10D	TQO	293.800
480	700	77	420	6.0	2.5	8543000	18500000	870846	1885831	577796	TQO	537.000
482.6	647.7	417.512	417.512	3.3	6.4	6050000	19000000	616718	1936799	M272647DW/10/10D	TDI	398.000
488.95	660.4	361.95	365.125	8.0	6.4	5350000	16100000	545362	1641182	EE640193DW/60/61D	TDI	358.800
489.026	634.873	320.675	320.68	3.3	3.3	4348900	14154800	443313	1442895	EE243193DW/250/251D	TQO	270.000
500	720	420	420	8.0	8.0	6761000	18275000	689195	1862895	10771500	TQO	560.000
	830	570	570	10.0	10.0	1099330	26624700	112062	2714037	10777500	TQO	1250.000
558.8	736.6	322.26	322.26	3.3	6.4	6225000	16088100	634557	1639969	EE843221D/90/91D	TQO	375.000
571.5	812.8	593.725	593.725	3.3	6.4	11800000	33800000	1202854	3445464	M278749DGW/10/10D	TDI	1012.000
585.788	771.525	479.425	479.425	6.4	3.3	7350000	25700000	749235	2619776	LM278849D/10/10D	TQO	750.000
600	800	365	365	5.0	5.0	5944700	19692400	605984	2007380	7797600	TQO	531.000
630	920	515	515	10.0	10.0	9900300	27582300	009205	2811651	7717630	TQO	1160.000
649.924	914.898	674	672	3.6	6.0	13900000	44600000	1418367	4551020	M281349D/10/10D	TQO	144.000
660.4	812.8	365.13	365.13	3.2	6.4	7716000	20973000	786544	2137921	L281149D/10/10D	TQO	420.000
670	1090	710	710	1.0	10.0	18936000	49719000	1930275	5068196	107777670	TQO	266.000
708.025	930.275	565.15	565.15	3.3	6.4	11000000	37500000	1121305	3822630	LM282549DW/10/10D	TDI	1070.000
750	1130	690	690	10.0	10.0	17120500	50489200	1745209	5146707	7777750	TQO	2550.000
939.8	1333.5	952.5	952.5	4.83	12.7	29726000	102310000	3030173	10429154	LM287849DW/10/10D	TQO	4390.000

*Type:

- TQO = One double cup, two single cups, with two cup spacers, two double cones with one cone spacer
- TQIT = Two double cups with one cup spacer, one tapered bore double cone & two tapered bore single cone without cone spacer
- TQI = Two double cups with one cup spacer, one double cone & two single cone

● THRUST BEARINGS

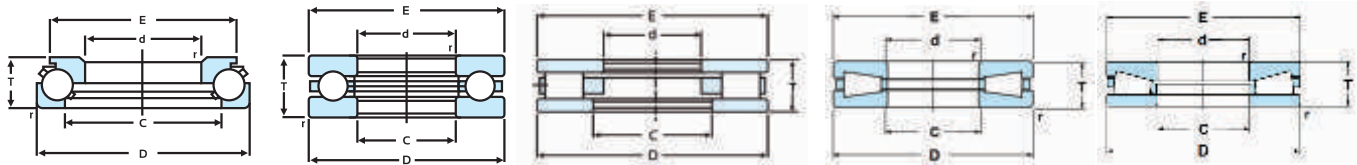

TL SERIES

BALL THRUST

CRB THRUST

TRB THRUST- TTHD TYPE

TRB THRUST- TTVF TYPE

Boundary Dimension (mm)						Basic Load Rating (N)		Basic Load Rating (kgf)		Bearing Number	Type	Mass Kg. (Apporox.)
d	C	D	E	T	r	Dynamic Cr	Static Cor	Dynamic Cr	Static Cor			
76.2	82.55	119.84	116.66	25.4	5X45°	156300	466600	15933	47564	T624	CRB	1.070
88.9	90.475	138.887	129.362	33.325	-	166500	528000	16972	53823	AT626	CRB	1.870
100	123	220	100	143	2.1	325000	931000	33163	95000	48324	BALL	23.000
110	165	230	188	73	4.0	237400	520800	24200	53089	TL110	BALL	11.340
	113	187	190	63	2.0	279600	705300	28530	71969	51322	BALL	7.170
120	179	250	206	78	4.0	268900	615900	27411	62783	TL120	BALL	14.580
127	127	266.7	266.7	58.738	4.8	1350000	4480000	137615	456677	T511-TTHD	TRB	19.000
140	203	280	234	85	5.0	297300	737800	30306	75209	TL140	BALL	18.860
152.4	154	254	252.4	50.8	4.0	715810	3214123	72967	327637	9923	CRB	10.980
	153	317.5	317	69.85	6.4	1350000	7800000	137615	795107	T611-TTHD	TRB	32.000
160	233	320	266	95	5.0	366600	989700	37370	100887	TL160	BALL	28.120
203.2	203.2	419.1	419.1	92.075	9.7	2490000	10600000	253823	1080530	T811-TTHD	TRB	69.300
228.6	228.6	482.6	482.6	104.775	11.2	3500000	14700000	356779	1498471	T911-TTHD	TRB	103.000
260	265	480	475	132	6.0	3300000	12800000	336734	1306122	9019452	TRB	115.000
	260.5	420	419.5	95	5.0	1475000	5850000	150357	596330	9809352	CRB	58.000
279.4	282.575	603.25	601.726	136.525	11.2	7701000	7910000	785015	3333639	T1100-TTHD	TRB	198.000
	282.575	603.25	601.726	136.525	11.2	7910000	32703000	806320	3337040	N1146	TRB	198.000
280	284	380	375	80	2.1	493000	1980000	50306	202040	51256M	BALL	25.300
304.8	307.181	609.6	607.219	114.3	9.5	3906711	23041514	398238	2348778	N1011	CRB	157.000
340	341	540	540	160	6.0	1121100	4439800	114281	452579	8368	BALL	148.000
630	631	850	850	175	8.0	1326600	8040500	135229	819623	82/630	BALL	252.000
670	672	800	800	105	5.0	858200	5489600	87482	559592	81/670	BALL	105.000
710	711	950	950	185	8.0	1214600	8018200	123812	817350	N1013	BALL	407.000

● SPHERICAL ROLLER BEARINGS

Spherical roller bearings consist of an outer ring having a continuous spherical raceway within which operates two rows of barrel-shaped rollers which are in turn guided by an inner ring with two raceways separated by a center rib. (Refer to **Diagram 1**) This bearing has self-aligning properties, and therefore is suited for use where misalignment between the inner and outer rings occurs from housing installation error or shaft flexure. Spherical roller bearings have a large capacity for radial loads, axial loads in either direction, and complex loads. They are also suited for applications where vibration and shock loads are encountered.

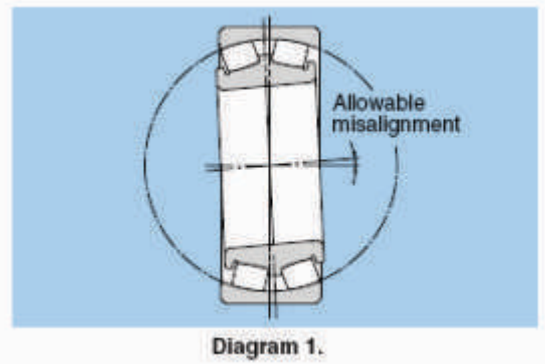

Type of configuration

- CA - Bearing with symmetrical rollers and retaining ribs. The cage is a one-piece, double pronged machined cage of brass
- CC - Bearing with symmetrical rollers, flangeless inner ring, a non-integral guide ring between the two rows of rollers centred on the inner ring and one pressed steel window-type cage for each roller row
- MB - Machined brass cage

In addition to bearings with cylindrical bore, those with tapered bore are also available. Bearings with tapered bore are specified by attaching the suffix "K" to the end of the bearing's basic number. The standard taper ratio is 1:12 for

bearings with a "K" suffix, but for bearings in series 240 and 241 the suffix "K30" indicates the taper ratio for a bearing is 1:30. Most tapered bore bearings incorporate the use of adapters and withdrawal sleeves for shaft mounting.

K - Tapered bearing bore, taper 1:12

K30 - Tapered bearing bore, taper 1:30

Oil inlets and oil groove dimensions

Spherical roller bearings with an outer diameter of 320mm or more are provided with an oil inlet and oil groove on the outer ring for the purpose of supplying lubricant to the bearing's moving parts. When necessary, oil inlets and oil grooves can also be provided on bearings with outer diameters less than 320 mm.

W33 - Bearing with annular groove and three lubrication holes in the outer ring

W33X - Bearing with annular groove and six lubrication holes in the outer ring

Adapters and withdrawal sleeves

Adapters are used for installation of bearings with tapered bore on cylindrical shafts. Withdrawal sleeves are also used to install and disassemble bearings with tapered bore onto and off of cylindrical shafts. In disassembling the bearing

from the shaft, the nut is pressed down against the edge of the inner ring utilizing the bolt provided on the withdrawal sleeve, and then the sleeve is drawn away from the bearing's inner diameter surface. As shown in Diagram 2 construction is designed to reduce friction by injecting high pressure oil between the surfaces of the adapter sleeve and bearing inner bore by means of a pressure fitting.

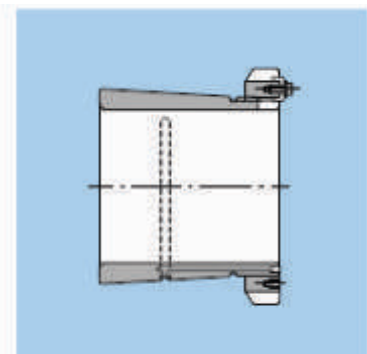

*Adapter as well as Withdrawal Sleeves are also available

● SPHERICAL ROLLER BEARINGS

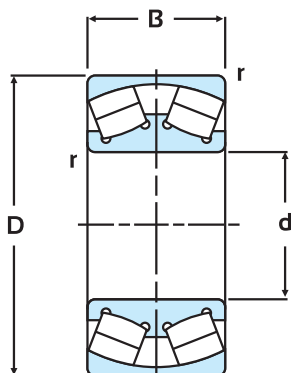

Cylindrical bore

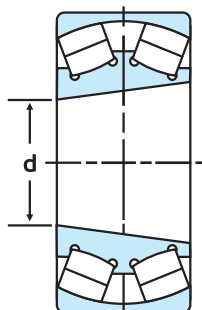

Tapered bore (K)
(1:12)

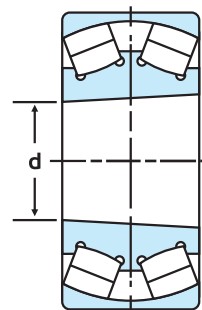

Tapered bore (K30)
(1:30)

Boundary Dimension (mm)				CONFIGURATION							Basic Load Rating (N)		Basic Load Rating (kgf)		Bearing Number	Mass Kg. (Approx.)
d	D	B	r	CA	CC	MB	K	K30	W33	W33X	Dynamic Cr	Static Cor	Dynamic Cr	Static Cor		
25	52	18	1.0		✓			✓			42000	44000	4281	4485	22205	0.180
30	62	20	1.0		✓			✓			52000	55000	5301	5607	22206	28.000
35	72	23	1.1		✓			✓			70000	79000	7136	8053	22207	0.440
40	80	23	1.1		✓	✓	✓	✓			81000	90000	8257	9174	22208	0.470
	90	33	1.5			✓	✓	✓			123000	142000	12538	14475	22308	1.030
45	85	23	1.1		✓	✓	✓	✓			84000	98000	8563	9990	22209	0.590
	100	36	1.5			✓	✓	✓			146000	175000	14883	17839	22309	1.400
50	90	23	1.1		✓	✓	✓	✓			87000	104000	8869	10601	22210	0.620
	110	40	2.0			✓	✓	✓			193000	227000	19674	23140	22310	1.880
55	100	25	1.5		✓	✓	✓	✓			102000	119000	10398	12130	22211	0.830
	120	43	2.0			✓	✓	✓			214000	258000	21814	26300	22311	2.330
	130	31	2.1	✓		✓	✓	✓			150000	180000	15291	18349	21312	2.100
60	110	28	1.5			✓	✓	✓			132000	156000	13456	15902	22212	1.230
	130	46	2.1			✓	✓	✓			240000	310000	24465	31600	22312	2.900
65	120	31	1.5			✓	✓	✓			147000	181000	14985	18451	22213	1.540
	140	48	2.1			✓	✓	✓			295000	353000	30071	35984	22313	3.610
70	125	31	1.5			✓	✓	✓			170000	218000	17329	22222	22214	1.640
	150	51	2.1			✓	✓	✓			342000	426000	34862	43425	22314	4.410
75	160	37	2.1	✓		✓	✓	✓			280000	360000	28542	36697	21315	3.700
	130	31	1.5		✓	✓	✓	✓			163000	215000	16616	21916	22215	1.690
80	160	55	2.1			✓	✓	✓			73000	451000	7441	45973	22315	5.890
	140	33	2.0			✓	✓	✓			179000	240000	18247	24465	22216	2.260
85	170	58	2.1			✓	✓	✓			436000	533000	44444	54332	22316	6.340
	150	36	2.0		✓	✓	✓	✓			213000	282000	21713	28746	22217	2.870
90	180	60	3.0		✓	✓	✓	✓			431000	539000	43935	54944	22317	7.250
	160	40	2.0			✓	✓	✓			297000	398000	30275	40571	22218	3.500
95	190	64	3.0			✓	✓	✓			489000	641000	49847	65341	22318	8.350
	160	52.4	2.0			✓	✓	✓			340000	485000	34659	49439	23218	4.570
100	170	43	2.1			✓	✓	✓			314000	410000	32008	41794	22219	4.570
	200	67	3.0	✓	✓	✓	✓	✓			536000	709000	54638	72273	22319	10.090
110	180	46	2.1			✓	✓	✓			316000	435000	32212	44343	22220	5.030
	215	73	3.0			✓	✓	✓			626000	840000	63812	85627	22320	12.950
	165	52	2.0			✓	✓	✓			340000	525000	34659	53517	23120	4.340
	180	60.3	2.1			✓	✓	✓			428000	637000	43629	64934	23220	6.700
120	200	53	2.1			✓	✓	✓			417000	592000	42508	60347	22222	7.300
	240	80	3.0		✓	✓	✓	✓			750000	963000	76453	98165	22322	18.120
	170	45	2.0			✓	✓	✓			282000	455000	28746	46381	23022	3.630
	180	56	2.0			✓	✓	✓			450000	700000	45872	71356	23122	5.400
120	200	69.8	2.1			✓	✓	✓			430000	650000	43833	66259	23222	9.900
	215	58	2.1			✓	✓	✓			507000	697000	51682	71050	22224	9.140
	260	86	3.0		✓	✓	✓	✓			884000	1154000	90112	117635	22324	22.670
	180	46	2.0			✓	✓	✓			296000	495000	30173	50459	23024	4.200

● SPHERICAL ROLLER BEARINGS

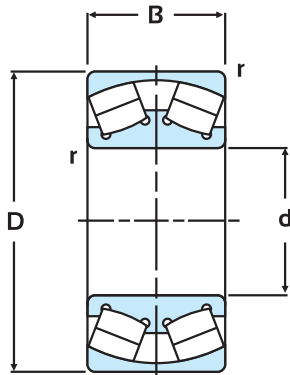

Cylindrical bore

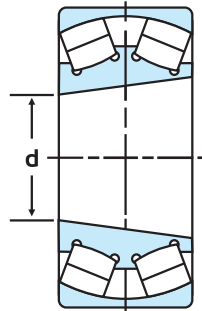

Tapered bore (K)
(1:12)

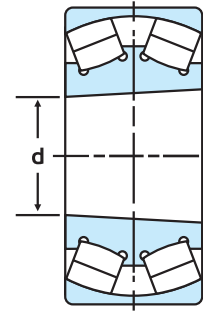

Tapered bore (K30)
(1:30)

Boundary Dimension (mm)				CONFIGURATION								Basic Load Rating (N)		Basic Load Rating (kgf)		Bearing Number	Mass Kg. (Approx.)
d	D	B	r	CA	CC	MB	K	K30	W33	W33X	Dynamic Cr	Static Cor	Dynamic Cr	Static Cor			
130	200	62	2.0			✓	✓	✓			460000	705000	46891	71865	23124	8.000	
	215	76	2.1			✓	✓	✓			595000	950000	60652	96840	23224	12.300	
	180	60	2.0	✓		✓		✓			390000	700000	39755	71356	24024	5.270	
	230	64	3.0			✓	✓	✓			636000	898000	64832	91539	22226	11.100	
	280	93	4.0			✓	✓	✓			1020000	1377000	103976	140367	22326	27.500	
	200	52	2.0			✓	✓	✓			375000	620000	38226	63201	23026	6.000	
	210	64	2.0			✓	✓	✓			590000	940000	60143	95821	23126	8.470	
	230	80	3.0			✓	✓	✓			795000	1172000	81040	119470	23226	14.300	
140	250	68	3.0			✓	✓	✓			685000	975000	69827	99388	22228	14.500	
	300	102	4.0			✓	✓	✓			1154000	1620000	117635	165138	22328	35.500	
	210	53	2.0	✓		✓	✓	✓			415000	695000	42304	70846	23028	6.660	
	250	88	3.0			✓	✓	✓			826000	1320000	84200	134557	23228	19.300	
	210	69	2.0			✓		✓			510000	945000	51988	96330	24028	8.700	
	280	93	4.0			✓	✓	✓			830000	1250000	84608	127421	23727	26.000	
150	270	73	3.0			✓	✓	✓			800000	1200000	81549	122324	22230	18.600	
	320	108	4.0		✓	✓	✓	✓			1120000	1690000	114169	172273	22330	43.900	
	225	56	2.1			✓	✓	✓			450000	795000	45872	81040	23030	8.100	
	225	80	2.1			✓	✓	✓			730000	1190000	74414	121305	23130	16.300	
	270	96	3.0			✓	✓	✓			950000	1500000	96840	152905	23230	24.100	
	225	75	2.1			✓	✓	✓			607000	1116000	61876	113761	24030	10.530	
160	290	80	3.0			✓	✓	✓			920000	1290000	93782	131498	22232	22.960	
	240	60	2.1			✓	✓	✓			500000	875000	50968	89195	23032	9.600	
	270	86	2.1			✓	✓	✓			839000	1350000	85525	137615	23132	20.200	
	290	104	3.0			✓	✓	✓			1100000	1760000	112130	179409	23232	30.900	
	240	80	2.1			✓	✓	✓			711000	1329000	72477	135474	24032	12.820	
	310	86	4.0			✓	✓	✓			999000	1518000	101835	154740	22234	28.500	
170	360	120	4.0	✓	✓	✓	✓	✓			154000	2240000	15698	228338	22334	58.500	
	260	67	2.1			✓	✓	✓			640000	1080000	65240	110092	23034	13.200	
	280	88	2.1			✓	✓	✓			840000	1530000	85627	155963	23134	21.900	
	310	110	4.0			✓	✓	✓			1180000	1960000	120285	199796	23234	37.300	
	260	90	2.1			✓		✓			700000	1450000	71356	147808	24034	17.900	
	280	109	2.1			✓	✓	✓			1020000	1800000	103976	183486	24134	26.900	
180	320	86	4.0			✓	✓	✓			1080000	1630000	110092	166157	22236	29.300	
	380	126	4.0			✓	✓	✓			1730000	2560000	176351	260958	22336	69.000	
	280	74	2.1			✓	✓	✓			740000	1290000	75433	131498	23036	17.500	
	310	120	2.1			✓	✓	✓			910000	1614000	92762	164526	23040	32.300	
	300	96	3.0			✓	✓	✓			1030000	1730000	104995	176351	23136	26.000	
	320	112	4.0			✓	✓	✓			1230000	2130000	125382	217125	23236	39.000	
	280	100	2.1	✓				✓			930000	1700000	94801	173293	24036	23.500	
	300	118	3.0	✓				✓			1250000	2210000	127421	225280	24136	33.000	
190	340	92	4.0			✓	✓	✓			1150000	1820000	117227	185525	22238	35.600	
	290	75	2.1			✓	✓	✓			760000	1350000	77472	137615	23038	17.500	

● SPHERICAL ROLLER BEARINGS

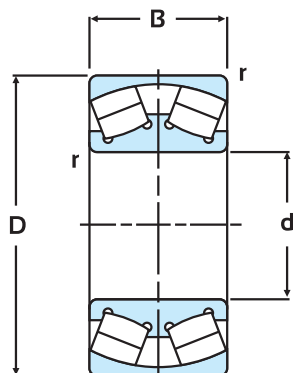

Cylindrical bore

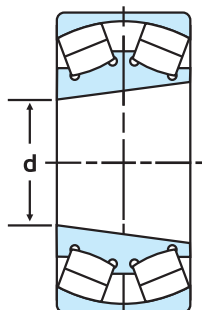

Tapered bore (K)
(1:12)

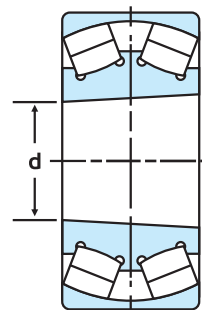

Tapered bore (K30)
(1:30)

Boundary Dimension (mm)				CONFIGURATION								Basic Load Rating (N)		Basic Load Rating (kgf)		Bearing Number	Mass Kg. (Approx.)
d	D	B	r	CA	CC	MB	K	K30	W33	W33X	Dynamic Cr	Static Cor	Dynamic Cr	Static Cor			
200	320	104	3.0			✓		✓			1190000	2020000	121305	205912	23138	35.100	
	340	120	4.0			✓	✓	✓			1450000	2350000	147808	239551	23238	48.100	
	320	128	3.0			✓		✓			1420000	2480000	144750	252803	24138	41.600	
	360	98	4.0			✓	✓	✓			1310000	2010000	133537	204893	22240	44.000	
	420	138	5.0			✓		✓			2040000	3050000	207951	310907	22340	94.500	
	340	112	3.0			✓	✓	✓			1355000	2280000	138124	232416	23140	42.500	
	360	128	4.0			✓	✓	✓			1620000	2640000	165138	269113	23240	57.900	
	280	60	2.1	✓			✓	✓	✓			550000	1100000	56065	112130	23940	12.000
	310	109	2.1				✓	✓	✓			1150000	2150000	117227	219164	24040	30.000
220	400	108	4.0			✓	✓	✓			1575000	2355000	160550	240061	22244	59.100	
	340	90	3.0			✓	✓	✓			1100000	1920000	112130	195719	23044	30.100	
	370	120	4.0			✓	✓	✓			1520000	2710000	154944	276249	23144	52.500	
	400	144	4.0	✓		✓	✓	✓		✓	2100000	3500000	214067	356779	23244	80.000	
	340	118	3.0			✓	✓	✓			1355000	2580000	138124	262997	24044	38.600	
240	440	120	4.0		✓	✓	✓	✓			1900000	3040000	193680	309888	22248	82.600	
	400	128	4.0			✓	✓	✓			1720000	3050000	175331	310907	23148	64.600	
	440	160	4.0			✓	✓	✓			2430000	4100000	247706	417941	23248	107.000	
	400	160	4.0	✓		✓	✓	✓			2000000	3850000	203874	392457	24148	79.000	
260	540	165	6.0		✓			✓			3200000	4750000	326198	484200	22352	181.000	
	400	104	4.0			✓	✓	✓			1420000	2620000	144750	267074	23052	47.200	
	440	144	4.0			✓	✓	✓			2120000	3830000	216106	390418	23152	92.000	
280	420	106	4.0	✓		✓	✓	✓			1510000	2920000	153925	297655	23056	52.400	
	460	146	5.0	✓		✓	✓	✓			2295000	4150000	233945	423038	23156	96.200	
	460	180	5.0		✓					✓	2730000	5200000	278287	530071	24156	121.000	
300	440	105	4.0								1450000	2760000	147808	281346	3760	55.000	
	460	118	4.0			✓	✓	✓			1890000	3550000	192661	361876	23060	72.500	
	500	160	5.0			✓	✓	✓			2720000	4690000	277268	478084	23160	127.000	
	540	192	5.0	✓				✓			3450000	6000000	351682	611621	23260	193.000	
	500	200	5.0		✓					✓	3300000	6400000	336391	652396	24160	159.000	
320	480	121	4.0	✓				✓			1940000	3790000	197757	386340	23064	80.100	
	580	208	5.0	✓		✓	✓	✓			4050000	7130000	412844	726809	23264	247.000	
	520	133	5.0			✓	✓	✓			2310000	4450000	235474	453619	23068	103.000	
340	620	224	6.0	✓			✓	✓			4650000	8100000	474006	825688	23268	297.000	
	460	90	3.0	✓			✓	✓			1200000	2700000	122324	275229	23968	44.500	
	580	243	5.0	✓				✓			5168000	8950000	526809	912334	24168	266.500	
	600	192	5.0	✓			✓	✓			3750000	7050000	382263	718654	23172	230.000	
360	480	90	3.0	✓				✓			1300000	2850000	132518	290520	23972	47.000	
	540	180	5.0	✓		✓		✓			3200000	6650000	326198	677880	24072	147.000	
380	560	135	5.0	✓				✓		2520000	5270000	256881	537207	23076	116.000		
400	590	142	5.0								2450000	5000000	249745	509684	3880	134.000	
	650	250	6.0	✓						✓	5950000	10390000	606524	1059123	24180	325.000	
420	620	150	5.0	✓						✓	3270000	6400000	333333	652396	23084	155.000	

● SPHERICAL ROLLER BEARING

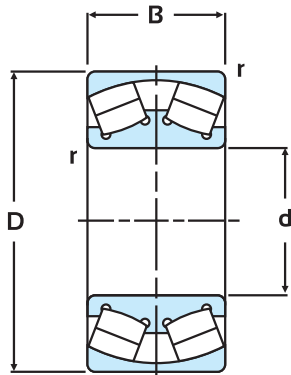

Cylindrical bore

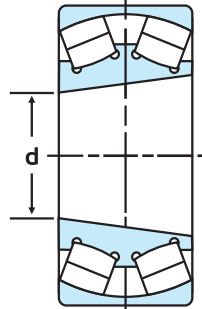

Tapered bore (K)
(1:12)

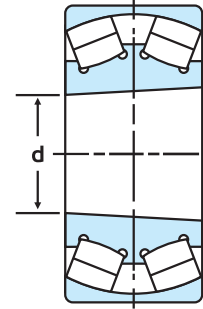

Tapered bore (K30)
(1:30)

Boundary Dimension (mm)				CONFIGURATION								Basic Load Rating (N)		Basic Load Rating (kgf)		Bearing Number	Mass Kg. (Approx.)
d	D	B	r	CA	CC	MB	K	K30	W33	W33X	Dynamic Cr	Static Cor	Dynamic Cr	Static Cor			
440	760	272	7.5			✓	✓	✓			6550000	12100000	667686	1233435	23284	526.000	
	720	280	6.0			✓		✓			6450000	13100000	657492	1335372	24188	473.000	
480	870	310	7.5	✓		✓		✓			8350000	15500000	851172	1580020	23296	808.000	
	790	308	7.5	✓						✓	8680000	15520000	884811	1582059	24196	605.000	
560	920	355	7.5	✓		✓		✓			10000000	20500000	1019368	2089704	241/560	941.000	
750	920	128	5.0	✓		✓		✓			3100000	8450000	316004	861366	238/750	188.000	
						✓		✓			3600000	11050000	366972	1126402	"40038/750 248/750)"	245.000	
	1420	620	12.0			✓	✓	✓			23300000	49260000	2375127	5021407	241/900	3480.000	
850	1220	365	7.5	✓				✓			12700000	31500000	1294597	3211009	"40031/850 (240/850)"	1410.000	
	1420	180	6.0	✓				✓			5620000	17200000	572885	1753313	238/1180	565.000	

● SPHERICAL ROLLER THRUST BEARING

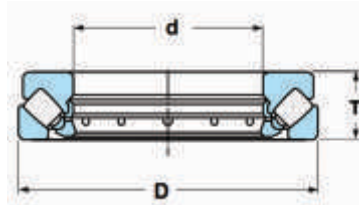

Boundary Dimension (mm)				CAGE CONFIGURATION					Basic Load Rating (N)		Basic Load Rating (kgf)		Bearing Number	Mass Kg. (Approx.)
d	D	B	r	J	M	MF	MB	MA	Dynamic Cr	Static Cor	Dynamic Cr	Static Cor		
60	130	42	1.5		✓				300000	950000	30581	96840	29412	2.900
70	150	48	2.0		✓				390000	1260000	39755	128440	29414	3.750
80	170	54	2.1		✓				490000	1600000	49949	163099	29416	5.810
90	190	60	2.1		✓				580000	1980000	59123	201835	29418	7.550
100	210	67	3.0		✓				715000	2420000	72885	246687	29420	11.000
110	230	73	3.0		✓				850000	2900000	86646	295617	29422	17.900
	190	48	2.0	✓					610000	1730000	62181	176351	29322	5.240
120	250	78	4.0		✓				1150000	3400000	117227	346585	29424	17.500
	210	54	2.1	✓					765000	2100000	77982	214067	29324	7.320
130	270	85	4.0	✓	✓				1510000	4020000	153925	409786	29426	22.100
	225	58	2.1	✓					753000	2500000	76758	254842	29326	8.860
140	240	60	2.1		✓				850000	2840000	86646	289501	29328	10.700
150	250	60	2.1	✓	✓				1020000	2900000	103976	295617	29330	11.500
170	340	103	5.0	✓					2360000	6550000	240571	667686	29434	40.500
	280	67	3.0		✓				1220000	3600000	124363	366972	29334	15.500
	380	115	5.0	✓					2500000	8300000	254842	846075	29438	56.000
190	380	230	5.0	✓				✓	2654000	8306000	270540	846687	29438D	112.000
	320	78	4.0		✓				1170000	4850000	119266	494393	29338	26.000
200	340	85	4.0	✓					1600000	5200000	163099	530071	29340	28.500
260	480	132	6.0	✓					4050000	12900000	412844	1314985	29452	96.000
300	480	109	5.0	✓	✓		✓		2700000	10850000	275229	1106014	29360	73.500
320	500	109	5.0		✓				3250000	10600000	331295	1080530	9039364	75.400
	500	109	5.0	✓			✓		3240000	11050000	330275	1126402	29364	73.000
380	520	85	5.0		✓				2000000	9550000	203874	973496	29276	53.500
	670	175	7.5		✓				6800000	24000000	693170	2446483	29476	245.000
400	710	185	7.5		✓				6650000	27000000	677880	2752294	29480	311.000
	710	185	7.5		✓				6650000	27000000	677880	2752294	29480	295.000
420	580	95	5.0		✓				1900000	9700000	193680	988787	29284	74.000
460	800	206	9.5		✓				7620000	30500000	776758	3109072	29492	420.000
500	870	224	9.5		✓				9320000	37100000	950051	3781855	294/500	540.000
560	980	250	12.0		✓				12400000	51500000	1264016	5249745	294/560	770.000
	980	250	12.0	✓					11900000	48600000	1213048	4954128	294/560	810.000
750	1280	315	15.0			✓	✓		18700000	85000000	1906218	8664628	294/750	1569.000
	1280	315	15.0		✓				15000000	76000000	529052	7747197	294/750	1650.000
800	1360	335	15.0			✓	✓		20000000	93000000	2038736	9480122	294/800	2025.000
850	1440	354	15.0			✓	✓		24000000	108000000	2446483	11009174	294/850	2390.000

● AAR STANDARD CARTRIDGE TAPERED ROLLER BEARINGS

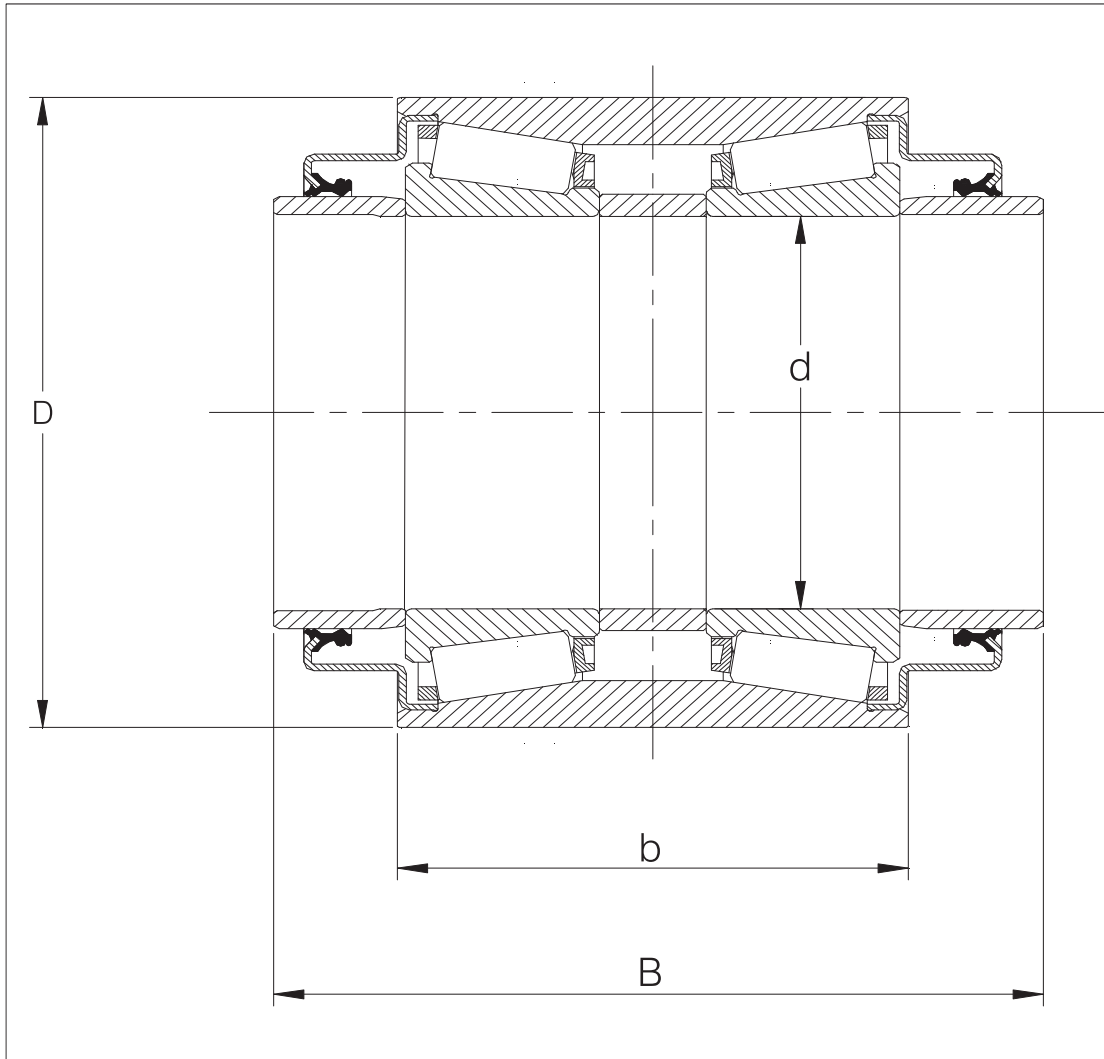

BOUNDARY DIMENSION (mm)				LOAD RATING (N)		
d	D	b	B	BEARING SIZE	DYNAMIC C	STATIC Co
119.063	195.263	142.9	217.1	CTRB 5x9 CLASS 'C' *	684000	109000
131.75	207.963	152.4	225.4	CTRB 5 1/2X10 CLASS 'D' *	724000	1232160
144.45	220.663	163.5	241.3	CTRB 6X11 CLASS 'E' **	774000	1347810
157.15	252.413	184.2	273.1	CTRB 6 1/2X12 CLASS 'F' ***	1052000	1825000
157.15	249.87	160	216.6	CTRB 6 1/2X9 CLASS 'K' ***	1052000	1825000

* AVAILABLE WITH STEEL CAGE ONLY

** AVAILABLE WITH BOTH STEEL & POLYAMIDE CAGE

*** AVAILABLE WITH POLYAMIDE CAGE ONLY

● METRIC CARTRIDGE TAPERED ROLLER BEARINGS

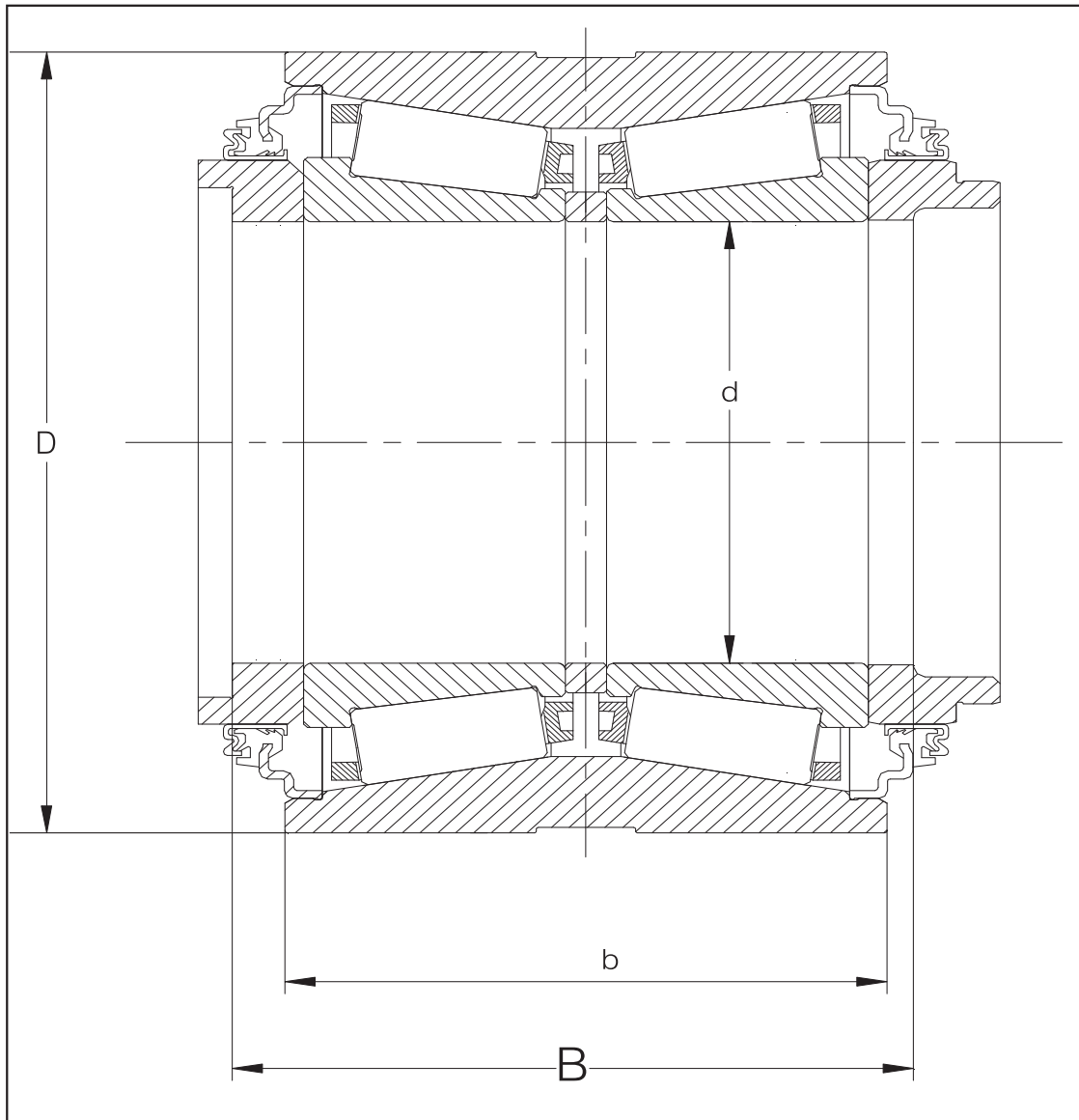

BOUNDARY DIMENSION (mm)				LOAD RATING (N)		
d	D	b	B	BEARING SIZE	DYNAMIC C	STATIC Co
130	230	160	177	UIC130X230	852000	1636000

NOTE:- AVAILABLE WITH POLYAMIDE CAGE ONLY

● UNITS SPECIFIED IN SI SYSTEM

Force

$$1 \text{ KN (Kilo newton)} = 1000\text{N} = 102\text{Kgf}$$

$$1 \text{ Kgf} = 9.81\text{N}$$

Pressure

$$1 \text{ bar} = 10 \text{ N/cm}^2 = 1.02 \text{ Kg/cm}^2$$

$$1 \text{ Kgf/mm}^2 = 9.81 \text{ N/cm}^2 = 0.981 \text{ bar}$$

Stress Contact Pressure

$$1 \text{ N/mm}^2 = 1 \text{ Mpa (Mega pascal)}$$

$$= 0.102 \text{ Kgf/mm}^2$$

$$1 \text{ Kgf/mm}^2 = 9.81 \text{ N/mm}^2$$

Torque

$$1 \text{ Nm} = 0.102 \text{ Kgf-m}$$

$$1 \text{ Kgf-m} = 9.81 \text{ Nm}$$

Energy

$$1 \text{ J (Joule)} = 1 \text{ Nm} = 1\text{Ws (Watt Second)}$$

$$= 0.102 \text{ Kgf-m}$$

$$1 \text{ Kgf-m} = 9.81 \text{ ws} = 9.81 \text{ Nm}$$

$$= 9.81 \text{ J}$$

Power

$$1 \text{ W} = 1\text{J/s} = 1 \text{ Nm/s} = 0.102 \text{ Kgf-m/s}$$

$$1 \text{ KW} = 1.36 \text{ PS} = 102 \text{ Kgf-m/s}$$

$$1 \text{ PS} = 0.736 \text{ KW} = 75 \text{ Kgf-m/s}$$

$$1 \text{ Kgf-m/s} = 9.81 \text{ N-m/s} = 9.81 \text{ J/s}$$

$$= 9.81 \text{ W}$$

Kinematic Viscosity

$$1\text{mm}^2/\text{s} = 1\text{cst (Centi stoke)}$$

● STEEL BALLS

INCH SIZE		METRIC SIZES	
Basic Diameter	Weight per 1000 balls in kg	Basic Diameter	Weight per 1000 balls in kg
7/64	0.08722	3	0.1102
1/8	0.1302	3.5	0.1769
5/32	0.2543	4	0.2630
3/16	0.4395	4.5	0.3707
7/32	0.6979	5	0.5086
15/64	0.8583	5.5	0.6804
1/4	1.042	6	0.8788
17/64	1.250	6.5	1.1295
9/32	1.483	7	1.4107
5/16	2.035	7.5	1.7418
11/32	2.708	8	2.1001
3/8	3.516	8.5	2.522
13/32	4.469	9	3.003
7/16	5.582	10	4.110
15/32	6.867	11	5.489
31/64	7.576	12	7.121
1/2	8.333	13	9.027
17/32	9.996	14	11.295
9/16	11.87	15	13.73
19/32	13.96	16	16.78
5/8	16.28	17	20.18
21/32	18.84	18	24.00
11/16	21.66	20	32.88
23/32	24.75	21	38.10
3/4	28.13	22	43.82
25/32	31.79	23	49.90
13/16	35.77	24	56.70
27/32	40.05	25	64.41
7/8	44.66		
29/32	49.62		
15/16	54.93		
31/32	60.61		
1	66.67		

CONVERSION TABLES.

INCHES TO MILLIMETERS. FRACTIONS.

Inches	mm		Inches	mm	
1/64	.015625	.03969	33/64	.515626	13.0969
1/32	.03125	.7937	17/32	.53125	13.4937
3/64	.046875	1.1906	35/64	.546875	13.8906
1/16	.0625	1.5875	9/16	.5625	14.2875
5/64	.78125	1.9844	37/64	.578125	14.6844
3/32	.09375	2.3812	19/32	.59375	15.0812
7/64	.109375	2.7781	39/64	.609375	15.4781
1/8	.125	3.1750	5/8	.625	15.8750
	.140625	3.5719	41/64	.640625	16.2719
5/32	.15825	3.9687	21/32	.65625	16.6637
11/64	.171875	4.3658	43/64	.671875	17.0656
3/16	.1875	4.7625	11/16	.6875	17.4625
13/64	.201325	5.1594	45/64	.703125	17.8594
7/32	.21875	5.5562	23/32	.71875	18.2562
15/64	.234375	5.9531	47/64	.734375	18.6531
1/4	.25	6.3500	3/4	.75	19.0500
17/64	.255625	6.7469	49/64	.765625	19.4469
9/32	.28125	7.1437	25/32	.78125	19.8437
19/64	.296875	7.5408	51/64	.796875	20.2406
5/16	.3125	7.9375	13/16	.8125	20.6375
21/64	.328125	8.3344	53/64	.828125	21.0344
11/32	.34375	8.7312	27/32	.84375	21.4312
23/64	.359375	9.1281	55/64	.859375	21.8281
3/8	.375	9.5250	7/8	.875	22.2250
25/64	.390625	9.9219	57/64	.890625	22.6219
13/32	.40625	10.3187	29/32	.90625	23.0187
27/64	.421875	10.7156	59/64	.921875	23.4156
7/16	.4375	11.1125	15/16	.9375	23.8125
29/64	.453125	11.5094	61/64	.953125	24.2094
15/32	.46875	11.9062	31/32	.96875	24.6062
31/64	.484375	12.3030	63/64	.984375	25.0031
1/2	.5	12.7000			

MILLIMETERS TO INCHES UNITS.

mm		10	20	30	40	50	60	70	80	90
0		.39370	.78740	1.18110	1.57480	1.96851	2.36221	2.75591	3.14961	3.54331
1	.03937	.43360	.82677	1.22047	1.61417	2.00788	2.40158	2.79528	3.18898	3.58288
2	.07874	.47244	.86614	1.25984	1.65354	2.044.95	2.83465	3.22835	3.22835	3.62205
3	.11811	.51181	.90551	1.29921	2.08662	2.08662	2.48034	2.87402	3.26772	3.66142
4	.15748	.55118	.94488	1.33858	1.73228	2.12599	2.15969	2.91339	3.30709	3.70079
5	.19685	.59055	.98425	1.37795	1.77165	2.16536	2.55906	2.95276	3.34646	3.74016
6	.23622	.62992	1.02362	1.41732	1.81103	2.20473	2.59843	2.99213	3.38583	3.77953
7	.27559	.66929	1.06299	1.45669	1.85040	2.24410	2.63780	3.03150	3.42520	3.81890
8	.31496	.70866	1.10236	1.49606	1.88977	2.28347	2.67717	3.07087	3.46457	3.85827
9	.35433	.74803	1.14173	1.53543	1.92914	2.32284	2.71654	3.11024	3.50395	3.89764

CONVERSION TABLES.

MILLIMETERS TO INCHES UNITS.

mm		100	200	300	400	500	600	700	800	900
0		3.93701	7.87402	11.8110	15.7480	19.6851	23.6221	27.5591	31.4961	35.4331
10	.39370	4.33071	8.26772	12.2047	16.1417	20.0788	24.0158	27.9528	31.8898	35.8268
20	.78740	4.72441	8.66142	12.5984	16.5354	20.4725	24.4095	28.3465	32.2835	36.2205
30	1.18110	5.11811	9.05513	16.9921	16.9291	20.8662	24.8032	28.7402	32.6772	36.6142
40	1.57480	5.51181	9.44883	13.3858	17.3228	21.2599	25.1969	29.1339	33.0709	37.0079
50	1.96851	5.90552	9.84252	13.7795	17.7165	21.6536	25.5906	29.5276	33.4646	37.4016
60	2.36221	6.29922	10.2362	14.1732	18.1103	22.0473	25.9843	29.9213	33.8583	37.7953
70	2.75591	6.69292	10.6299	14.5669	18.5040	22.4410	26.3780	30.3150	34.2520	38.1890
80	3.14961	7.08662	11.0236	14.9606	18.8977	22.8347	26.7717	30.7087	34.6457	38.5827
90	3.54331	7.48032	11.4173	15.3543	19.2914	23.2284	27.1654	31.1024	35.0394	38.9764

FRACTIONS

mm	Inch	mm	Inch	mm	Inch
0.001	.000039	0.01	.00039	0.1	.0039
0.002	.000079	0.02	.00079	0.2	.0079
0.003	.000118	0.03	.00118	0.3	.0118
0.004	.000157	0.04	.00157	0.4	.0157
0.005	.000197	0.05	.00197	0.5	.0197
0.006	.000236	0.06	.00236	0.6	.0236
0.007	.000276	0.07	.00276	0.7	.0276
0.008	.000315	0.08	.00315	0.8	.0315
0.009	.000354	0.09	.00354	0.9	.0354

Inch	mm	Inch	mm	Inch	mm
0.001	.0254	0.01	0.254	0.1	2.54
0.002	.0508	0.02	0.508	0.2	5.08
0.003	.0762	0.03	0.762	0.3	7.62
0.004	.1016	0.04	1.016	0.4	10.16
0.005	.1270	0.05	1.270	0.5	12.70
0.006	.1524	0.06	1.524	0.6	15.24
0.007	.1778	0.07	1.778	0.7	17.78
0.008	.2032	0.08	2.032	0.8	20.32
0.009	.2286	0.09	2.286	0.9	22.86

Inch	mm		
	10	20	30
0	254.0	508.0	762.0
1	25.4	279.4	533.4
2	50.8	304.8	558.8
3	76.2	330.2	584.2
4	101.6	355.6	609.6
5	127.0	381.0	635.0
6	152.4	406.4	660.4
7	177.8	431.8	685.8
8	203.2	457.2	711.2
9	228.6	482.6	736.6

Hardness conversion table (reference)

Rockwell hardness C scale 1471.ON (150kgf)	Vicker's hardness	BRINELL HARDNESS		ROCKWELL HARDNESS		Shore hardness
		Standard steel ball	Tungsten carbide steel ball	A scale 588.4N (60kgf)	B scale 980.7N (100kgf)	
68	940			85.6		97
67	900			85.0		95
66	865			84.5		92
65	832		739	83.9		91
64	800		722	83.4		88
63	772		705	82.8		87
62	746		688	82.3		85
61	720		670	81.8		83
60	697		654	81.2		81
59	674		634	80.7		80
58	653		615	80.1		78
57	633		595	79.6		76
56	613		577	79.0		75
55	595	-	560	78.5		74
54	577	-	543	78.0		72
53	560	-	525	77.4		71
52	544	500	512	76.8		69
51	528	487	496	76.3		68
50	513	475	481	75.9		67
49	498	464	469	75.2		66
48	484	451	455	74.7		64
47	471	442	443	74.1		63
46	458	432	432	73.6		62
45	446	421	421	73.1		60
44	434	409	409	72.5		58
43	423	400	400	72.0		57
42	412	390	390	71.5		56
41	402	381	381	70.9		55
40	392	371	371	70.4	-	54
39	382	362	362	69.9	-	52
38	372	353	353	69.4	-	51
37	363	344	344	68.9	-	50
36	354	336	336	68.4	(109.0)	49
35	345	327	327	67.9	(108.5)	48
34	336	319	319	67.4	(108.0)	47
33	327	311	311	66.8	(107.5)	46
32	318	301	301	66.3	(107.0)	44
31	310	294	294	65.8	(106.0)	43
30	302	286	286	65.3	(105.5)	42
29	294	279	279	64.7	(104.5)	41
28	286	271	271	64.3	(104.0)	41
27	279	264	264	63.8	(103.0)	40
26	272	258	258	63.3	(102.5)	38
25	266	253	253	62.8	(101.5)	38
24	260	247	247	62.4	(101.0)	37
23	254	243	243	62.0	100.0	36
22	248	237	237	61.5	99.0	35
21	243	231	231	61.0	98.5	35
20	238	226	226	60.5	97.8	34
(18)	230	219	219	-	96.7	33
(16)	222	212	212	-	95.5	32
(14)	213	203	203	-	93.9	31
(12)	204	194	194	-	92.3	29
(10)	196	187	187		90.7	28
(8)	188	179	179		89.5	27
(6)	180	171	171		87.1	26
(4)	173	165	165		85.5	25
(2)	166	158	158		83.5	24
(0)	160	152	152		81.7	24

1 Meter = 39.370113 inches
1 Inch = 25.399978 millimeters

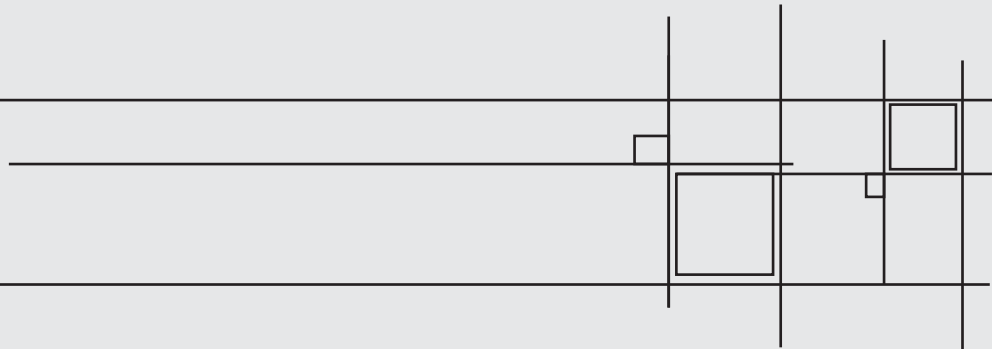

National Engineering Industries Ltd., part of the 150 year old, multi-billion dollar C.K. Birla group manufactures a wide range of Ball & Roller bearings for automotive and railway industry as well as for general industrial applications under the brand name nbc. NEI also manufactures Steel Balls and Axle Boxes, produced at plants located at Jaipur, Newai & Manesar.



NEI, founded in the year 1946 as a pioneer industry in the field of bearing, manufacturing over 1450 different sizes ranging from 6 mm bore to 1300 mm outer diameter and having capability to manufacture bearing upto 2000 mm. diameter.



Bearings are manufactured for every possible application and requirement of modern engineering industry and we continue to develop new sizes, keeping pace with rapid advancement in the Indian & Global engineering industry. NEI's technical collaborations with world's leading conglomerate in the field of bearing technology viz. M/s NTN Corporation of Japan, and M/s AMSTED Rail, USA have given a whole new dimension to the product range and a quality par excellence.



NEI has implemented modern concepts of Total Quality Management (TQM) and being awarded that coveted Deming Application Prize in 2010 and Deming Grand Prize in 2015, NEI is the only bearing company in India to receive these prestigious awards, NEI is also accredited with QS 9000 and TS 16949 certifications.



NEI has also been awarded Association of American Railroads (AAR) for AAR certificate M-1003 for Cartridge Tapered Roller Bearing in February 2005. NEI has been awarded ISO-14001 certificate for its concern & commitment towards a cleaner environment. We at NEI are confident that all users of NEI products will find a new presentation of this technical catalogue useful and informative and you are welcome to consult, NEI for every assistance in selecting right bearing for any application that you have in mind.



This edition of the NBC Catalogue contains all necessary information and data required for selection of right bearing for specific applications. The data is based on International Standards laid down for the purpose and our manufacturing experience of more than 60 years.

Our catalogue has been revised as per the latest IS/ISO standards for chamfer, dimensions, bearing accuracies, quality symbols and definitions and new sizes being added. For improvement as well as other reasons, the contents of this catalogue are subject to change without prior notice.



NBC bearings are exported to the following countries:

USA | GERMANY | JAPAN | ITALY | SINGAPORE | ARGENTINA
GUATEMALA | BRAZIL | GUYANA | SAUDI ARABIA | PAKISTAN | CHINA
KENYA | AUSTRALIA | PERU | UAE | SRI LANKA | BANGLADESH | NIGERIA
MALAYSIA | NEPAL | BHUTAN | TURKEY | CANADA | COLUMBIA | MEXICO

Branch Office

Mumbai Mumbai

C-216, 2nd Floor, 215 Atrium,
Sir Mathurabas Vassanji Road,
Chakala, Andheri (East), Mumbai - 400059
Ph.: +91-22-67582200
E-mail: neimum@nbcbearings.in

Mehta Building 26, Calicut Street,
Ballar Estate, Mumbai - 400038
Ph.: +91-22-22671790
E-mail: neimum@nbcbearings.in

New Delhi Pune

3rd Floor, Guru Angad Bhawan,
71, Nehru Place, New Delhi - 110019
Ph.: +91-11-26417629, 26430209
E-mail: neidli@nbcbearings.in

210, Century Arcade, 243-244 B,
Narangi Baug Road, Pune - 411001
Ph.: +91-20-26162145
E-mail: neipune@nbcbearings.in

Kolkata Chennai

11th Floor-Birla Building,
9/1, R.N.Mukherjee Road, Kolkata - 700001
Ph.: +91-33-22420910, 22482109
E-mail: neical@nbcbearings.in

7A, 2nd Floor, Wellington Estate,
53 Ethiraj Salai, Chennai - 600008
Ph.: +91-44-28270289, 28205412, 28255696
E-mail: neichn@nbcbearings.in



flexible solutions

National Engineering Industries Ltd.

Khatipura Road, Jaipur, Rajasthan, INDIA - 302006 **Phone:** +91-141-2223221, **Fax:** +91-141-2222259, 22219226
Toll Free: 180030006222. **E-mail:** neisales@nbcbearings.in

www.nbcbearings.com

Follow us on:



/nbcbearings